

## Description

The XBLW MCP6001(single), XBLW MCP6002(dual) and XBLW MCP6004(quad) are general purpose, low offset, high frequency response and micro power operational amplifiers. With an excellent bandwidth of 1MHz, a slew rate of  $0.8V/\mu s$ , and a quiescent current of  $80\mu A$  per amplifier at 5V, the XBLW MCP6001/6002/6004 family can be designed into a wide range of applications.

The XBLW MCP6001/6002/6004 op-amps are designed to provide optimal performance in low voltage and low power systems. The input common-mode voltage range includes ground, and the maximum input offset voltage are  $4.5mV$ . These parts provide rail-to-rail output swing into heavy loads. The XBLW MCP6001/6002/6004 family is specified for single or dual power supplies of  $+1.8V$  to  $+6.0V$ .

The XBLW MCP6001 is available in 5-lead SOT-23 and SC70-5 package. The XBLW MCP6002 is available in 8-lead SOP-8 and MSOP-8 package. The XBLW MCP6004 is available in 14-lead SOP and TSSOP package.

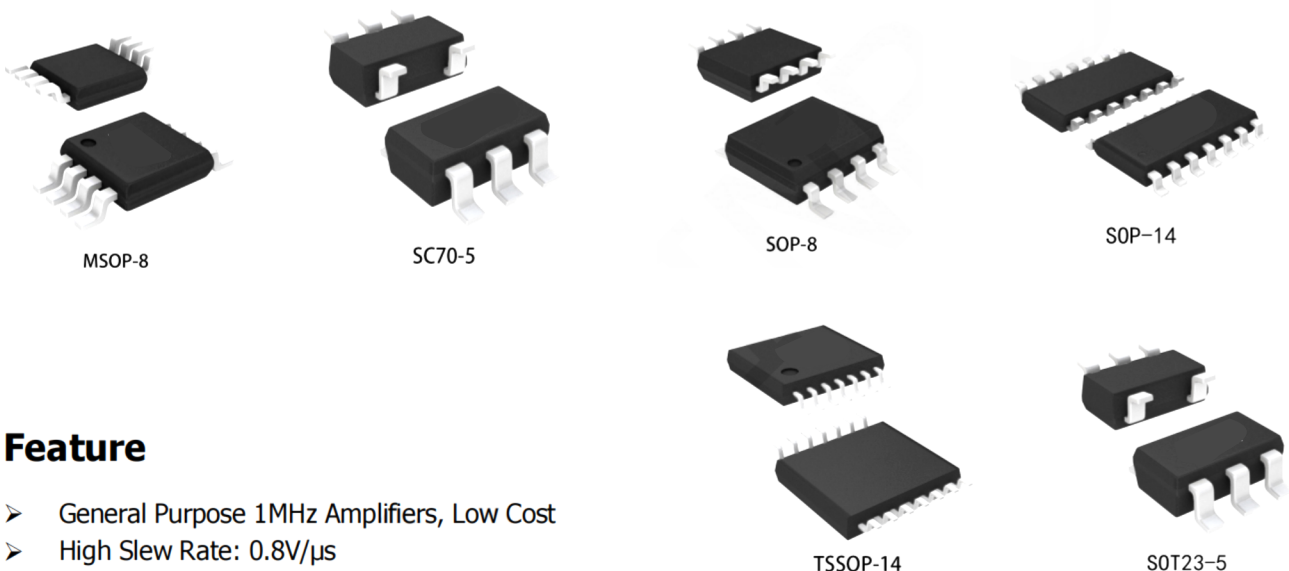

## Feature

- General Purpose 1MHz Amplifiers, Low Cost
- High Slew Rate:  $0.8V/\mu s$
- Low Offset Voltage:  $4.5 mV$  Maximum
- Low Power:  $80\mu A$  per Amplifier Supply Current
- Settling Time to 0.1% with 2V Step:  $4.2 \mu s$
- Unit Gain Stable
- Rail-to-Rail Input and Output
- Input Voltage Range:  $-0.1V$  to  $+5.1V$  at 5V Supply
- Operating Power Supply:  $+1.8V$  to  $+6V$
- Operating Temperature Range:  $-40^{\circ}C$  to  $+125^{\circ}C$
- ESD Rating: HBM-4kV, CDM-2kV

## Applications

- Active Filters
- Audio Outputs
- Sensor Interfaces
- Medical Instrumentation
- Battery-Powered Instrumentation
- Smoke/Gas/Environment Sensors
- Battery and Power Supply Control
- Portable Equipment and Mobile Devices

### Ordering Information

Product Model	Package Type	Marking	Packing	Packing Qty
XBLW MCP6001T-I/LT	SC70-5	6001CI	Tape	3000Pcs/Reel
XBLW MCP6001T-I/OT	SOT23-5	6001TI	Tape	3000Pcs/Reel
XBLW MCP6001RT-I/OT	SOT23-5	6001RI	Tape	3000Pcs/Reel
XBLW MCP6001UT-I/OT	SOT23-5	6001UI	Tape	3000Pcs/Reel
XBLW MCP6002T-I/SN	SOP-8	6002I	Tape	3000Pcs/Reel
XBLW MCP6002T-I/MS	MSOP-8	6002MI	Tape	3000Pcs/Reel
XBLW MCP6004T-I/SL	SOP-14	6004I	Tape	3000Pcs/Reel
XBLW MCP6004T-I/ST	TSSOP-14	6004TI	Tape	3000Pcs/Reel
XBLW MCP6001T-E/LT	SC70-5	6001CE	Tape	3000Pcs/Reel
XBLW MCP6001T-E/OT	SOT23-5	6001TE	Tape	3000Pcs/Reel
XBLW MCP6001RT-E/OT	SOT23-5	6001RE	Tape	3000Pcs/Reel
XBLW MCP6001UT-E/OT	SOT23-5	6001UE	Tape	3000Pcs/Reel
XBLW MCP6002T-E/SN	SOP-8	6002E	Tape	3000Pcs/Reel
XBLW MCP6002T-E/MS	MSOP-8	6002ME	Tape	3000Pcs/Reel
XBLW MCP6004T-E/SL	SOP-14	6004E	Tape	3000Pcs/Reel
XBLW MCP6004T-E/ST	TSSOP-14	6004TE	Tape	3000Pcs/Reel

Temperature Range: I = -40°C to + 85°C  
 E = -40°C to +125°C

### Pin Configurations

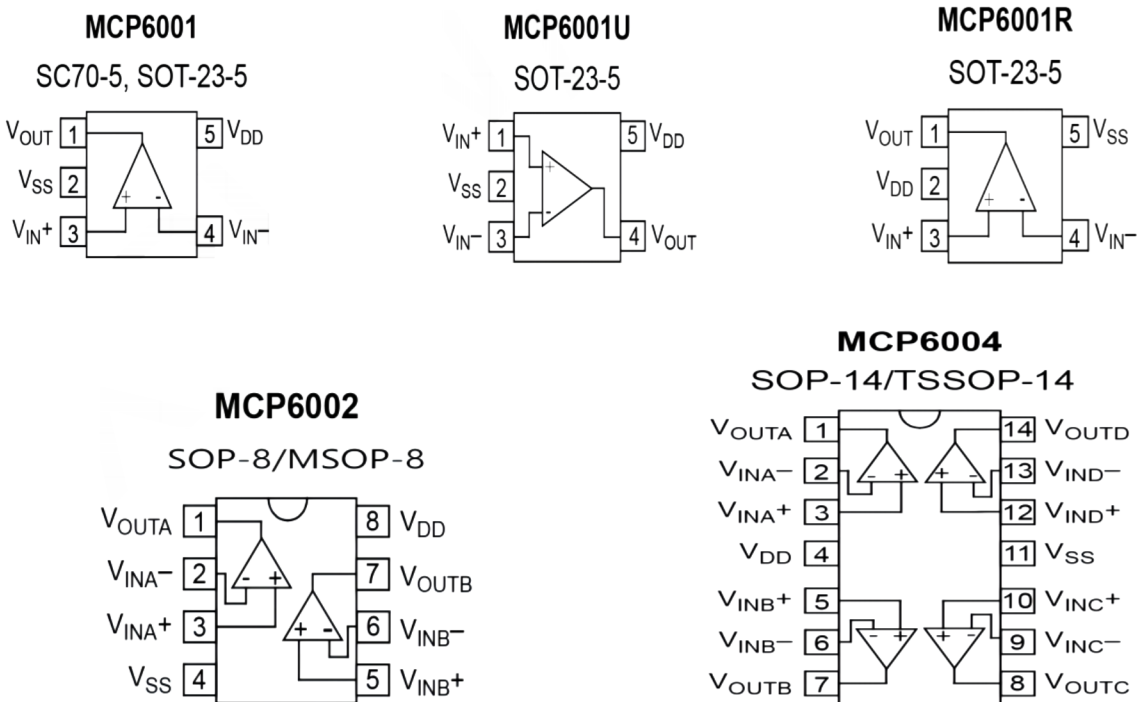

Figure 1 Pin Configurations

## Pin Description

Symbol	Description
V <sub>IN-</sub>	Negative (inverting) input.
V <sub>IN+</sub>	Positive (noninverting) input.
V <sub>INA-</sub> , V <sub>INB-</sub> V <sub>INC-</sub> , V <sub>IND-</sub>	Inverting Input of the Amplifier. The Voltage range can go from (V <sub>S-</sub> – 0.1V) to (V <sub>S+</sub> + 0.1V).
V <sub>INA+</sub> , V <sub>INB+</sub> V <sub>INC+</sub> , V <sub>IND+</sub>	Non-Inverting Input of Amplifier. This pin has the same voltage range as -IN.
V <sub>DD</sub>	Positive Power Supply. The voltage is from 1.8V to 6.0V. Split supplies are possible as long as the voltage between V <sub>S+</sub> and V <sub>S-</sub> is between 1.8V and 6.0V. A bypass capacitor of 0.1μF as close to the part as possible should be used between power supply pins or between supply pins and ground
V <sub>SS</sub>	Negative Power Supply. It is normally tied to ground. It can also be tied to a voltage other than ground as long as the voltage between V <sub>S+</sub> and V <sub>S-</sub> is from 1.8V to 6.0V. If it is not connected to ground, bypass it with a capacitor of 0.1μF as close to the part as possible.
V <sub>OUT</sub>	Output.
V <sub>OUTA</sub> , V <sub>OUTB</sub> V <sub>OUTC</sub> , V <sub>OUTD</sub>	Amplifier Output

## Absolute Maximum Ratings (TA= 25°C)

Symbol	Description	Value	Units
V <sub>S+</sub> , V <sub>S-</sub>	Supply Voltage, V <sub>S+</sub> to V <sub>S-</sub>	7.0	V
V <sub>CM</sub>	Common-Mode Input Voltage	V <sub>S-</sub> – 0.3 to V <sub>S+</sub> + 0.3	V
ESD	Electrostatic Discharge Voltage	HBM ±4000	V
		CDM ±2000	V
T <sub>J</sub>	Junction Temperature	160	°C
T <sub>STG</sub>	Storage Temperature Range	-65 to +150	°C(T <sub>J</sub> )
T <sub>JL</sub>	Lead Temperature Range (Soldering 10sec)	260	°C

### Notes:

- Stresses beyond those listed under Absolute Maximum Ratings may cause permanent damage to the device. These are stress ratings only, which do not imply functional operation of the device at these or any other conditions beyond those indicated under Recommended Operating Conditions. Exposure to absolute-maximum-rated conditions for extended periods may affect device reliability.
- Provided device does not exceed maximum junction temperature (T<sub>J</sub>) at any time.

## Electrical Characteristics

$V_S = 5.0V$ ,  $T_A = +25^\circ C$ ,  $V_{CM} = V_S/2$ ,  $V_O = V_S/2$ , and  $R_L = 10k\Omega$  connected to  $V_S/2$ , unless otherwise noted.

Symbol	Parameter	Conditions	Min.	Typ.	Max.	Unit
INPUT CHARACTERISTICS						
$V_{OS}$	Input offset voltage		-4.5	$\pm 1.0$	+4.5	mV
	Over temperature		-4.8		+4.8	
$V_{OS\ TC}$	Offset voltage drift	Over Temperature		2.3		$\mu V/^\circ C$
$I_B$	Input bias current			1		pA
	Over temperature			500		
$I_{OS}$	Input offset current			1		pA
$V_{CM}$	Common-mode voltage range		$V_S - 0.1$		$V_S + 0.1$	V
CMRR	Common-mode rejection ratio	$V_{CM} = 0.05V$ to $3.5V$		90		dB
	Over temperature			85		
		$V_{CM} = V_S - 0.1$ to $V_S + 0.1 V$		80		
	Over temperature			75		
$A_{VOL}$	Open-loop voltage gain	$V_O = 0.05$ to $3.5 V$		110		dB
	Over temperature			100		
$R_{IN}$	Input resistance		100			G $\Omega$
$C_{IN}$	Input capacitance	Differential		2.0		pF
		Common mode		3.5		
OUTPUT CHARACTERISTICS						
$V_{OH}$	High output voltage swing			$V_S - 8$		mV
$V_{OL}$	Low output voltage swing			8		mV
$Z_{OUT}$	Closed-loop output impedance	$f = 200kHz$ , $G = +1$		0.4		$\Omega$
	Open-loop output impedance	$f = 1MHz$ , $I_o = 0$		2.6		
$I_{SC}$	Short-circuit current	Source current through $10\Omega$		40		mA
		Sink current through $10\Omega$		40		
DYNAMIC PERFORMANCE						
GBW	Gain bandwidth product	$f = 1kHz$		1.0		MHz
$\Phi_M$	Phase margin	$C_L = 100pF$		62		$^\circ$
SR	Slew rate	$G = +1$ , $C_L = 100pF$ , $V_O = 1.5V$ to $3.5V$		0.8		V/ $\mu s$

## Electrical Characteristics

$V_S = 5.0V$ ,  $T_A = +25^\circ C$ ,  $V_{CM} = V_S/2$ ,  $V_O = V_S/2$ , and  $R_L = 10k\Omega$  connected to  $V_S/2$ , unless otherwise noted.

Symbol	Parameter	Conditions	Min.	Typ.	Max.	Unit
$t_s$	Settling time	To 0.1%, $G = +1$ , 2V step		4.2		$\mu s$
		To 0.01%, $G = +1$ , 2V step		5.2		
$t_{OR}$	Overload recovery time	$V_{IN} * Gain > V_S$		2		$\mu s$
THD+N	Total harmonic distortion+Noise	$f = 1kHz$ , $G = +1$ , $V_O = 3V_{PP}$		0.003		%
NOISE PERFORMANCE						
$V_n$	Input voltage noise	$f = 0.1$ to 10 Hz		13		$\mu V_{P-P}$
$e_n$	Input voltage noise density	$f = 1kHz$		35		$nV/\sqrt{Hz}$
$I_n$	Input current noise density	$f = 10kHz$		6		$fA/\sqrt{Hz}$
POWER SUPPLY						
$V_S$	Operating supply voltage		1.8		6.0	V
PSRR	Power supply rejection ratio	$V_S = 1.8V$ to $6.0V$ , $V_{CM} < V_{S+} - 2V$		98		dB
	Over temperature			85		
$I_Q$	Quiescent current (peramplifier)			80	120	$\mu A$
	Over temperature			85	130	
THERMAL CHARACTERISTICS						
$T_A$	Operating temperature range		-40		+125	$^\circ C$
$\theta_{JA}$	Package thermal resistance	SOT23-5		190		$^\circ C/W$
		SOP-8/MSOP-8		125		
		SOP-14/TSSOP-14		115		

Specifications subject to changes without notice

## Typical Performance Characteristics

At  $T_A = +25^\circ\text{C}$ ,  $V_{CM} = V_S/2$ , and  $R_L = 10\text{k}\Omega$  connected to  $V_S/2$ , unless otherwise noted.

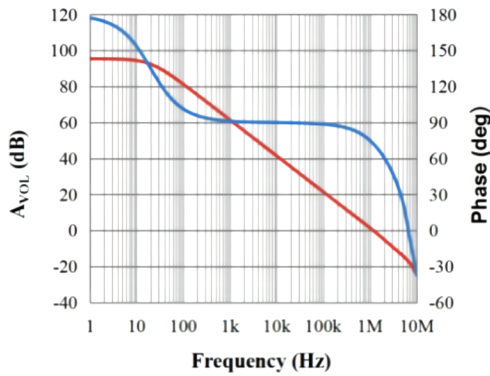

Figure 2 Open-loop Gain and Phase as function of Frequency

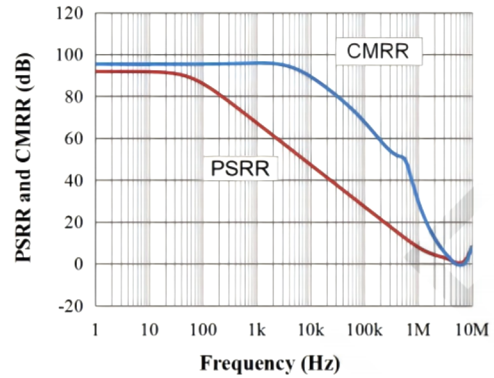

Figure 3 Power Supply and Common-mode Rejection Ratio as a function of Frequency

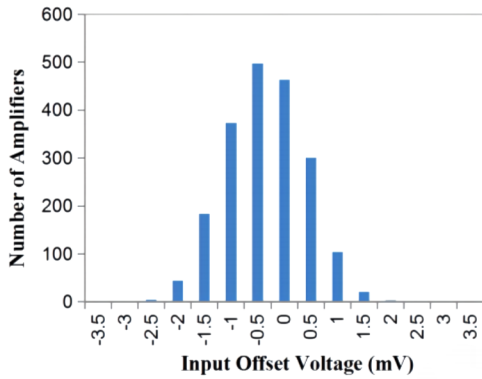

Figure 4 Input Offset Voltage Production Distribution

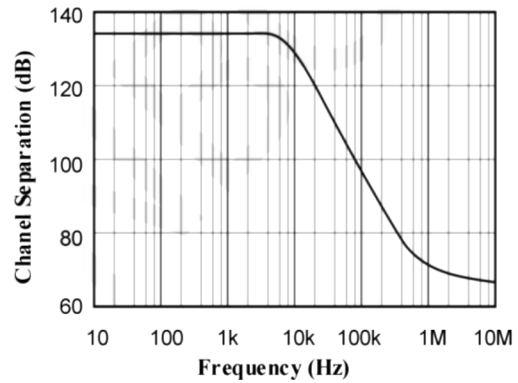

Figure 5 Channel Separation as a function of Frequency

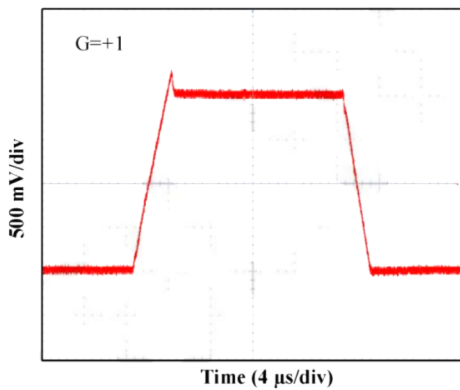

Figure 6 Large-Signal Step Response at 2.7V

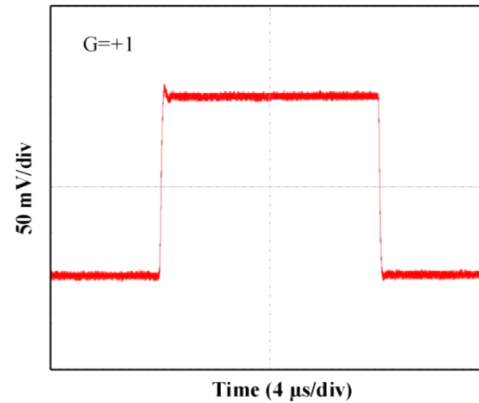

Figure 7 Small-Signal Step Response at 2.7V

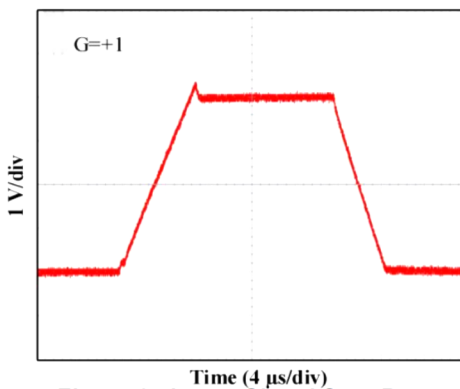

Figure 8 Large-Signal Step Response at 5V

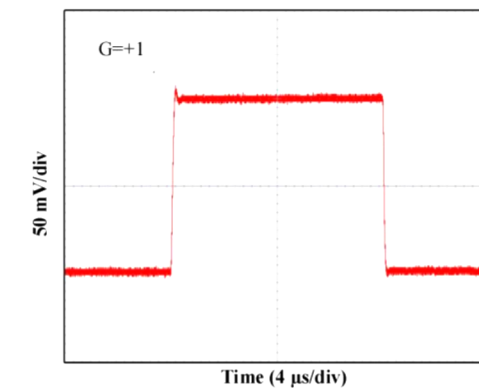

Figure 9 Small-Signal Step Response at 5V

## Application Notes

### 1. LOW INPUT BIAS CURRENT

The XBLW MCP6001/6002/6004 family is a CMOS op-amp family and features very low input bias current in pA range. The low input bias current allows the amplifiers to be used in applications with high resistance sources. Care must be taken to minimize PCB Surface Leakage. See below section on “PCB Surface Leakage” for more details.

### 2. PCB SURFACE LEAKAGE

In applications where low input bias current is critical, Printed Circuit Board (PCB) surface leakage effects need to be considered. Surface leakage is caused by humidity, dust or other contamination on the board. Under low humidity conditions, a typical resistance between nearby traces is  $10^{12}\Omega$ . A 5V difference would cause 5pA of current to flow, which is greater than the XBLW MCP6001/6002/6004’s input bias current at +25°C ( $\pm 1$ fA, typical). It is recommended to use multi-layer PCB layout and route the op-amp’s -IN and +IN signal under the PCB surface.

The effective way to reduce surface leakage is to use a guard ring around sensitive pins (or traces). The guard ring is biased at the same voltage as the sensitive pin. An example of this type of layout is shown in Figure 10 for Inverting Gain application.

1. For Non-Inverting Gain and Unity-Gain Buffer:

- a) Connect the non-inverting pin (+IN) to the input with a wire that does not touch the PCB surface.
- b) Connect the guard ring to the inverting input pin (-IN). This biases the guard ring to the Common Mode input voltage.

2. For Inverting Gain and Trans-impedance Gain Amplifiers (convert current to voltage, such as photo detectors):

- a) Connect the guard ring to the non-inverting input pin (+IN). This biases the guard ring to the same reference voltage as the op-amp (e.g.,  $V_S/2$  or ground).
- b) Connect the inverting pin (-IN) to the input with a wire that does not touch the PCB surface.

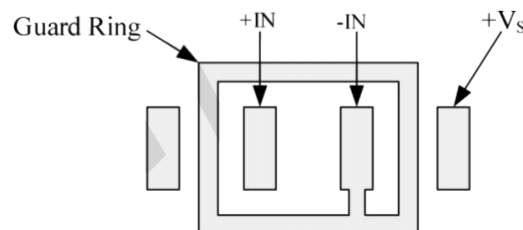

### 3. GROUND SENSING AND RAIL TO RAIL

The input common-mode voltage range of the XBLW MCP6001/6002/6004 series extends 100mV beyond the supply rails. This is achieved with a complementary input stage—an N-channel input differential pair in parallel with a P-channel differential pair. For normal operation, inputs should be limited to this range. The absolute maximum input voltage is 300mV beyond the supplies. Inputs greater than the input common-mode range but less than the maximum input voltage, while not valid, will not cause any damage to the op-amp. Unlike some other op-amps, if input current is limited, the inputs may go beyond the supplies without phase inversion, as shown in Figure 11. Since the input common-mode range extends from  $(V_{S-} - 0.1V)$  to  $(V_{S+} + 0.1V)$ , the XBLW MCP6001/6002/6004 op-amps can easily perform ‘true ground’ sensing.

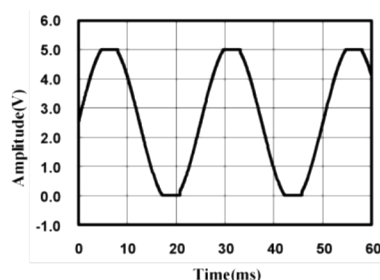

Figure 11 No Phase Inversion with Inputs Greater Than the Power-Supply Voltage

A topology of class AB output stage with common-source transistors is used to achieve rail-to-rail output. For light resistive loads (e.g.  $100\text{k}\Omega$ ), the output voltage can typically swing to within  $5\text{mV}$  from the supply rails. With moderate resistive loads (e.g.  $10\text{k}\Omega$ ), the output can typically swing to within  $10\text{mV}$  from the supply rails and maintain high open-loop gain.

The maximum output current is a function of total supply voltage. As the supply voltage to the amplifier increases, the output current capability also increases. Attention must be paid to keep the junction temperature of the IC below  $150^\circ\text{C}$  when the output is in continuous short-circuit. The output of the amplifier has reverse-biased ESD diodes connected to each supply. The output should not be forced more than  $0.5\text{V}$  beyond either supply, otherwise current will flow through these diodes.

#### 4. CAPACITIVE LOAD AND STABILITY

The XBLW MCP6001/6002/6004 can directly drive  $1\text{nF}$  in unity-gain without oscillation. The unity-gain follower (buffer) is the most sensitive configuration to capacitive loading. Direct capacitive loading reduces the phase margin of amplifiers and this results in ringing or even oscillation. Applications that require greater capacitive drive capability should use an isolation resistor between the output and the capacitive load like the circuit in Figure 12. The isolation resistor  $R_{\text{ISO}}$  and the load capacitor  $C_{\text{L}}$  form a zero to increase stability. The bigger the  $R_{\text{ISO}}$  resistor value, the more stable  $V_{\text{OUT}}$  will be. Note that this method results in a loss of gain accuracy because  $R_{\text{ISO}}$  forms a voltage divider with the  $R_{\text{L}}$ .

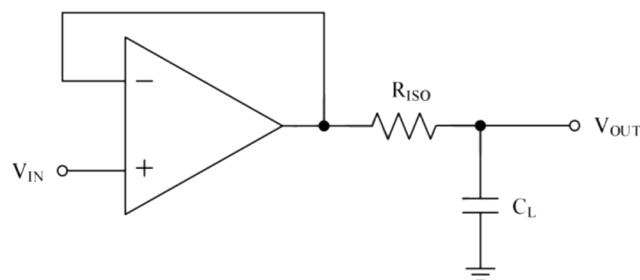

**Figure 12 Indirectly Driving Heavy Capacitive Load**

An improvement circuit is shown in Figure 13. It provides DC accuracy as well as AC stability. The  $R_{\text{F}}$  provides the DC accuracy by connecting the inverting signal with the output. The  $C_{\text{F}}$  and  $R_{\text{ISO}}$  serve to counteract the loss of phase margin by feeding the high frequency component of the output signal back to the amplifier's inverting input, thereby preserving phase margin in the overall feedback loop.

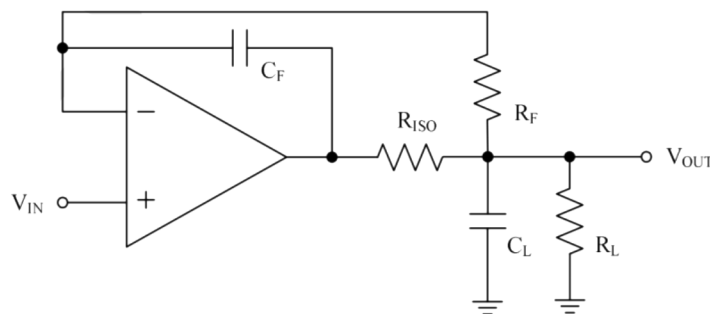

**Figure 13 Indirectly Driving Heavy Capacitive Load with DC Accuracy**

For no-buffer configuration, there are two other ways to increase the phase margin: (a) by increasing the amplifier's gain, or (b) by placing a capacitor in parallel with the feedback resistor to counteract the parasitic capacitance associated with inverting node.

#### 5. POWER SUPPLY LAYOUT AND BYPASS

The XBLW MCP6001/6002/6004 family operates from either a single  $+1.8\text{V}$  to  $+6.0\text{V}$  supply or dual  $\pm 0.9\text{V}$  to  $\pm 3.0\text{V}$  supplies. For single-supply operation, bypass the power supply  $V_{\text{S}}$  with a ceramic capacitor (i.e.  $0.01\mu\text{F}$  to  $0.1\mu\text{F}$ ) which should be placed close (within  $2\text{mm}$  for good high frequency performance) to the  $V_{\text{S}}$  pin. For dual-supply

operation, both the  $V_{S+}$  and the  $V_{S-}$  supplies should be bypassed to ground with separate 0.1 $\mu$ F ceramic capacitors. A bulk capacitor (i.e. 2.2 $\mu$ F or larger tantalum capacitor) within 100 mm to provide large, slow currents and better performance. This bulk capacitor can be shared with other analog parts.

Good PC board layout techniques optimize performance by decreasing the amount of stray capacitance at the op-amp's inputs and output. To decrease stray capacitance, minimize trace lengths and widths by placing external components as close to the device as possible. Use surface-mount components whenever possible. For the op-amp, soldering the part to the board directly is strongly recommended. Try to keep the high frequency big current loop area small to minimize the EMI (electromagnetic interfacing).

## 6. GROUNDING

A ground plane layer is important for the XBLW MCP6001/6002/6004 circuit design. The length of the current path speed currents in an inductive ground return will create an unwanted voltage noise. Broad ground plane areas will reduce the parasitic inductance.

## 7. INPUT-TO-OUTPUT COUPLING

To minimize capacitive coupling, the input and output signal traces should not be parallel. This helps reduce unwanted positive feedback.

# Typical Application Circuits

## 1. DIFFERENTIAL AMPLIFIER

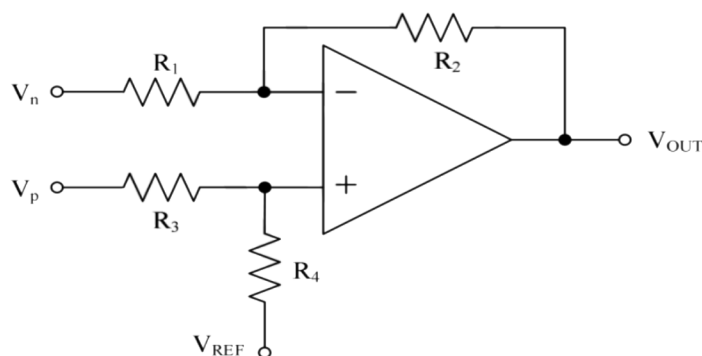
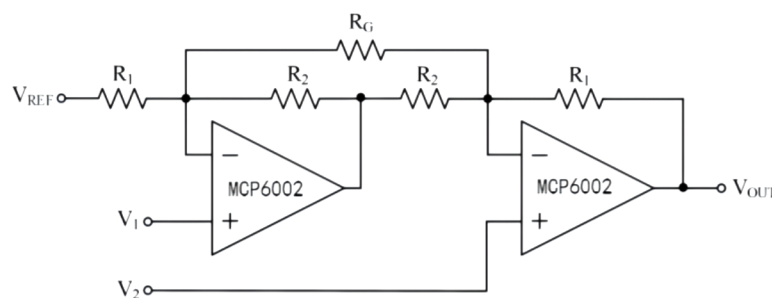

Figure 14 Differential Amplifier

The circuit shown in Figure 14 performs the difference function. If the resistors ratios are equal  $R_4/R_3 = R_2/R_1$ , then:

$$V_{OUT} = (V_p - V_n) \times R_2/R_1 + V_{REF}$$

## 2. INSTRUMENTATION AMPLIFIER



$$V_{OUT} = (V_1 - V_2) \times (1 + R_1/R_2 + 2R_1/R_G) +$$

$$V_{REF}$$

Figure 15 Instrumentation Amplifier

The XBLW MCP6001/6002/6004 family is well suited for conditioning sensor signals in battery-powered

applications. Figure 15 shows a two op-amp instrumentation amplifier, using the XBLW MCP6002op-amps. The circuit works well for applications requiring rejection of common-mode noise at higher gains. The reference voltage ( $V_{REF}$ ) is supplied by a low-impedance source. In single voltage supply applications, the  $V_{REF}$  is typically  $V_s/2$ .

### 3. BUFFERED CHEMICAL SENSORS

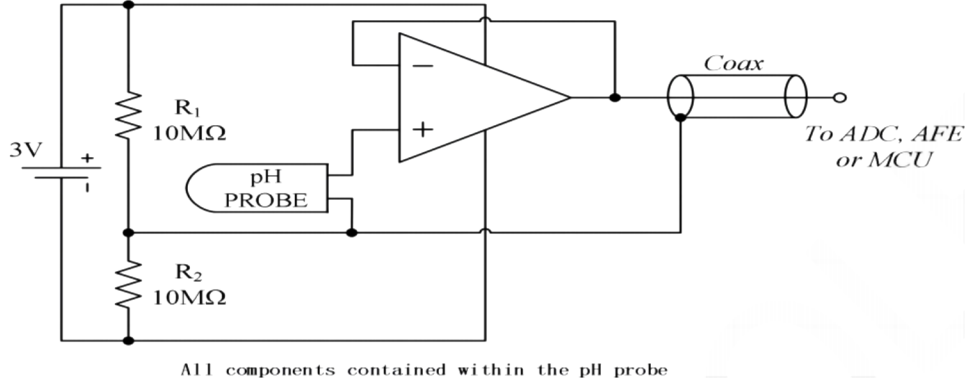
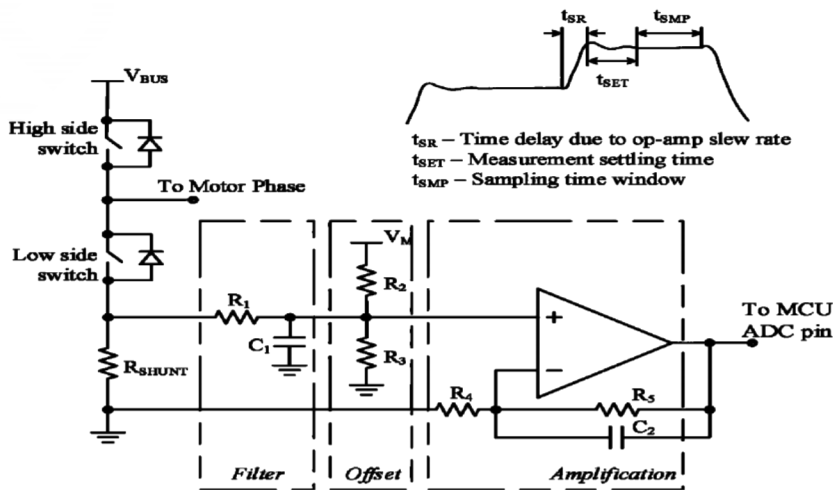

Figure 16 Buffered pH Probe

The XBLW MCP6001/6002/6004 family has input bias current in the pA range. This is ideal in buffering high impedance chemical sensors, such as pH probes. As an example, the circuit in Figure 16 eliminates expensive low-leakage cables that is required to connect a pH probe (general purpose combination pH probes, e.g Corning 476540) to metering ICs such as ADC, AFE and/or MCU. An XBLW MCP6001/6002/6004 op-amp and a lithium battery are housed in the probe assembly. A conventional low-cost coaxial cable can be used to carry the op-amp’s output signal to subsequent ICs for pH reading.

### 4. SHUNT-BASED CURRENT SENSING AMPLIFIER

The current sensing amplification shown in Figure 8 has a slew rate of  $2\pi fV_{PP}$  for the output of sine wave signal, and has a slew rate of  $2fV_{PP}$  for the output of triangular wave signal. In most of motor control systems, the PWM frequency is at 10kHz to 20kHz, and one cycle time is  $100\mu s$  for a 10kHz of PWM frequency. In current shunt monitoring for a motor phase, the phase current is converted to a phase voltage signal for ADC sampling. This sampling voltage signal must be settled before entering the ADC. As the Figure 19 shown, the total settling time of a current shunt monitor circuit includes: the rising edge delay time ( $t_{SR}$ ) due to the op-amp’s slew rate, and the measurement settling time ( $t_{SET}$ ). For a 3-shunt solution in motor phase current sensing, if the smaller duty cycle of the PWM is defined at 45% (In fact, the phase with minimum PWM duty cycle, such as 5%, is not detected current directly, and it can be calculated from the other two phase currents), and the  $t_{SR}$  is required at 20% of a total time window for a phase current monitoring, in case of a 3.3V motor control system(3.3V MCU with 12-bit ADC), the op-amp’s slew rate should be more than:



$$3.3V / (100\mu s \times 45\% \times 20\%) = 0.37 V/\mu s$$

At the same time, the op-amp’s bandwidth should be much greater than the PWM frequency, like 10 time at least.

## Package Information

- SOP-8

Symbol	Dimensions In Millimeters		Symbol	Dimensions In Inches	
	Min (mm)	Max (mm)		Min (in)	Max (in)
A	1.350	1.750	A	0.053	0.069
A1	0.100	0.250	A1	0.004	0.010
A2	1.350	1.550	A2	0.053	0.061
b	0.330	0.510	b	0.013	0.020
c	0.170	0.250	c	0.006	0.010
D	4.700	5.100	D	0.185	0.200
E	3.800	4.000	E	0.150	0.157
E1	5.800	6.200	E1	0.228	0.224
e	1.270 (BSC)		e	0.050 (BSC)	
L	0.400	1.270	L	0.016	0.050
$\theta$	0°	8°	$\theta$	0°	8°

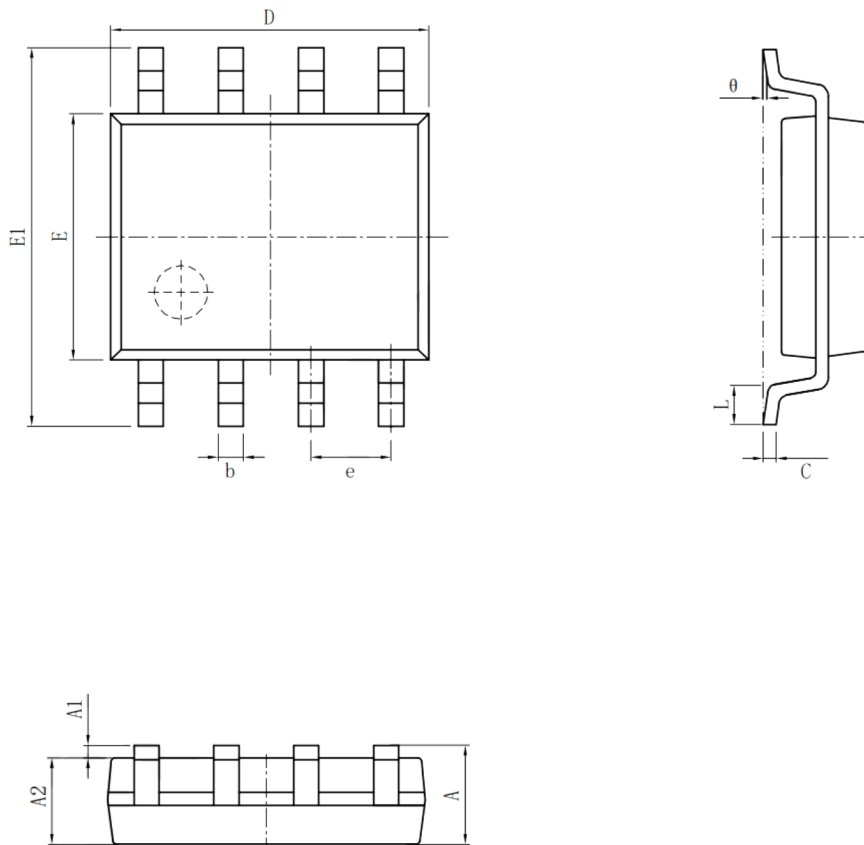

• SOP-14

Symbol	Dimensions In Millimeters		Symbol	Dimensions In Inches	
	Min (mm)	Max (mm)		Min (in)	Max (in)
A	1.350	1.750	A	0.050	0.068
A1	0.100	0.250	A1	0.004	0.009
A2	1.100	1.650	A2	0.040	0.060
B	0.330	0.510	B	0.010	0.020
C	0.190	0.250	C	0.007	0.009
D	8.550	8.750	D	0.330	0.340
E	3.800	4.000	E	0.150	0.150
e	1.27		e	0.05	
H	5.800	6.200	H	0.220	0.240
h	0.250	0.500	h	0.009	0.020
L	0.400	1.270	L	0.015	0.050
k	8° (max)		k	8° (max)	

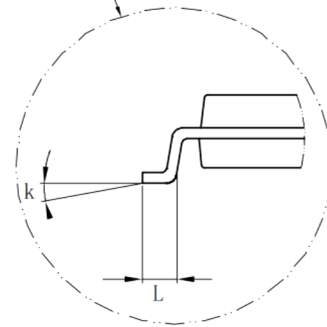
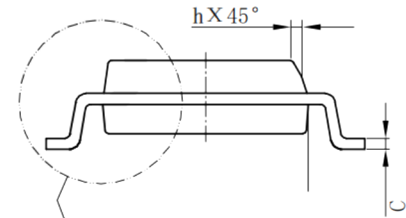
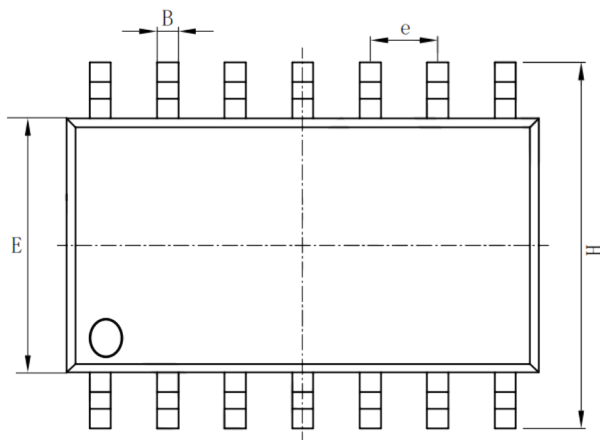
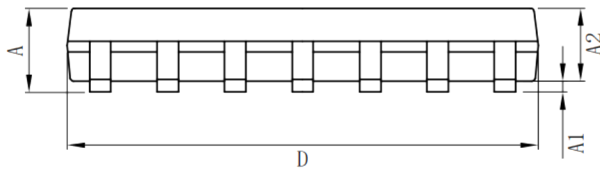

• SOT23-5

SIZE SYMBOL	Dimensions In Millimeters		SIZE SYMBOL	Dimensions In Inches	
	MIN (mm)	MAX (mm)		MIN (in)	MAX (in)
A	1.050	1.250	A	0.041	0.049
A1	0.000	0.100	A1	0.000	0.004
A2	1.050	1.150	A2	0.041	0.045
b	0.300	0.500	b	0.012	0.020
c	0.100	0.200	c	0.004	0.008
D	2.820	3.020	D	0.111	0.119
E	1.500	1.700	E	0.059	0.067
E1	2.650	2.950	E1	0.104	0.116
e	0.95 (BSC)		e	0.037 (BSC)	
e1	1.800	2.000	e1	0.071	0.079
L	0.300	0.600	L	0.012	0.024
$\theta$	0°	8°	$\theta$	0°	8°

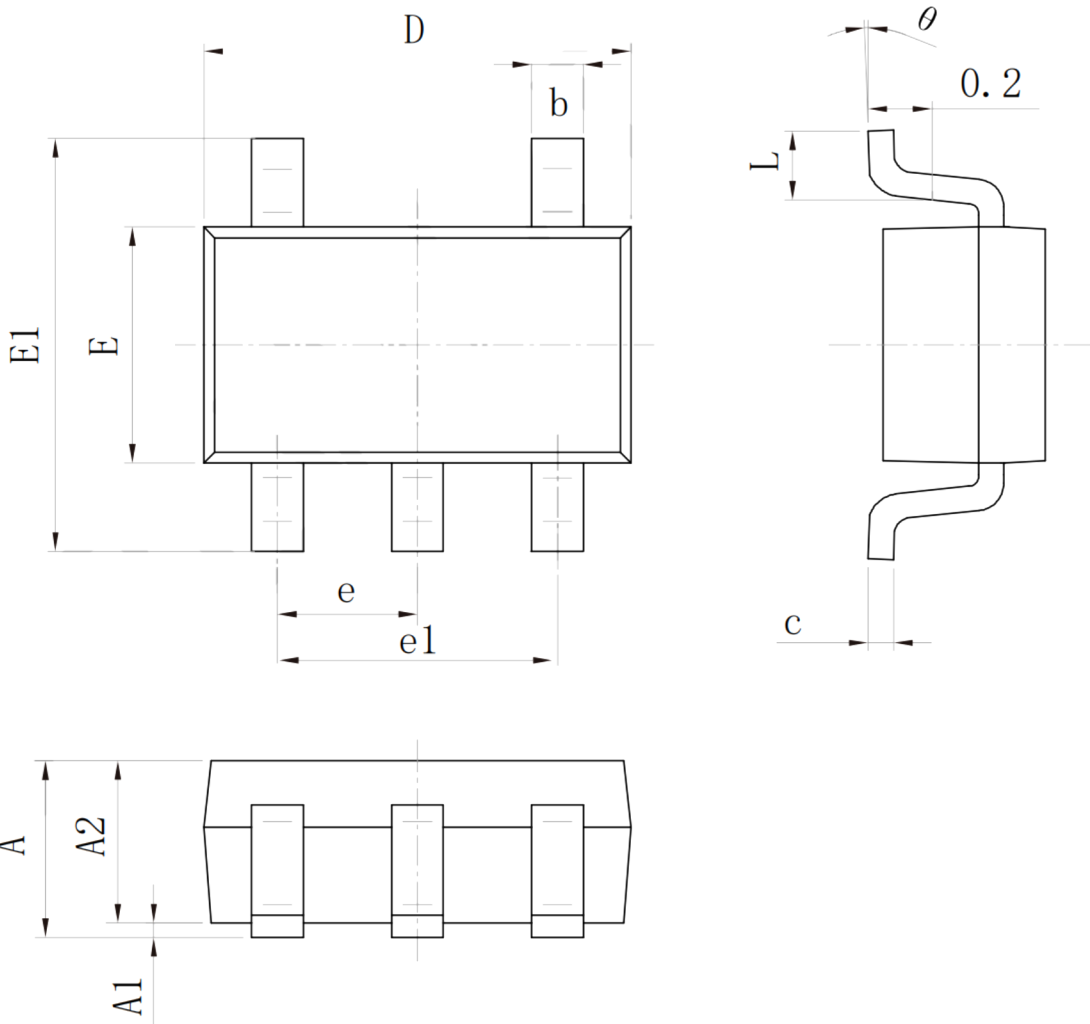

• TSSOP-14

Symbol	Size	Dimensions In Millimeters		Symbol	Size	Dimensions In Inches	
		Min (mm)	Max (mm)			Min (in)	Max (in)
A			1.200	A			0.047
A1		0.050	0.150	A1		0.002	0.006
A2		0.800	1.050	A2		0.031	0.041
b		0.190	0.300	b		0.007	0.012
c		0.090	0.200	c		0.004	0.0089
D		4.900	5.100	D		0.193	0.201
E		6.200	6.600	E		0.244	0.260
E1		4.300	4.500	E1		0.169	0.176
e		0.65		e		0.0256	
L		0.450	0.750	L		0.018	0.030
L1		1.00		L1		0.039	
k		0°	8°	k		0°	8°

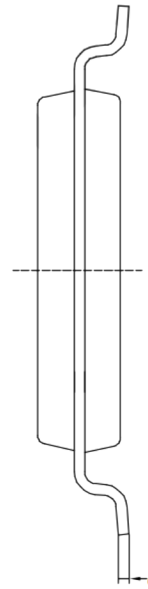
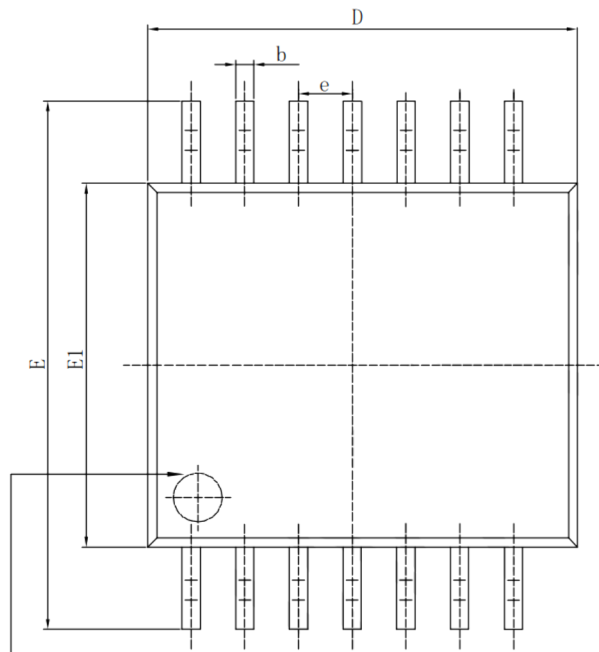

PIN #1 IDENT.

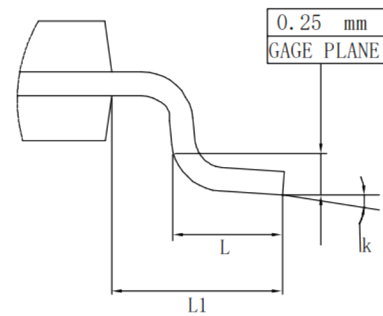
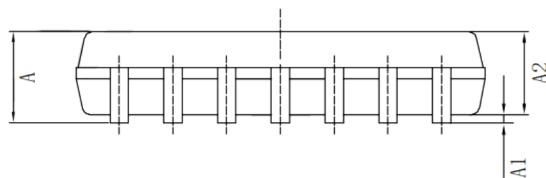

· MSOP-8

Size Symbol	Dimensions In Millimeters		Size Symbol	Dimensions In Inches	
	Min (mm)	Max (mm)		Min (in)	Max (in)
A	0.820	1.100	A	0.320	0.043
A1	0.020	0.150	A1	0.001	0.006
A2	0.750	0.950	A2	0.030	0.037
b	0.250	0.380	b	0.010	0.015
c	0.090	0.230	c	0.004	0.009
D	2.900	3.100	D	0.114	0.122
e	0.65 (BSC)		e	0.026 (BSC)	
E	2.900	3.100	E	0.114	0.122
E1	4.750	5.050	E1	0.187	0.199
L	0.400	0.800	L	0.016	0.031
$\theta$	0°	6°	$\theta$	0°	6°

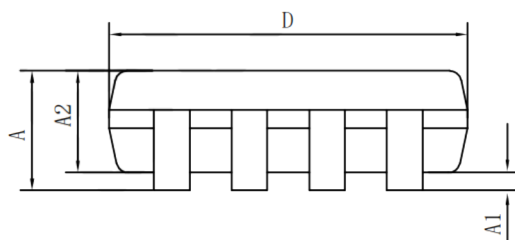
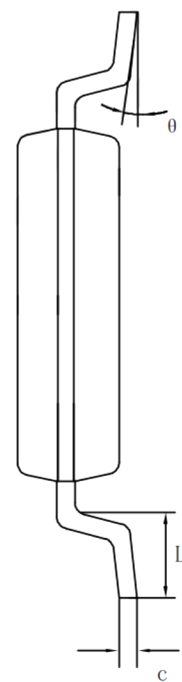
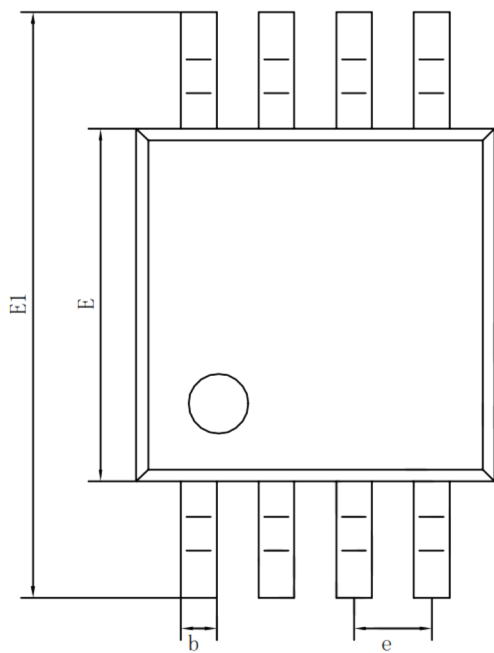

• SC70-5

Size Symbol	Dimensions In Millimeters		Size Symbol	Dimensions In Inches	
	Min (mm)	Max (mm)		Min (in)	Max (in)
A	0.800	1.100	A	0.035	0.043
A1	0.000	0.100	A1	0.000	0.004
A2	0.800	0.900	A2	0.035	0.039
b	0.150	0.350	b	0.006	0.014
C	0.080	0.150	C	0.003	0.006
D	1.850	2.150	D	0.079	0.087
E	1.100	1.400	E	0.045	0.053
E1	1.950	2.200	E1	0.085	0.096
e	0.85 (typ)		e	0.026 (typ)	
e1	1.200	1.400	e1	0.047	0.055
L	0.42 (ref)		L	0.021 (ref)	
L1	0.260	0.460	L1	0.010	0.018
$\theta$	0°	8°	$\theta$	0°	8°

