

## NPN Silicon Planar High Voltage Transistor

### FEATURES

- High  $BV_{CEO}$ ,  $BV_{CBO}$
- High current gain
- Compliant to RoHS Directive 2011/65/EU and in accordance to WEEE 2002/96/EC
- Halogen-Free according to IEC 61249-2-21

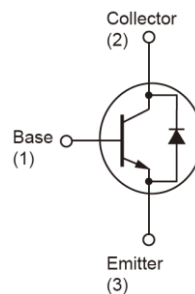
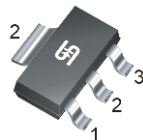
### APPLICATION

- Lighting
- Switch mode power supply

KEY PERFORMANCE PARAMETERS			
PARAMETER		VALUE	UNIT
$BV_{CEO}$		400	V
$BV_{CBO}$		600	V
$I_C$		300	mA
$V_{CE(SAT)}$	$I_C=50mA, I_B=5mA$	0.5	V



**SOT-223**



**Notes:** MSL 3 (Moisture Sensitivity Level) per J-STD-020

ABSOLUTE MAXIMUM RATINGS ( $T_A = 25^\circ\text{C}$ unless otherwise noted)				
PARAMETER		SYMBOL	LIMIT	UNIT
Collector-Base Voltage		$V_{CBO}$	600	V
Collector-Emitter Voltage		$V_{CES}$	600	V
Collector-Emitter Voltage @ $V_{BE}=0V$		$V_{CES}$	400	V
Emitter-Base Voltage		$V_{EBO}$	7	V
Collector Current	DC	$I_C$	0.3	A
	Pulse		1	A
Power Total Dissipation @ $T_A=25^\circ\text{C}$		$P_{DTOT}$	1	W
Maximum Operating Junction Temperature		$T_J$	+150	$^\circ\text{C}$
Storage Temperature Range		$T_{STG}$	-55 to +150	$^\circ\text{C}$

THERMAL PERFORMANCE			
PARAMETER	SYMBOL	LIMIT	UNIT
Junction to Ambient Thermal Resistance	$R_{\theta JA}$	91	$^\circ\text{C/W}$
Junction to Case Thermal Resistance	$R_{\theta JC}$	25	$^\circ\text{C/W}$

<b>ELECTRICAL SPECIFICATIONS</b> ( $T_A = 25^\circ\text{C}$ unless otherwise noted)						
PARAMETER	CONDITIONS	SYMBOL	MIN	TYP	MAX	UNIT
<b>Static</b> (Note 1)						
Collector-Base voltage	$I_C = 50\mu\text{A}$	$BV_{CBO}$	600	--	--	V
Collector-Emitter Saturation Voltage	$I_C = 100\mu\text{A}, V_{BE} = 0$	$BV_{CES}$	600	--	--	V
Collector-Emitter breakdown voltage	$I_C = 1\text{mA}$	$BV_{CEO}$	400	--	--	V
Emitter-Base breakdown voltage	$I_E = 50\mu\text{A}$	$BV_{EBO}$	7	--	--	V
Emitter cut-off current	$V_{EB} = 7\text{V}$	$I_{EBO}$	--	--	1.5	$\mu\text{A}$
Collector cut-off current	$V_{CB} = 600\text{V}$	$I_{CBO}$	--	--	0.5	$\mu\text{A}$
Collector-Emitter Cutoff Current	$V_{CE} = 400\text{V}$	$I_{CEO}$	--	--	1	$\mu\text{A}$
Collector-Emitter saturation voltage	$I_C = 50\text{mA}, I_B = 5\text{mA}$	$V_{CE(SAT)}$	---	--	0.5	V
Base-Emitter saturation voltage	$I_C = 50\text{mA}, I_B = 5\text{mA}$	$V_{BE(SAT)}$	--	--	1	V
DC Current Gain	$V_{CE} = 5\text{V}, I_C = 1\text{mA}$	$h_{FE1}$	100	--	--	
	$V_{CE} = 5\text{V}, I_C = 20\text{mA}$	$h_{FE2}$	90	--	300	
Transition Frequency	$V_{CE} = 10\text{V}, I_E = 20\text{mA}$	$f_T$	50	--	--	MHz
Output Capacitance	$V_{CB} = 20\text{V}, f = 1\text{MHz}$	$C_{ob}$	--	--	7	pF

**Notes:**

1. Pulse test:  $\leq 380\mu\text{s}$ , duty cycle  $\leq 2\%$
2. For DESIGN AID ONLY, not subject to production testing.

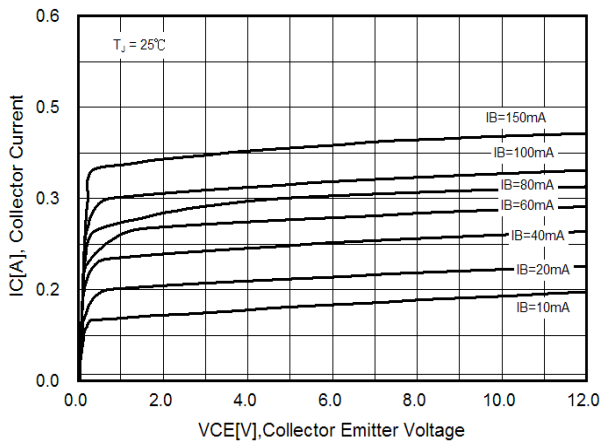
**ORDERING INFORMATION**

PART NO.	PACKAGE	PACKING
TSC966CW RPG	SOT-223	2,500pcs / 13"Reel

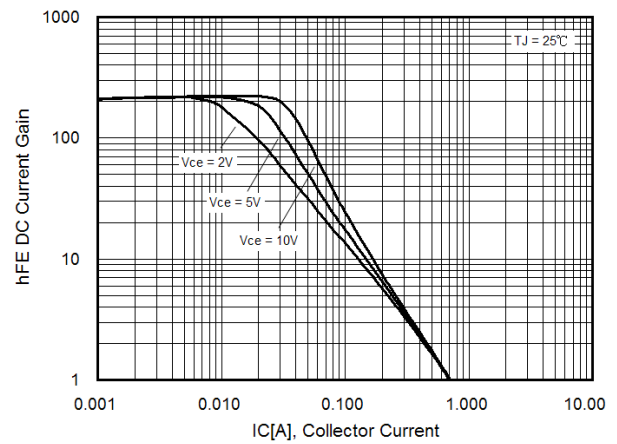
**Electrical Characteristics Curve**

( $T_a = 25^\circ\text{C}$ , unless otherwise noted)

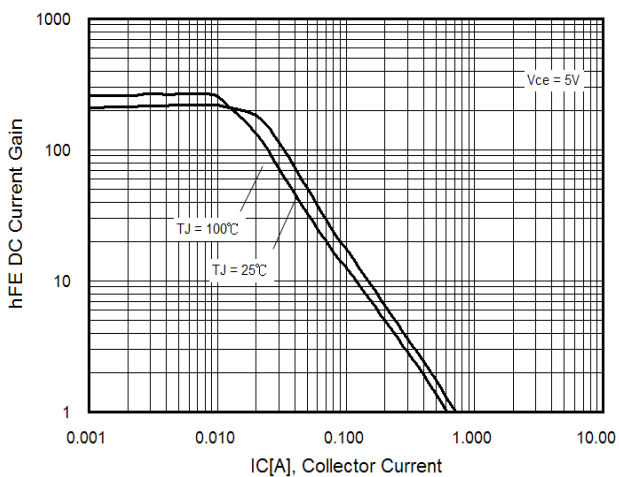
**Figure 1. Static Characteristics**



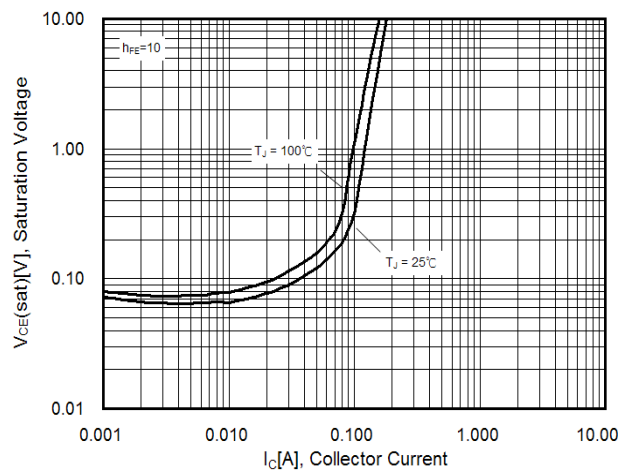
**Figure 2. DC Current Gain**



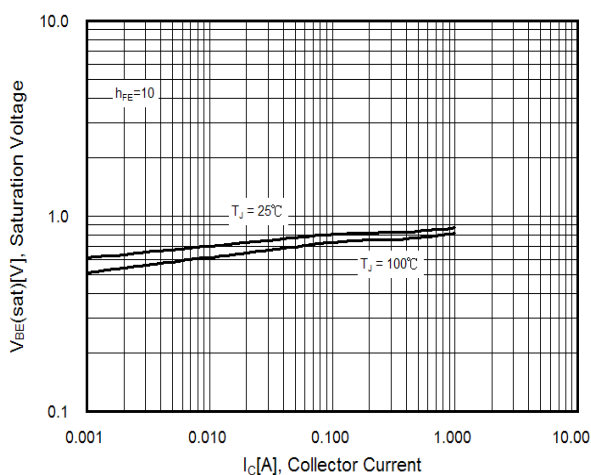
**Figure 3. DC Current Gain**



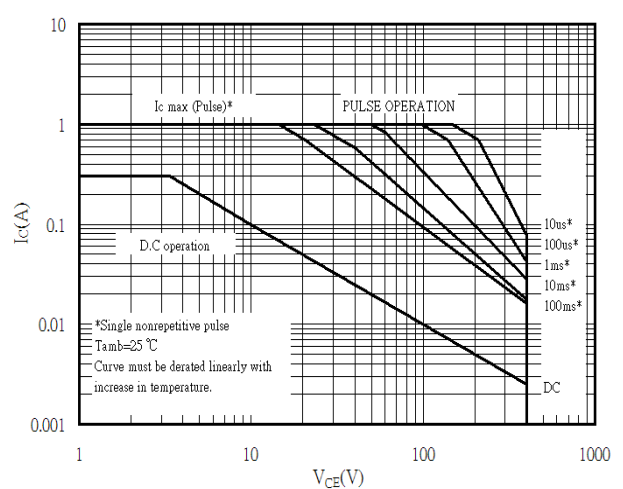
**Figure 4.  $V_{CE(sat)}$  vs  $I_c$**



**Figure 5.  $V_{BE(sat)}$  vs  $I_c$**

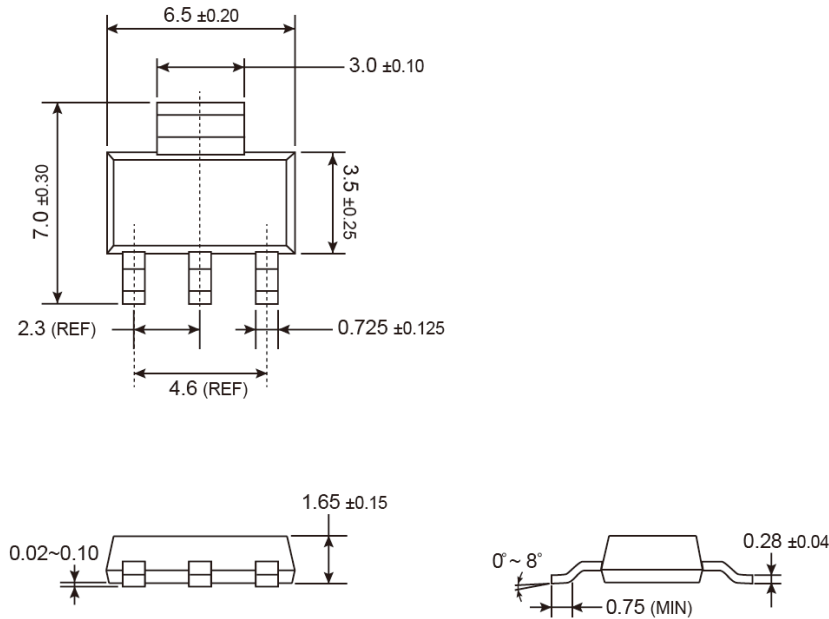


**Figure 6. Safety Operation Area**

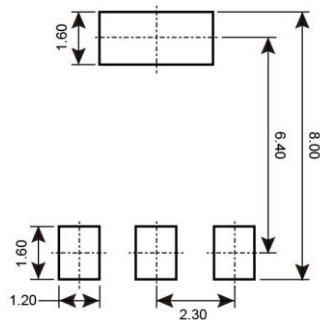


**PACKAGE OUTLINE DIMENSIONS** (Unit: Millimeters)

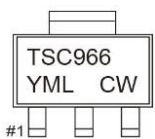
**SOT-223**



**SUGGESTED PAD LAYOUT** (Unit: Millimeters)



**Marking Diagram**



- Y** = Year Code
- M** = Month Code for Halogen Free Product
  - O** =Jan    **P** =Feb    **Q** =Mar    **R** =Apr
  - S** =May    **T** =Jun    **U** =Jul    **V** =Aug
  - W** =Sep    **X** =Oct    **Y** =Nov    **Z** =Dec
- L** = Lot Code

## Notice

Specifications of the products displayed herein are subject to change without notice. TSC or anyone on its behalf, assumes no responsibility or liability for any errors or inaccuracies.

Information contained herein is intended to provide a product description only. No license, express or implied, to any intellectual property rights is granted by this document. Except as provided in TSC's terms and conditions of sale for such products, TSC assumes no liability whatsoever, and disclaims any express or implied warranty, relating to sale and/or use of TSC products including liability or warranties relating to fitness for a particular purpose, merchantability, or infringement of any patent, copyright, or other intellectual property right.

The products shown herein are not designed for use in medical, life-saving, or life-sustaining applications. Customers using or selling these products for use in such applications do so at their own risk and agree to fully indemnify TSC for any damages resulting from such improper use or sale.