

Descriptions

The LM386 audio power amplifier is mainly used in low voltage consumer products. To minimize peripheral components, the voltage gain is built-in to 20. But add an external resistor and capacitor between 1 and 8 pins to set the voltage gain to any value up to 200. The input is ground-referenced and the output is automatically offset to half the supply voltage. At 6V supply voltage, its static power consumption is only 24mW, making LM386 especially suitable for battery-powered occasions.

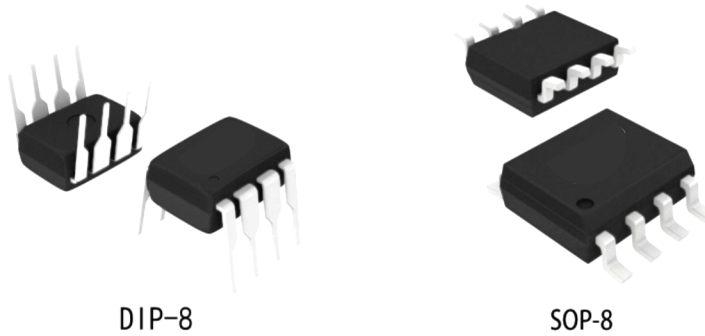

DIP-8

SOP-8

Feature

- Battery Operation
- Minimum External Parts
- Wide Supply Voltage Range: 4 V–12 V
- Low Quiescent Current Drain: 4 mA
- Voltage Gains from 20 to 200
- Ground-Referenced Input
- Self-Centering Output Quiescent Voltage
- Low Distortion: 0.2% ($AV = 20, VS = 6$)
- $RL = 8 \Omega, PO = 125 \text{ mW}, f = 1 \text{ kHz}$

Applications

- Active Filter
- AM-FM Radio Amplifiers
- Portable Tape Player Amplifiers
- Intercoms
- TV Sound Systems
- Line Drivers
- Ultrasonic Drivers
- Small Servo Drivers
- Power ConvertersIndustrial

Ordering Information

Product Model	Package Type	Marking	Packing	Packing Qty
XBLW LM386N	DIP-8	LM386N	Tube	2000Pcs/Box
XBLW LM386DTR	SOP-8	LM386	Tape	2500Pcs/Reel

Schematic

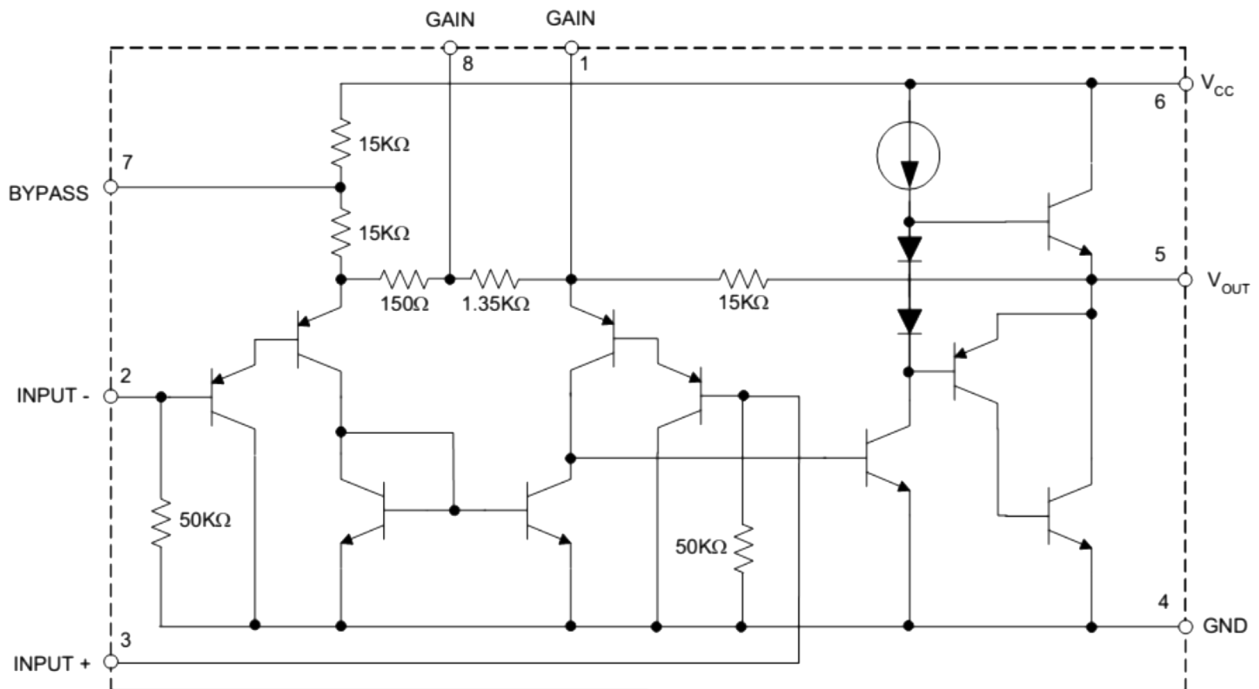

Pin Configurations

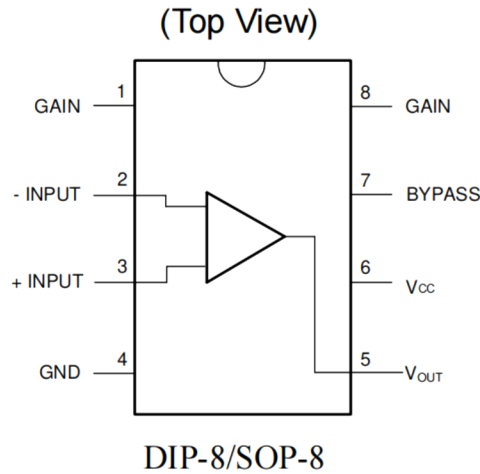

Pin Description

Pin		Function
No.	Name	
1	GAIN	Gain setting pin
2	- INPUT	Inverting input
3	+INPUT	Noninverting input
4	GND	Ground reference
5	V _{OUT}	Output
6	V _{CC}	Power supply voltage
7	BYPASS	Bypass decoupling path
8	GAIN	Gain setting pin

Absolute Maximum Ratings

($T_{amb}=25^{\circ}\text{C}$, Unless otherwise stated)

Name	Symbol	Value	Unit
Input Voltage	V_{IN}	± 0.4	V
Supply Voltage	V_{CC}	15	V
Package Dissipation	PD	660	mW
Welding temperature (10s)	T_s	260	$^{\circ}\text{C}$
Junction temperature	T_j	150	$^{\circ}\text{C}$
Operating temperature	T_{amb}	$0\sim 70$	$^{\circ}\text{C}$
Storage temperature	T_{stg}	$-40\sim 125$	$^{\circ}\text{C}$

Electrical Characteristics

($T_{amb}=25^{\circ}\text{C}$, $V_{CC}=6\text{V}$, $R_L=8\Omega$, $f=1\text{kHz}$)

Parameters	Symbol	Condition of test	Min	Typ	Max	Unit
Operating Supply Voltage	V_{CC}		4		12	V
Quiescent Current	I_{CC}	$V_{CC}=6\text{V}$, $V_{IN}=0$		4	8	mA
Output Power	P_o	$V_{CC}=6\text{V}$, $R_L=8\Omega$, THD=10%	250	325	-	mW
		$V_{CC}=9\text{V}$, $R_L=8\Omega$, THD=10%	500	700	-	mW
Voltage Gain	A_V	$V_{CC}=6\text{V}$, $f=1\text{kHz}$	-	26	-	dB
		$10\mu\text{F}$ from Pin 1 to 8		46		
Bandwidth	BW	$V_{CC}=6\text{V}$, Pins 1 and 8 Open	-	300	-	kHz
Total Harmonic Distortion	THD	$V_{CC}=6\text{V}$, $R_L=8\Omega$, $P_o=125\text{mW}$, $f=1\text{kHz}$ Pins 1 and 8 Open	-	0.2	-	%
Power Supply Rejection Ratio	PSRR	$V_{CC}=6\text{V}$, $f=1\text{kHz}$, CBYPASS=10 μF , Pins 1 and 8 Open, Referred to Output		50		dB
Input Resistance	R_{IN}			50		k Ω
Input Bias Current	I_B	$V_{CC}=6\text{V}$, Pins 2 and 3 Open	-	250	-	nA

Typical Application

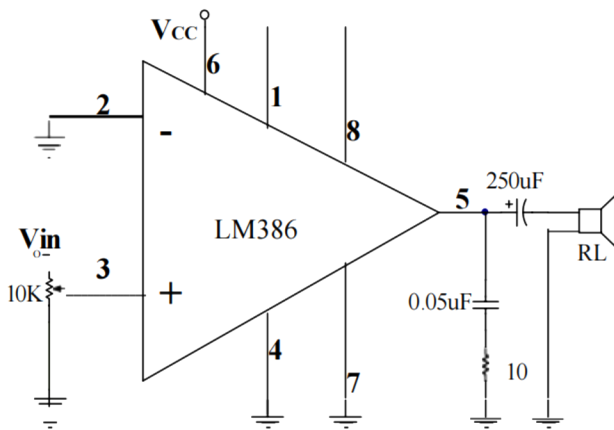

Figure 1. With Gain = 20

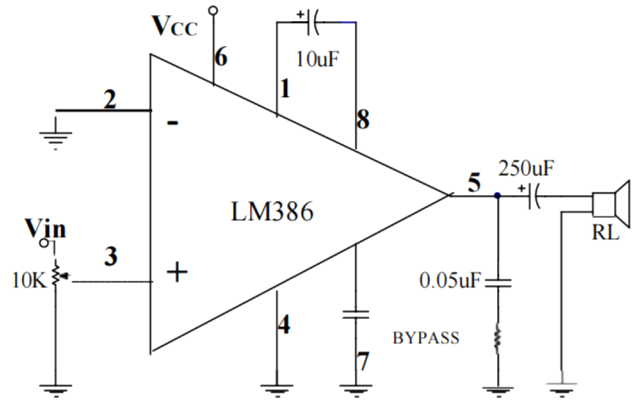

Figure 2. With Gain = 200

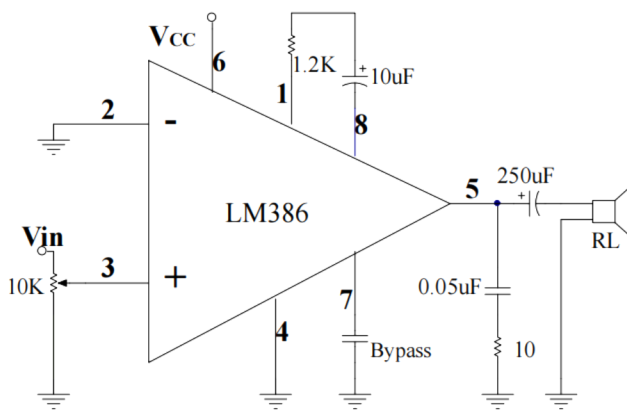

Figure 3 .With Gain = 50

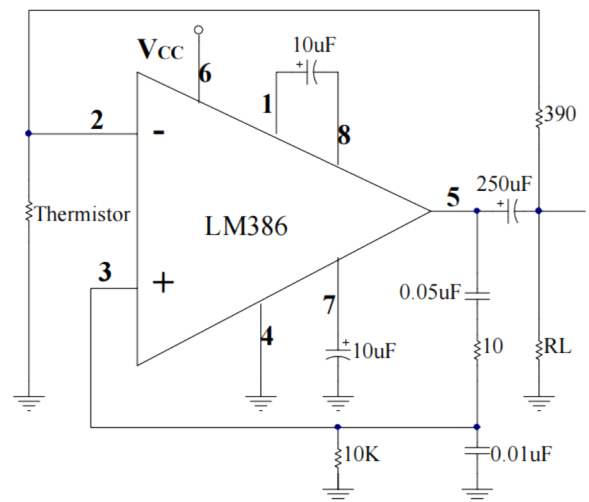

Figure 4 . Low distortion bridge oscillator

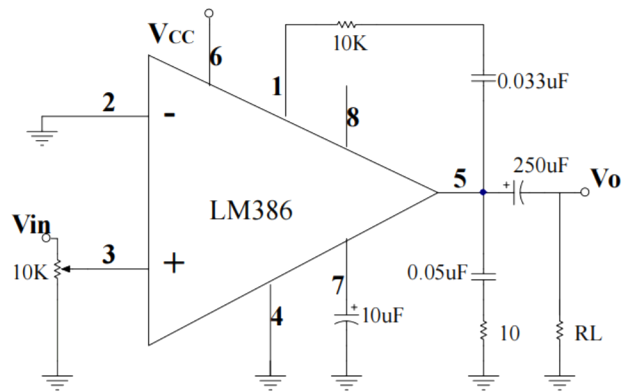

Figure 5 . Low frequency boost amplifier

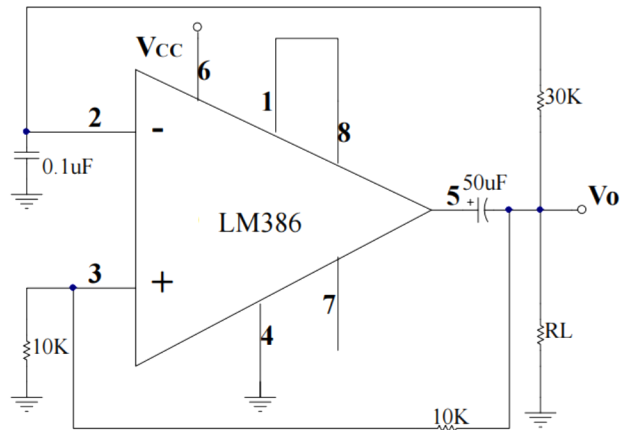

Figure 6 . Square wave oscillator

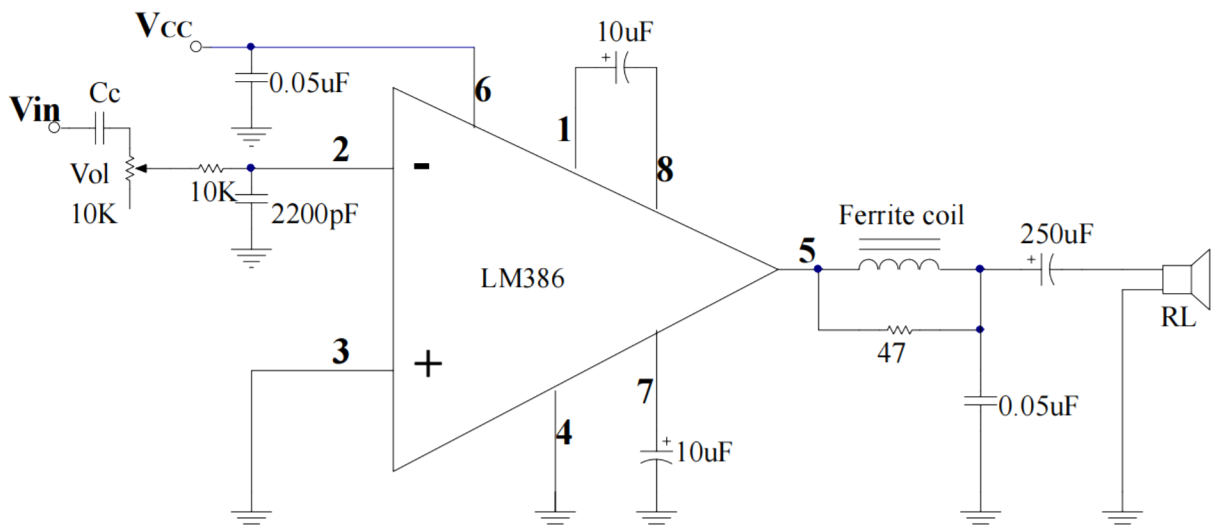

Figure 7 . Amplitude modulation radio audio amplifier

Application points

1、 Gain Control

To make the LM386 a more versatile amplifier, two pins (1 and 8) are provided for gain control. With pins 1 and 8 open the 1.35-k Ω resistor sets the gain at 20 (26 dB). If a capacitor is put from pin 1 to 8, bypassing the 1.35-k Ω resistor, the gain will go up to 200 (46 dB). If a resistor is placed in series with the capacitor, the gain can be set to any value from 20 to 200. Gain control can also be done by capacitively coupling a resistor (or FET) from pin 1 to ground.

Additional external components can be placed in parallel with the internal feedback resistors to tailor the gain and frequency response for individual applications. For example, we can compensate poor speaker bass response by frequency shaping the feedback path. This is done with a series RC from pin 1 to 5 (paralleling the internal 15-k Ω resistor). For 6 dB effective bass boost: $R \approx 15 \text{ k}\Omega$, the lowest value for good stable operation is $R = 10 \text{ k}\Omega$ if pin 8 is open. If pins 1 and 8 are bypassed then R as low as 2 k Ω can be used. This restriction is because the amplifier is only compensated for closed-loop gains greater than 9.

2、 Input Biasing

The schematic shows that both inputs are biased to ground with a 50 k Ω resistor. The base current of the input transistors is about 250 nA, so the inputs are at about 12.5 mV when left open. If the dc source resistance driving the LM386 is higher than 250 k Ω it will contribute very little additional offset (about 2.5 mV at the input, 50 mV at the output). If the dc source resistance is less than 10 k Ω , then shorting the unused input to ground will keep the offset low (about 2.5 mV at the input, 50 mV at the output). For dc source resistances between these values we can eliminate excess offset by putting a resistor from the unused input to ground, equal in value to the dc source resistance. Of course all offset problems are eliminated if the input is capacitively coupled.

When using the LM386 with higher gains (bypassing the 1.35 k Ω resistor between pins 1 and 8) it is necessary to bypass the unused input, preventing degradation of gain and possible instabilities. This is done with a 0.1 μ F capacitor or a short to ground depending on the dc source resistance on the driven input.

Package Information

- DIP-8

Symbol	Size	Dimensions In Millimeters		Symbol	Size	Dimensions In Inches	
		Min (mm)	Max (mm)			Min (in)	Max (in)
A		3.710	4.310	A		0.146	0.170
A1		0.510		A1		0.020	
A2		3.200	3.600	A2		0.126	0.142
B		0.380	0.570	B		0.015	0.022
B1		1.524 (BSC)		B1		0.060 (BSC)	
C		0.204	0.360	C		0.008	0.014
D		9.000	9.400	D		0.354	0.370
E		6.200	6.600	E		0.244	0.260
E1		7.320	7.920	E1		0.288	0.312
e		2.540 (BSC)		e		0.100 (BSC)	
L		3.000	3.600	L		0.118	0.142
E2		8.400	9.000	E2		0.331	0.354

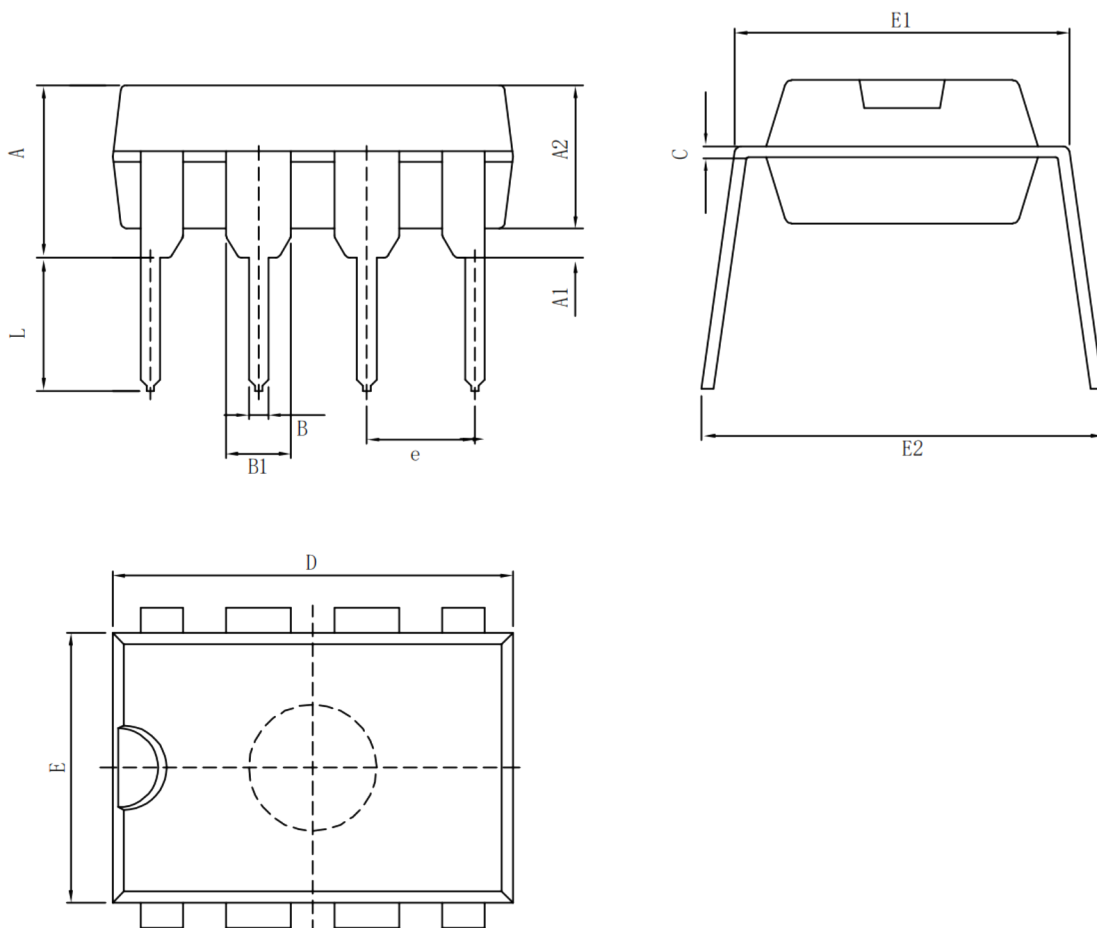

• SOP-8

Symbol	Dimensions In Millimeters		Symbol	Dimensions In Inches	
	Min (mm)	Max (mm)		Min (in)	Max (in)
A	1.350	1.750	A	0.053	0.069
A1	0.100	0.250	A1	0.004	0.010
A2	1.350	1.550	A2	0.053	0.061
b	0.330	0.510	b	0.013	0.020
c	0.170	0.250	c	0.006	0.010
D	4.700	5.100	D	0.185	0.200
E	3.800	4.000	E	0.150	0.157
E1	5.800	6.200	E1	0.228	0.224
e	1.270 (BSC)		e	0.050 (BSC)	
L	0.400	1.270	L	0.016	0.050
θ	0°	8°	θ	0°	8°

