

## Descriptions

The LM324 consists of four independent, high gain operational amplifiers with frequency compensation implemented internally. It suits for radio recorders and audio systems as tone equalization network and also used in other situations.

The chip is available in DIP 14 or SOP 14 plastic package.

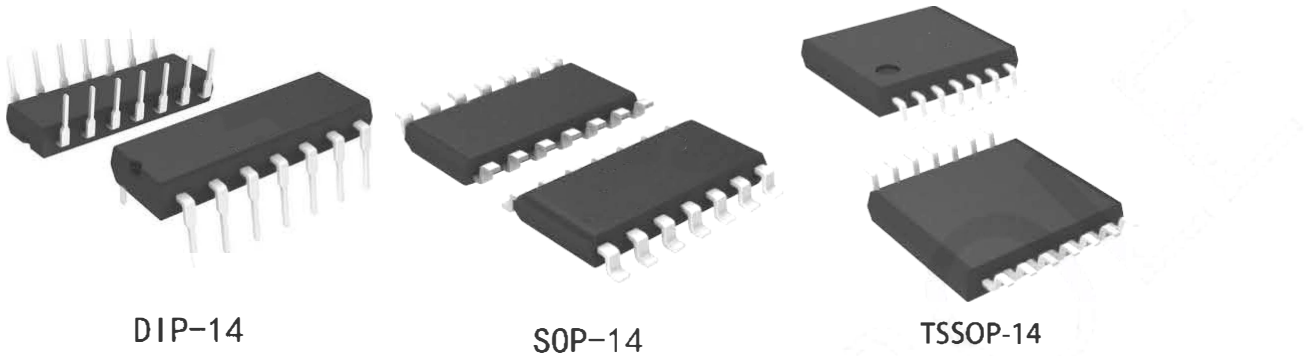

## Feature

- No External Phase Compensation Circuit Required
- Supply Voltage Range:
  - Single Power Supply:  $V_{cc} = 3V \sim 24V$
  - Dual Power Supply:  $V_{cc} = \pm 1.5V \sim \pm 12V$
- Low Power Consumption:  $I_{cc} = 0.6mA$  (typical) ( $R_L = \infty$ )
- Input Voltage Range Close To Ground Level

## Applications

- Transducer Amplifiers
- DC Gain Blocks
- Conventional Op Amp Circuits

## Ordering Information

Product Model	Package Type	Marking	Packing	Packing Qty
XBLW LM324N	DIP-14	LM324N	Tube	1000pcs/ Box
XBLW LM324DTR	SOP-14	LM324	Tape	2500pcs/ Reel
XBLW LM324TDTR	TSSOP-14	LM324	Tape	3000pcs/ Reel

## Principle Introduction

LM324 is composed of four identical operational amplifiers. The unit circuit is shown in the figure. Its working principle is briefly described as follows: The input signal is added to the base of T1 and T4, and after differential amplification; T8 and T9 form the intermediate stage in compound amplification; the output stage is composed of T10 ~ T13. Among them, T12 is a protection tube. When the output current is too large, the voltage drop on R increases, causing T12 to saturate conducting, and the collector potential of T12 decreases to nearly  $1/2 V_{cc}$ , so that the push-pull tubes T10, T11 and T13 are cut off, thereby playing a protective role. Capacitor C is a phase compensation capacitor.

### Circuit Diagram

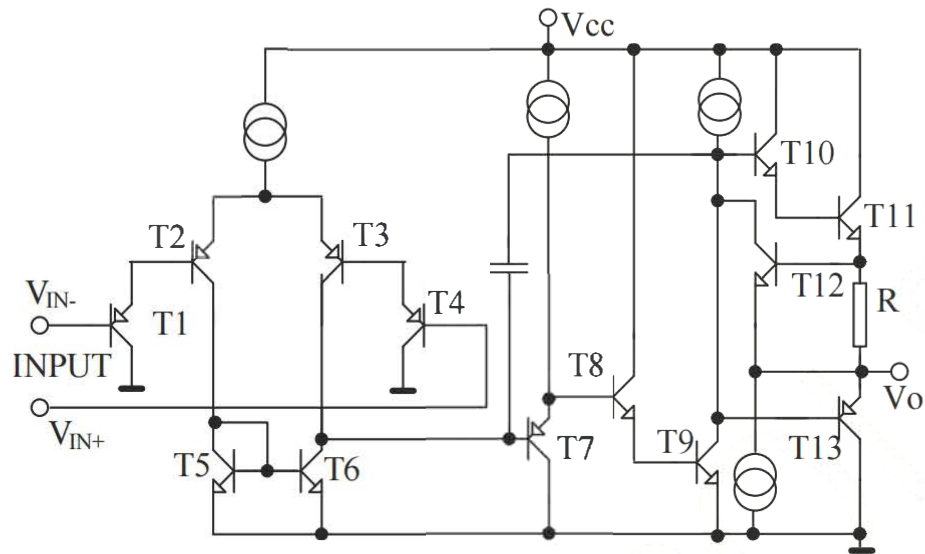

### Pin Connections

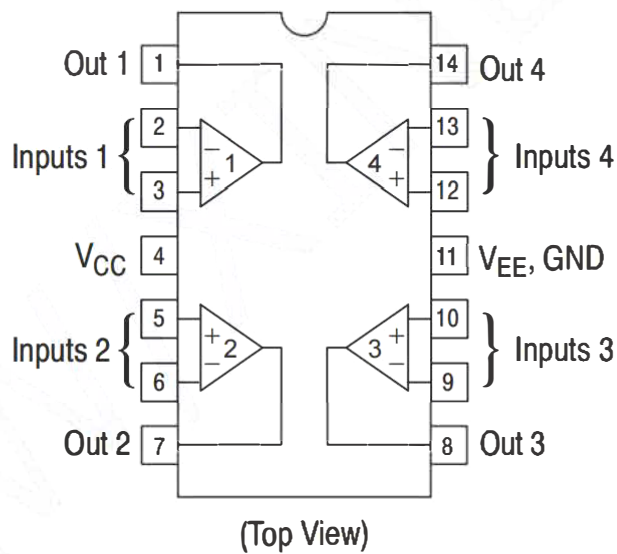

### Pins Configuration

NO.	Function	Symbol	NO.	Function	Symbol
1	Output 1	OUT 1	8	Output 3	OUT 3
2	Reverse Input 1	IN - (1)	9	Reverse Input 3	IN - (3)
3	Forward Input 2	IN+ (2)	10	Positive Input 3	IN+ (3)
4	Power Supply	VCC	11	Ground	GND
5	Forward Input 2	IN+ (2)	12	Positive Input 4	IN+ (4)
6	Reverse Input 2	IN - (1)	13	Reverse Input 4	IN - (4)
7	Output 2	OUT 2	14	Output 4	OUT4

## Absolute Maximum Ratings

TA=25°C, unless otherwise noted

Parameter Name	Symbol	Test conditions	Rating	Unit
Power Supply	V <sub>CC</sub>		24	V
Differential Input Voltage	V <sub>ID</sub>		24	V
Maximum Input Voltage	V <sub>IN</sub>		-0.3 ~ 24	V
Allowable Power Dissipation	P <sub>D</sub>		600	mW
Operating Temperature	T <sub>opr</sub>		0 ~ +70	°C
Storage Temperature	T <sub>stg</sub>		-55 ~ +125	°C

## Electrical Characteristics

Unless otherwise noted, T<sub>amb</sub>=25°C, V<sub>CC</sub>=5.0V

Parameters	Symbol	Test conditions	Min.	TYP.	Max.	Unit
Input Offset Voltage	V <sub>IO</sub>			±2	±7	mV
Input Offset Current	I <sub>IO</sub>	I <sub>in (+)</sub> / I <sub>in (-)</sub>		±5	±50	nA
Input Bias Current	I <sub>BA</sub>			45	250	nA
Input Common Mode Voltage Range	V <sub>ICM</sub>		0		V <sub>CC</sub> - 1.5	V
Common Mode Rejection Ratio	K <sub>CMR</sub>		65	80		dB
Strong Signal Voltage Gain	G <sub>V</sub>	V <sub>CC</sub> = 1.5V, R <sub>L</sub> ≥ 2KΩ	25	100		V / mA
Output Voltage Range	V <sub>O</sub>		0		V <sub>CC</sub> - 1.5	V
Power Supply Ripple Rejection Ratio	P <sub>SRR</sub>		65	100		dB
Channel Separation	C <sub>S</sub>	f = 1 kHz ~ 20 kHz		120		dB
Current Consumption (1)	I <sub>CC</sub>			0.6	2	mA
Current Consumption (2)	I <sub>CC</sub>	V <sub>CC</sub> = 20V		1.5	3	mA
Output Current (1)	I <sub>O</sub>	V <sub>in+</sub> = 1V, V <sub>in-</sub> = 0V	20	40		mA
Output Current (2)	I <sub>O</sub>	V <sub>in+</sub> = 0V, V <sub>in-</sub> = 1V	10	20		mA

Null refers to the Amplifier.

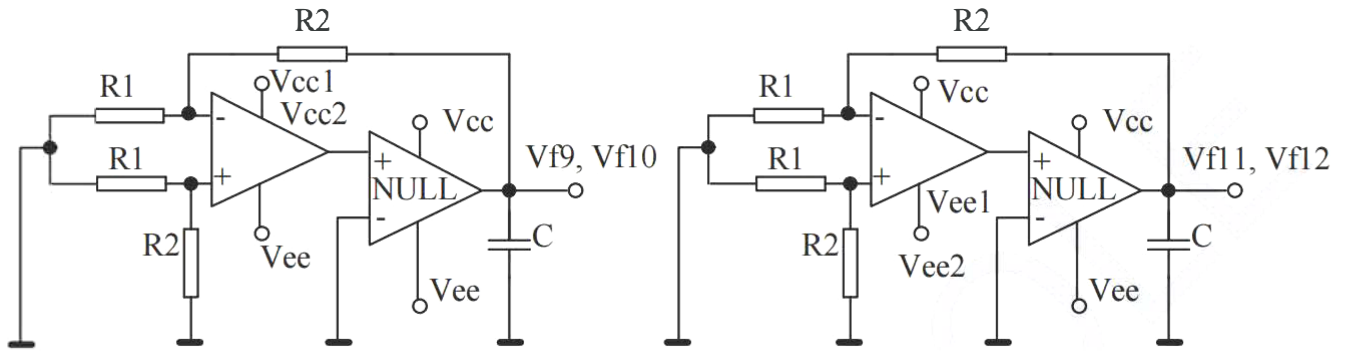

$$PSRR (+) = 20 \log \left| \frac{(V_{cc1} - V_{cc2}) (1 + R2/R1)}{(V_{f9} - V_{f10})} \right| \quad PSRR (-) = 20 \log \left| \frac{(V_{ee1} - V_{ee2}) (1 + R2/R1)}{(V_{f11} - V_{f12})} \right|$$

Power ripple rejection ratio PSRR test diagram

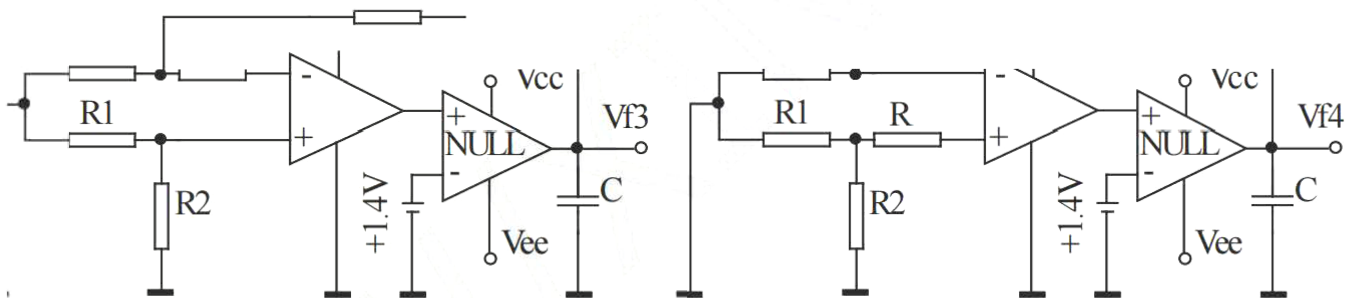

$$IBA = (V_{f4} - V_{f3}) / 2R (1 + R2/R1)$$

Input bias current IBA test diagram

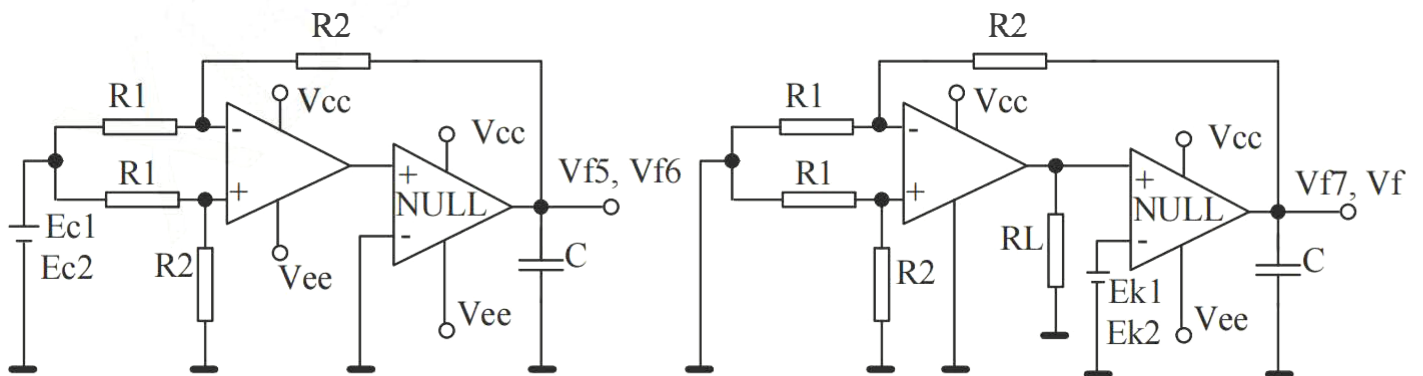

$$CMR = 20 \log \left| \frac{(E_{c1} - E_{c2}) (1 + R2/R1)}{(V_{f5} - V_{f6})} \right|$$

$$G_v = \frac{(E_{k1} - E_{k2}) (1 + R2/R1)}{(V_{f8} - V_{f7})}$$

Common-mode rejection CMR and common-mode input voltage range VICM test chart

Voltage gain Gv test diagram

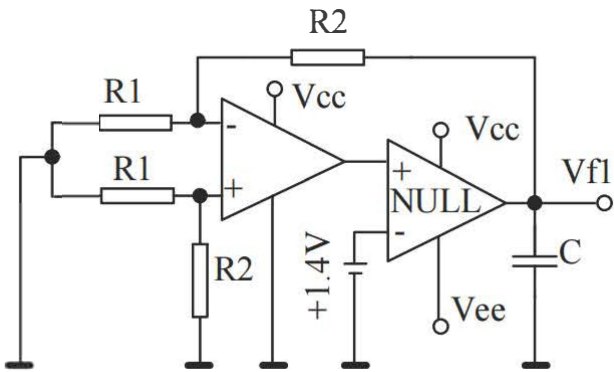

$$V_{io} = V_{f1} / (1 + R_2/R_1)$$

Input offset voltage  $V_{io}$  test diagram

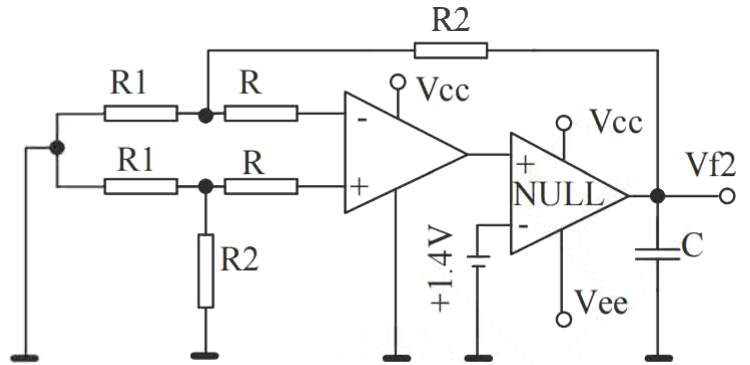

$$I_{io} = (V_{f2} - V_{f1}) / R (1 + R_2/R_1)$$

Input offset current  $I_{io}$  test diagram

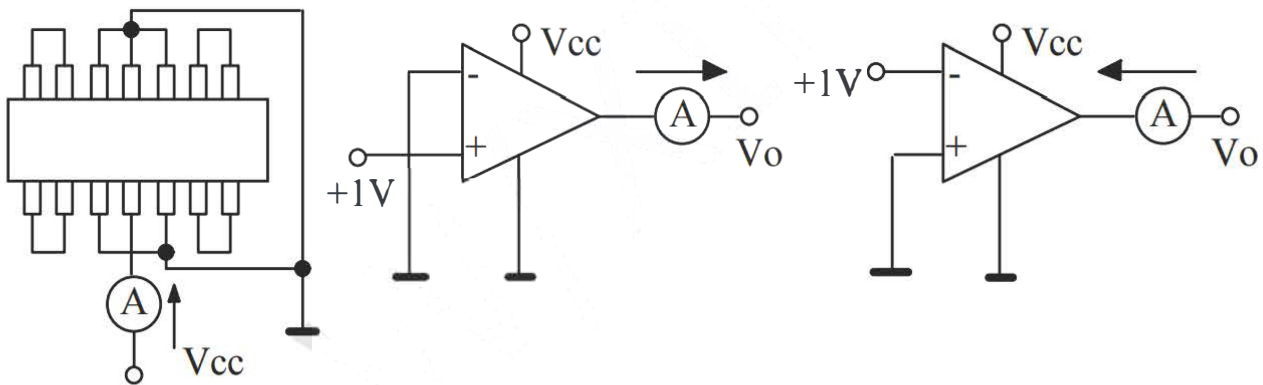

Consumption current  $I_{cc}$  and output current  $I_o$  test diagram

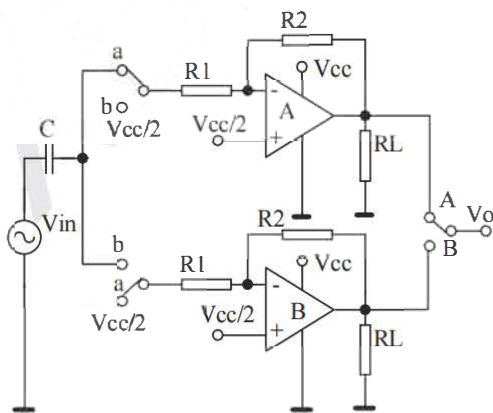

SW: A

$$C_s(A \rightarrow B) = 20 \log(R_2 * V_{OA}) / (R_1 * V_{OB})$$

SW: B

$$C_s(B \rightarrow A) = 20 \log(R_2 * V_{OB}) / (R_1 * V_{OA})$$

Channel separation  $C_s$  test diagram

Applications

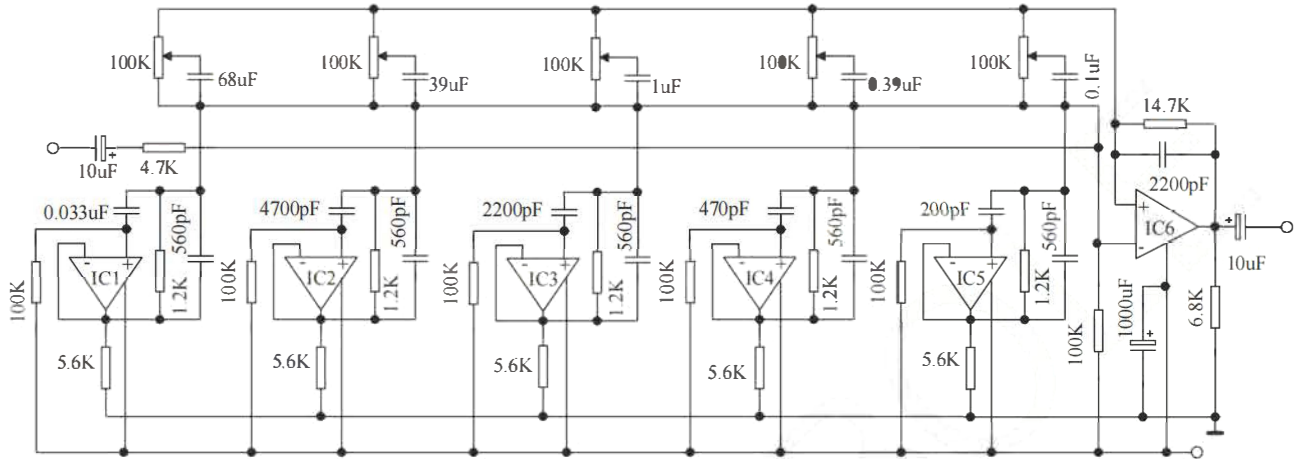

The LM324 is used in five-frequency tone control circuits

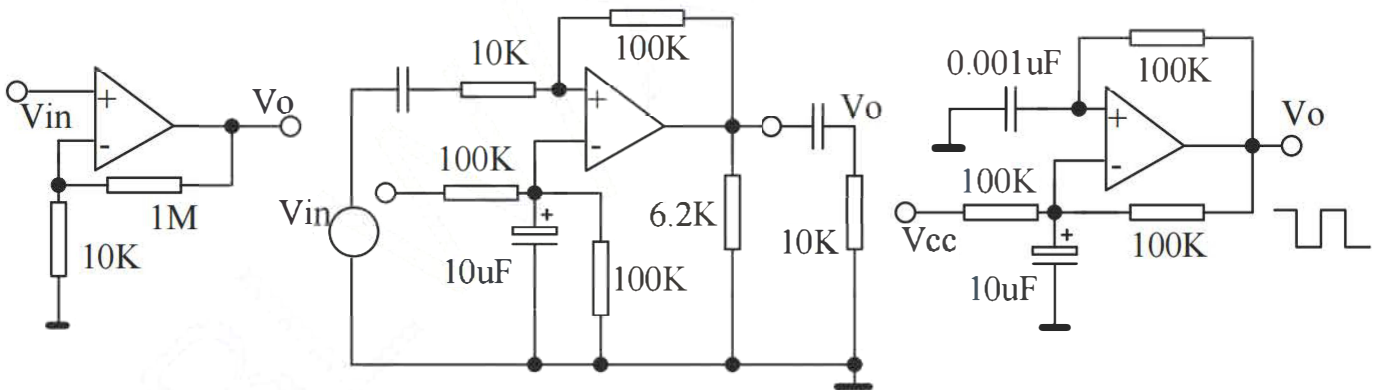

LM324 Other applications

## Package Information

### · DIP-14

Size Symbol	Dimensions In Millimeters		Size Symbol	Dimensions In Inches	
	Min (mm)	Max (mm)		Min (in)	Max (in)
A	3.710	4.310	A	0.146	0.170
A1	0.510		A1	0.020	
A2	3.200	3.600	A2	0.126	0.142
B	0.380	0.570	B	0.015	0.022
B1	1.524 (BSC)		B1	0.060 (BSC)	
C	0.204	0.360	C	0.008	0.014
D	18.800	19.200	D	0.740	0.756
E	6.200	6.600	E	0.244	0.260
E1	7.320	7.920	E1	0.288	0.312
e	2.540 (BSC)		e	0.100 (BSC)	
L	3.000	3.600	L	0.118	0.142
E2	8.400	9.000	E2	0.331	0.354

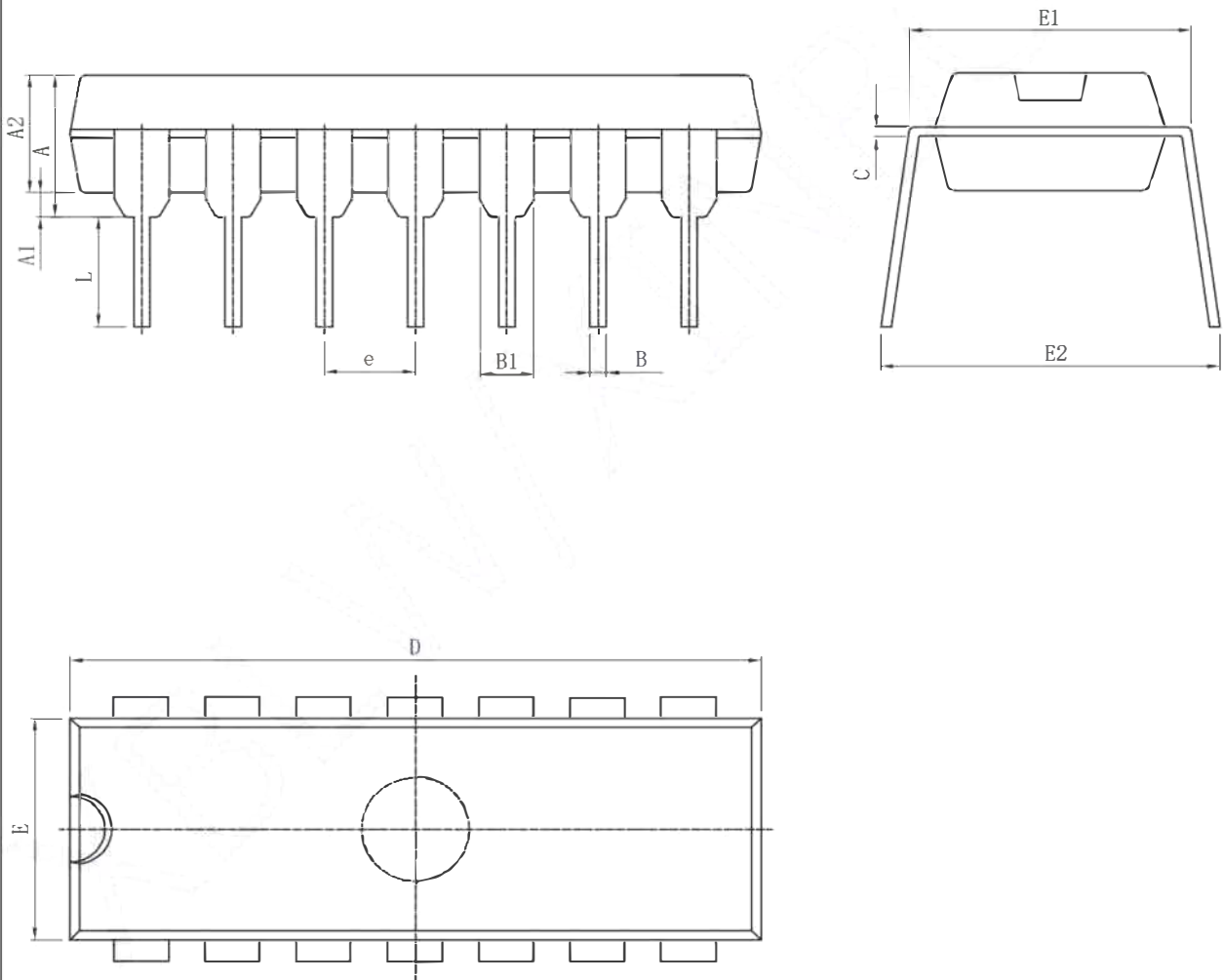

## · SOP-14

Symbol	Dimensions In Millimeters		Symbol	Dimensions In Inches	
	Min( mm)	Max( mm)		Min( in)	Max( in)
A	1.350	1.750	A	0.050	0.068
A1	0.100	0.250	A1	0.004	0.009
A2	1.100	1.650	A2	0.040	0.060
B	0.330	0.510	B	0.010	0.020
C	0.190	0.250	C	0.007	0.009
D	8.550	8.750	D	0.330	0.340
E	3.800	4.000	E	0.150	0.150
e	1.27		e	0.05	
H	5.800	6.200	H	0.220	0.240
h	0.250	0.500	h	0.009	0.020
L	0.400	1.270	L	0.015	0.050
k	8° (max)		k	8° (max)	

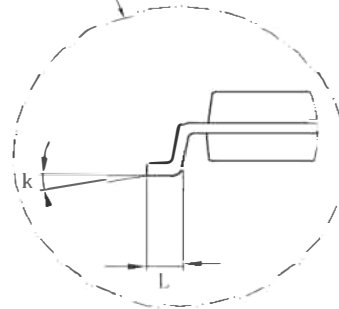
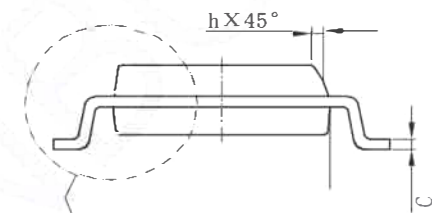
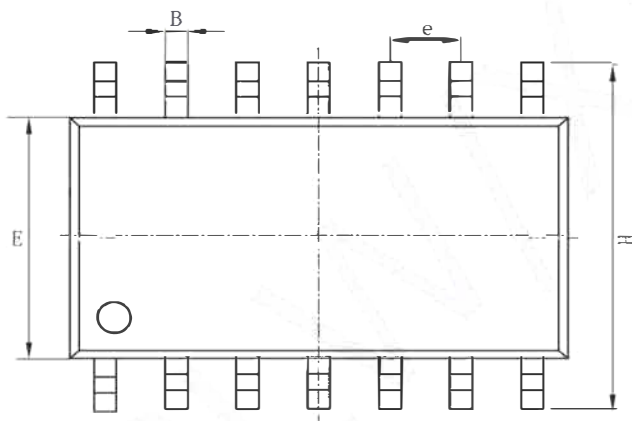
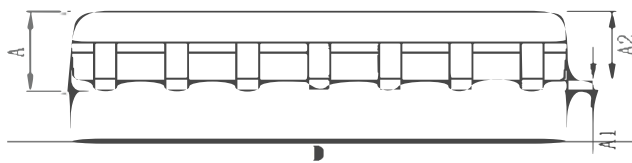

• TSSOP-14

Size Symbol	Dimensions In Millimeters		Size Symbol	Dimensions In Inches	
	Min (mm)	Max (mm)		Min (in)	Max (in)
A		1.200	A		0.047
A1	0.050	0.150	A1	0.002	0.006
A2	0.800	1.050	A2	0.031	0.041
b	0.190	0.300	b	0.007	0.012
c	0.090	0.200	c	0.004	0.0089
D	4.900	5.100	D	0.193	0.201
E	6.200	6.600	E	0.244	0.260
E1	4.300	4.500	E1	0.169	0.176
e		0.65	e		0.0256
L	0.450	0.750	L	0.018	0.030
L1		1.00	L1		0.039
k	0°	8°	k	0°	8°

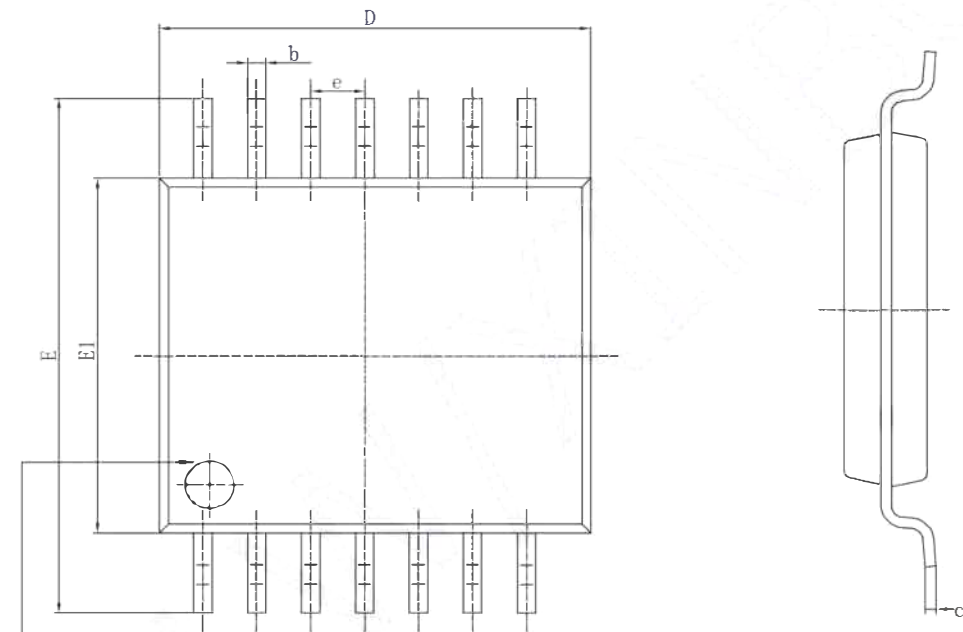

PIN #1 IDENT.

