

Very low offset single bipolar operational amplifier

Features

- Extremely low offset: 150 μ V/ max.
- Low input bias current: 1.8nA
- LOW V_{i0} drift: 0.5 μ V/ $^{\circ}$ C
- Ultra stable with time: 2 μ V/month max.
- Wide supply voltage range: \pm 3V to \pm 22V
- Temperature range: 0 $^{\circ}$ C to -105 $^{\circ}$ C

Description

The OP07 is a very high precision op-amp with an offset voltage maximum of 150 μ V.

Offering also low input current (1.8nA) and high gain (400V/mV), the OP07C is particularly suitable for instrumentation applications.

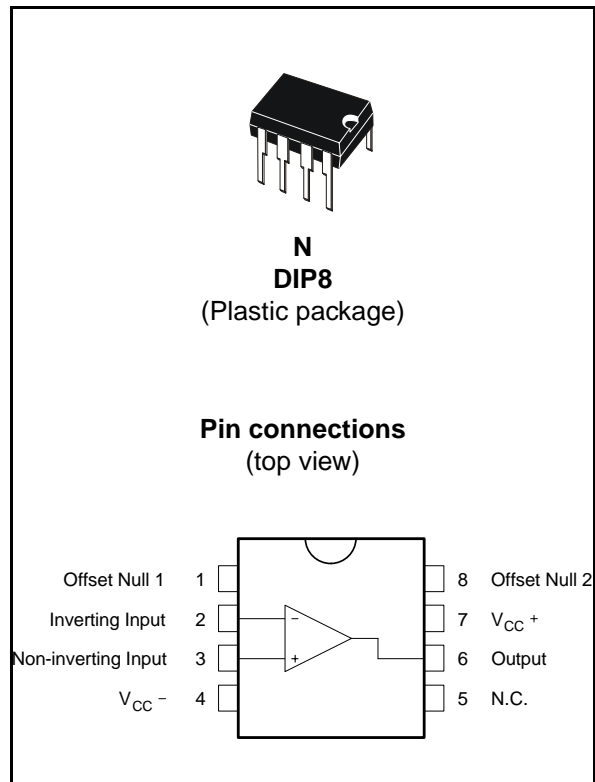

1 Schematic diagram

Figure 1. Schematic diagram

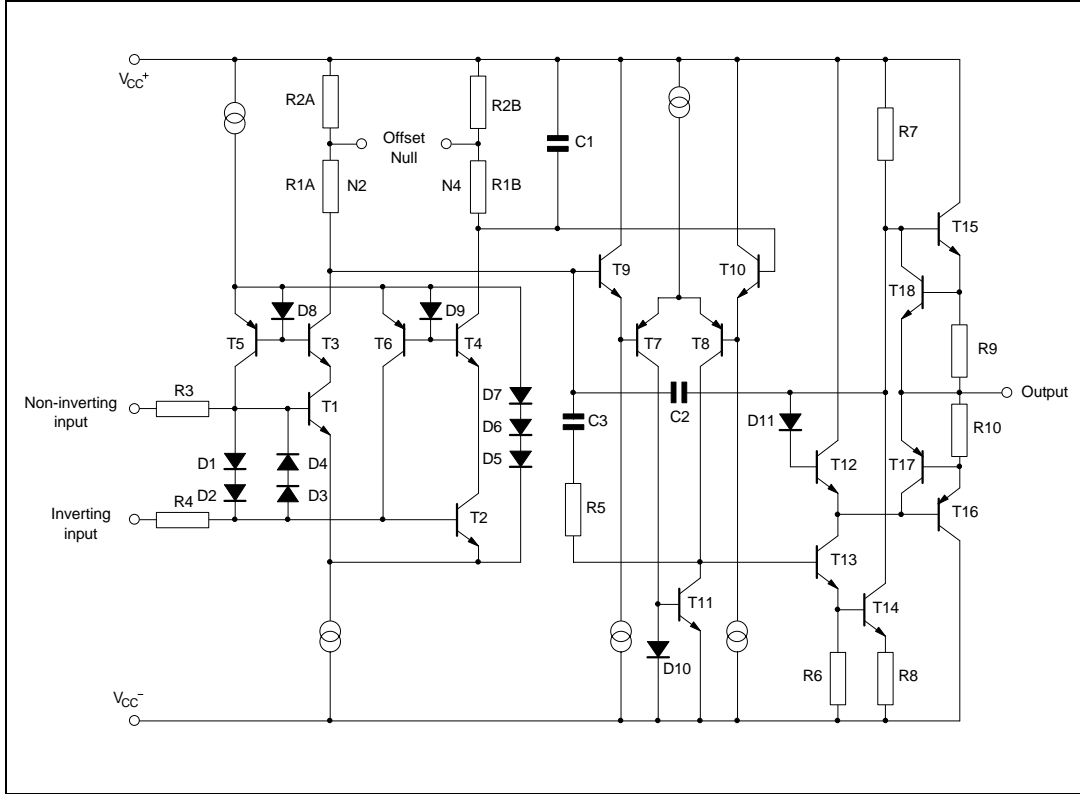
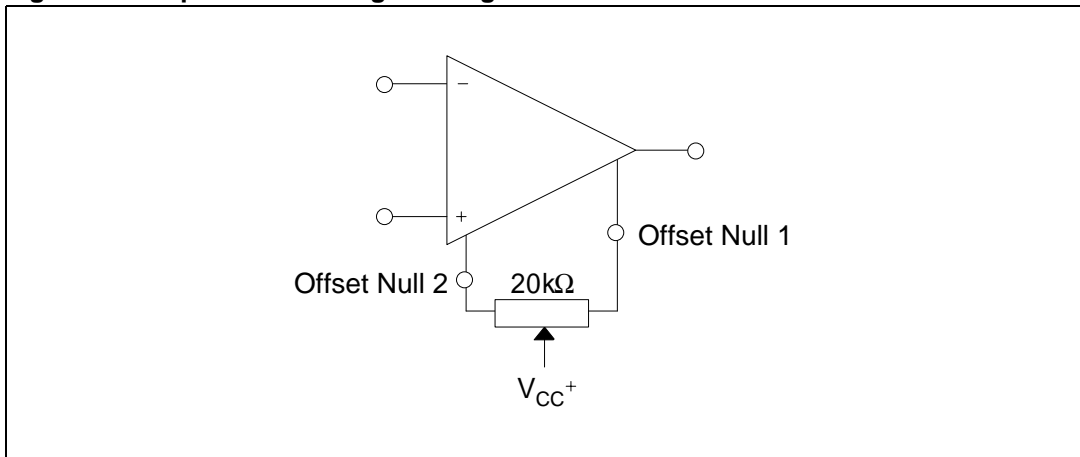

Figure 2. Input offset voltage nulling circuit



2 Absolute maximum ratings

Table 1. Absolute maximum ratings

Symbol	Parameter	Value	Unit
V _{CC}	Supply voltage	± 22	V
V _{id}	Differential input voltage	± 30	V
V _i	Input voltage	± 22	V
T _{oper}	Operating temperature	-40 to 105	°C
T _{stg}	Storage temperature	-65 to 150	°C
R _{thja}	Thermal resistance junction to ambient ^{(1) (2)} DIP8	85	°C/W
R _{thjc}	Thermal resistance junction to case ^{(1) (2)} DIP8	41	°C/W
ESD	HBM: human body model ⁽³⁾	1.5	kV
	MM: machine model ⁽⁴⁾	200	V
	CDM: charged device model ⁽⁵⁾	1.5	kV

1. Short-circuits can cause excessive heating and destructive dissipation.
2. R_{th} are typical values.
3. Human body model: 100pF discharged through a 1.5kΩ resistor between two pins of the device, done for all couples of pin combinations with other pins floating.
4. Machine model: a 200pF cap is charged to the specified voltage, then discharged directly between two pins of the device with no external series resistor (internal resistor < 5Ω). Done for all couples of pin combinations with other pins floating.
5. Charged device model: all pins plus package are charged together to the specified voltage and then discharged directly to the ground.

3 Electrical characteristics

Table 2. $V_{CC^+} = 15\text{ V}$, $V_{CC^-} = \text{Ground}$, $T_{\text{amb}} = 25^\circ\text{C}$ (unless otherwise specified)

Symbol	Parameter	Min.	Typ.	Max.	Unit
V_{io}	Input offset voltage $0^\circ\text{C} \leq T_{\text{amb}} \leq +105^\circ\text{C}$		60	150 250	μV
	Long term input offset - voltage stability ⁽¹⁾		0.4	2	$\mu\text{V}/\text{Mo}$
DV_{io}	Input offset voltage drift		0.5	1.8	$\mu\text{V}/^\circ\text{C}$
I_{io}	Input offset current ($V_{ic} = 0\text{V}$) $0^\circ\text{C} \leq T_{\text{amb}} \leq +105^\circ\text{C}$		0.8	6 7	nA
DI_{io}	Input offset current drift		15	50	$\text{pA}/^\circ\text{C}$
DI_{ib}	Input bias current drift		15	50	$\text{pA}/^\circ\text{C}$
R_o	Open loop output resistance		60		Ω
R_{id}	Differential input resistance		33		MW
R_{ic}	Common mode input resistance		120		GW
V_{icm}	Input common mode voltage range $0^\circ\text{C} \leq T_{\text{amb}} \leq +105^\circ\text{C}$	± 13 ± 13	± 13.5		V
CMR	Common-mode rejection ratio ($V_{ic} = V_{icm - \text{min}}$) $0^\circ\text{C} \leq T_{\text{amb}} \leq +105^\circ\text{C}$	100 97	120		dB
SVR	Supply voltage rejection ratio ($V_{CC} = \pm 3$ to $\pm 18\text{V}$) $0^\circ\text{C} \leq T_{\text{amb}} \leq +105^\circ\text{C}$	90 86	104		dB
A_{vd}	Large signal voltage gain $V_{CC} = \pm 15$, $R_L = 2\text{k}\Omega$, $V_O = \pm 10\text{V}$ $0^\circ\text{C} \leq T_{\text{amb}} \leq +105^\circ\text{C}$ $V_{CC} = \pm 3$, $R_L = 500\Omega$, $V_O = \pm 0.5\text{V}$	120 100 100	400		V/mV
V_{opp}	Output voltage swing $R_L = 10\text{k}\Omega$ $R_L = 2\text{k}\Omega$ $R_L = 1\text{k}\Omega$ $0^\circ\text{C} \leq T_{\text{amb}} \leq +105^\circ\text{C}$ $R_L = 2\text{k}\Omega$	± 12 ± 11.5 ± 11	± 13 ± 12.8 ± 12		V
SR	Slew rate ($R_L = 2\text{k}\Omega$, $C_L = 100\text{pF}$)		0.17		V/ μs
GBP	Gain bandwidth product ($R_L = 2\text{k}\Omega$, $C_L = 100\text{pF}$, $f = 100\text{kHz}$)		0.5		MHz
I_{CC}	Supply current - no load $0^\circ\text{C} \leq T_{\text{amb}} \leq +105^\circ\text{C}$ $V_{CC} = \pm 3\text{V}$		2.7 0.67	5 6 1.3	mA
e_n	Equivalent input noise voltage $f = 10\text{Hz}$ $f = 100\text{Hz}$ $f = 1\text{kHz}$		11 10.5 10	20 13.5 11.5	$\frac{\text{nV}}{\sqrt{\text{Hz}}}$
i_n	Equivalent input noise current $f = 10\text{Hz}$ $f = 100\text{Hz}$ $f = 1\text{kHz}$		0.3 0.2 0.1	0.9 0.3 0.2	$\frac{\text{pA}}{\sqrt{\text{Hz}}}$

1. Long term input offset voltage stability refers to the average trend line of V_{io} vs time over extended periods after the first 30 days of operation.