

■ Features :

- Universal AC input/Full range
- Low leakage current <100 μ A
- Protections: Short circuit / Overload / Over voltage
- Free air convection for rated power and 23.5CFM forced air convection for peak load
- ANSI/AAMI ES60601-1/IEC60601-1/EN60601-1 medical safety approved
- No load power consumption<0.75W
- Fixed switching frequency at 65KHz
- 3 years warranty



SPECIFICATION

MODEL	RPS-75-3.3	RPS-75-5	RPS-75-12	RPS-75-15	RPS-75-24	RPS-75-36	RPS-75-48	
OUTPUT	DC VOLTAGE	3.3V	5V	12V	15V	24V	36V	48V
	RATED CURRENT	15A	14A	6.3A	5A	3.2A	2.1A	1.6A
	CURRENT RANGE	0 ~ 20A	0 ~ 18.7A	0 ~ 8.3A	0 ~ 6.7A	0 ~ 4.2A	0 ~ 2.8A	0 ~ 2.1A
	RATED POWER	49.5W	70W	75.6W	75W	76.8W	75.6W	76.8W
	PEAK LOAD (23.5CFM)	66W	93.5W	99.6W	100.5W	100.8W	100.8W	100.8W
	RIPPLE & NOISE (max.) Note.2	80mVp-p	80mVp-p	120mVp-p	150mVp-p	240mVp-p	300mVp-p	300mVp-p
	VOLTAGE ADJ. RANGE	2.9 ~ 3.6V	4.75 ~ 5.5V	11.4 ~ 13.2V	13.5 ~ 16.5V	22.8 ~ 27.6V	34.2 ~ 39.6V	45.6 ~ 52.8V
	VOLTAGE TOLERANCE Note.3	$\pm 2.0\%$	$\pm 2.0\%$	$\pm 1.0\%$	$\pm 1.0\%$	$\pm 1.0\%$	$\pm 1.0\%$	$\pm 1.0\%$
	LINE REGULATION	$\pm 0.5\%$	$\pm 0.5\%$	$\pm 0.5\%$	$\pm 0.5\%$	$\pm 0.5\%$	$\pm 0.5\%$	$\pm 0.5\%$
	LOAD REGULATION	$\pm 1.5\%$	$\pm 1.5\%$	$\pm 1.0\%$	$\pm 1.0\%$	$\pm 1.0\%$	$\pm 1.0\%$	$\pm 1.0\%$
	SETUP, RISE TIME	500ms, 30ms/230VAC 500ms, 30ms/115VAC at full load						
HOLD UP TIME (Typ.)	80ms/230VAC 20ms/115VAC at full load							
INPUT	VOLTAGE RANGE	90 ~ 264VAC 127 ~ 370VDC						
	FREQUENCY RANGE	47 ~ 63Hz						
	EFFICIENCY(Typ.)	73%	78%	82%	83%	85%	86%	86%
	AC CURRENT (Typ.)	1.5A/115VAC 1A/230VAC						
	INRUSH CURRENT (Typ.)	COLD START 25A/115VAC 50A/230VAC						
LEAKAGE CURRENT Note.7	Earth leakage current < 100 μ A/264VAC , Touch leakage current < 100 μ A/264VAC							
PROTECTION	OVERLOAD	140 ~ 180% rated output power Protection type : Hiccup mode, recovers automatically after fault condition is removed.						
	OVER VOLTAGE	3.8 ~ 4.46V	5.75 ~ 6.75V	13.8 ~ 16.2V	17.25 ~ 20.25V	27.6 ~ 32.4V	41.4 ~ 48.6V	55.2 ~ 64.8V
ENVIRONMENT	WORKING TEMP.	-20 ~ +70 $^{\circ}$ C (Refer to "Derating Curve")						
	WORKING HUMIDITY	20 ~ 90% RH non-condensing						
	STORAGE TEMP., HUMIDITY	-40 ~ +85 $^{\circ}$ C, 10 ~ 95% RH						
	TEMP. COEFFICIENT	$\pm 0.03\%/^{\circ}$ C (0 ~ 45 $^{\circ}$ C)						
	VIBRATION	10 ~ 500Hz, 2G 10min./1cycle, period for 60min. each along X, Y, Z axes						
SAFETY & EMC (Note 4)	SAFETY STANDARDS	ANSI/AAMI ES60601-1, TUV EN60601-1, IEC60601-1 approved						
	WITHSTAND VOLTAGE	I/P-O/P:4KVAC I/P-FG:2KVAC O/P-FG:1.5KVAC						
	ISOLATION RESISTANCE	I/P-O/P, I/P-FG, O/P-FG:100M Ohms / 500VDC / 25 $^{\circ}$ C / 70% RH						
	EMC EMISSION	Compliance to EN55011 (CISPR11), EN55022 (CISPR22) Class B, EN61000-3-2,-3						
OTHERS	EMC IMMUNITY	Compliance to EN61000-4-2,3,4,5,6,8,11, EN55024, EN60601-1-2, EN61000-6-2, EN61204-3, heavy industry level, EN61204-3 medical level, criteria A						
	MTBF	446.8K hrs min. MIL-HDBK-217F (25 $^{\circ}$ C)						
	DIMENSION	127*76.2*31mm (L*W*H)						
NOTE	PACKING	0.26Kg; 63pcs/16.3Kg/1.35CUFT						
		<ol style="list-style-type: none"> 1. All parameters NOT specially mentioned are measured at 230VAC input, rated load and 25$^{\circ}$C of ambient temperature. 2. Ripple & noise are measured at 20MHz of bandwidth by using a 12" twisted pair-wire terminated with a 0.1uF & 47uF parallel capacitor. 3. Tolerance : includes set up tolerance, line regulation and load regulation. 4. The power supply is considered a component which will be installed into a final equipment. The final equipment must be re-confirmed that it still meets EMC directives. For guidance on how to perform these EMC tests, please refer to "EMI testing of component power supplies." (as available on http://www.meanwell.com) 5. Length of set up time is measured at cold first start. Turning ON/OFF the power supply may lead to increase of the set up time. 6. Heat Sink HS1,HS2,HS3 can not be shorted. 7. Touch current was measured from primary input to DC output. 						

Mechanical Specification

Unit:mm

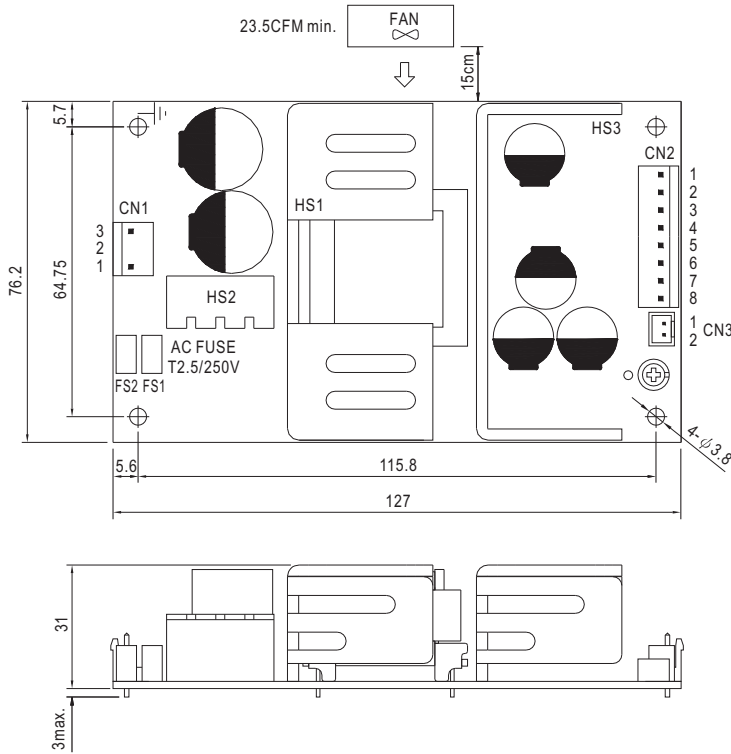

AC Input Connector (CN1) : JST B3P-VH or equivalent

Pin No.	Assignment	Mating Housing	Terminal
1	AC/N	JST VHR or equivalent	JST SVH-21T-P1.1 or equivalent
2	No Pin		
3	AC/L		

DC Output Connector (CN2) : JST B8P-VH or equivalent

Pin No.	Assignment	Mating Housing	Terminal
1,2,3,4	+V	JST VHR or equivalent	JST SVH-21T-P1.1 or equivalent
5,6,7,8	-V		

Remote Sense(CN3) : JST B2B-XH or equivalent

Pin No.	Assignment	Mating Housing	Terminal
1	RS+	JST XHP or equivalent	JST SXH-001T-P0.6 or equivalent
2	RS-		

⚠ HS1,HS2,HS3 can not be shorted

Block Diagram

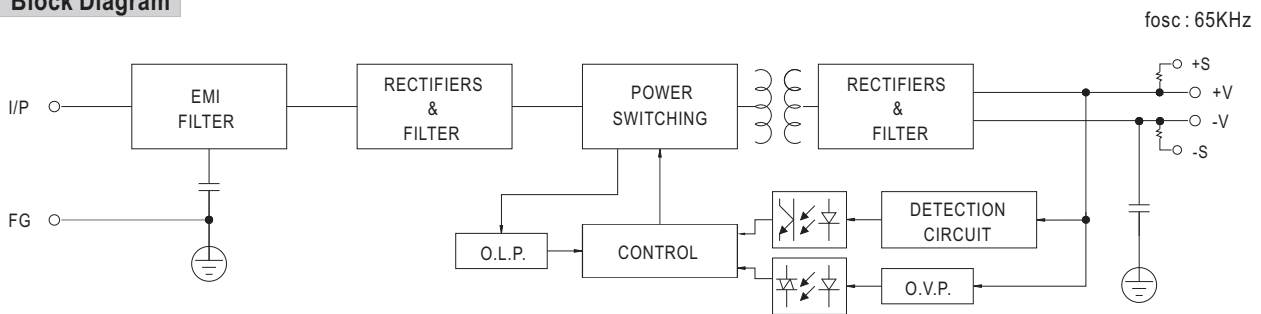

Derating Curve

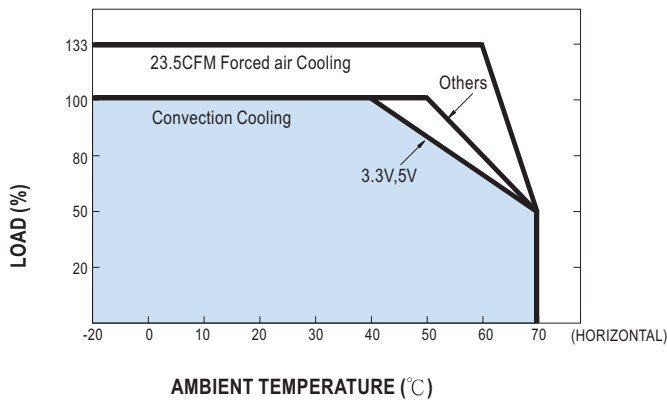

Output Derating VS Input Voltage

