

P	LTR	DESCRIPTION	DATE	DWN	APVD
C		REVISED PER ECR-25-247601	11OCT2025	PC	JH

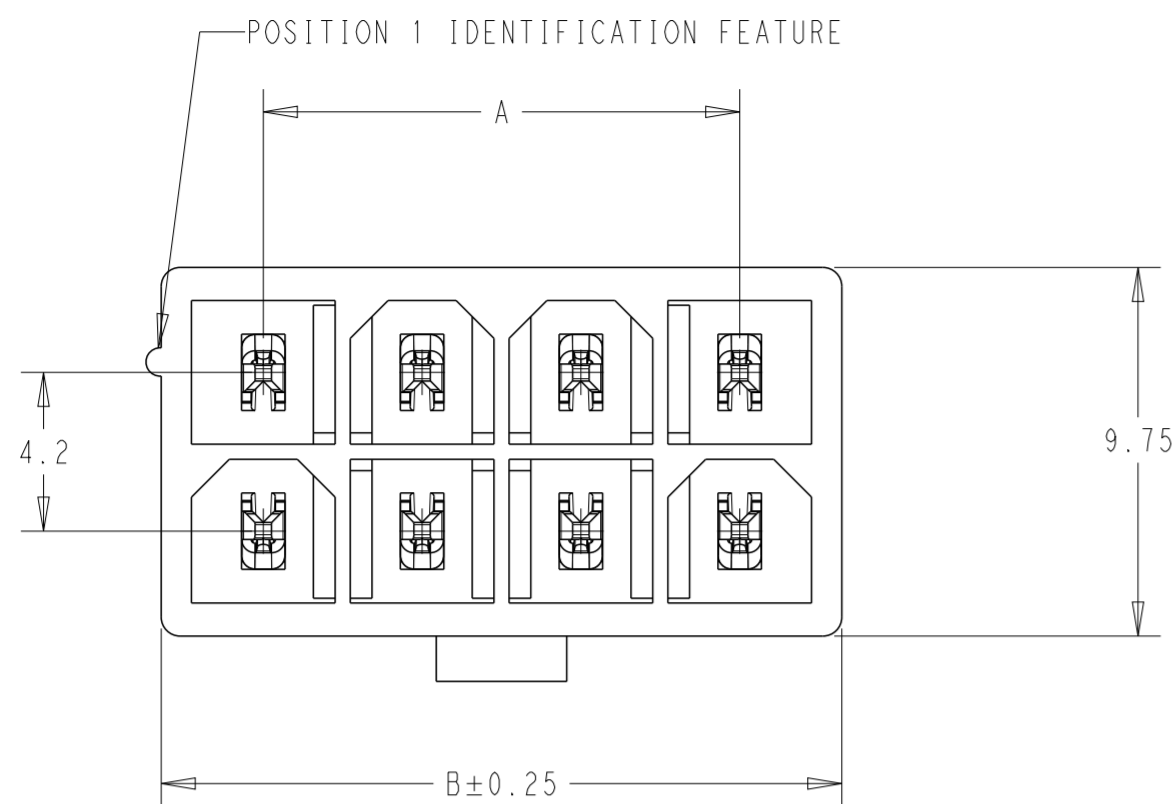

NOTES:

- 1 TYPE 1
- 2 TYPE 2
- 3 MATERIAL: HOUSING-NYLON, UL94V-2 (COLOR-NATURAL, COLOR OF PARTS MAY VARY) CONTACTS:0.25 THICK BRASS ALLOY
- 4 FINISH: CONTACT:UNDER PLATING NICKEL 15μ" MIN. BRIGHT TIN OVER 80μ" MIN.

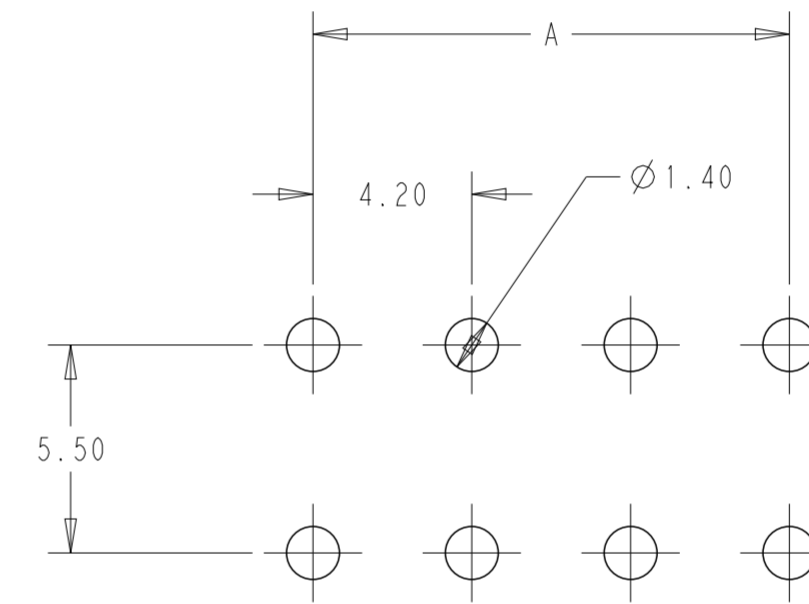
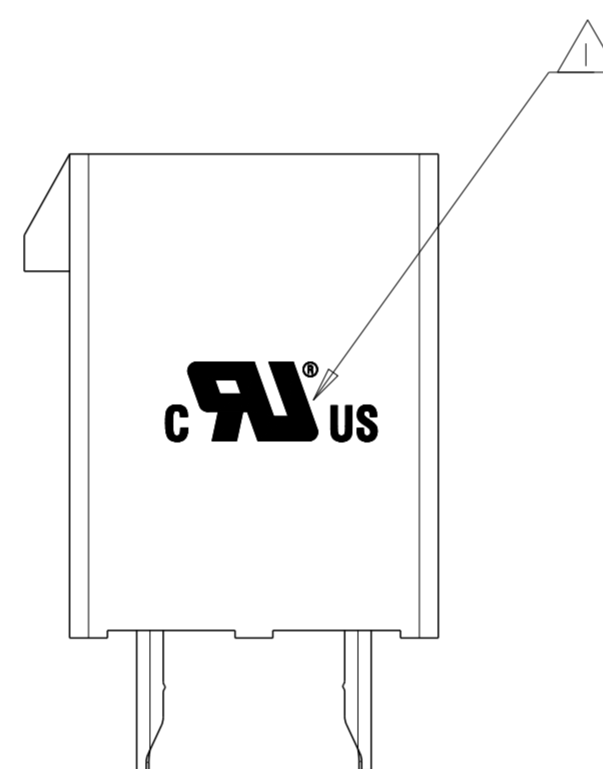
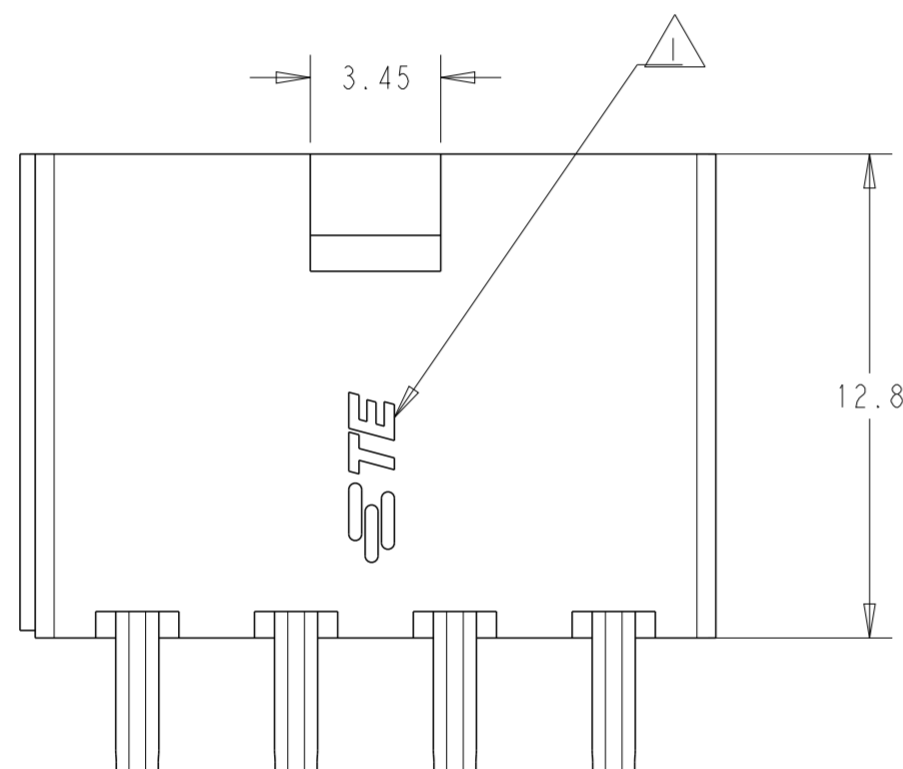

RECOMMENDED PCB LAYOUT (TOP VIEW)

TOLERANCES: ±0.05 (T=1.6)

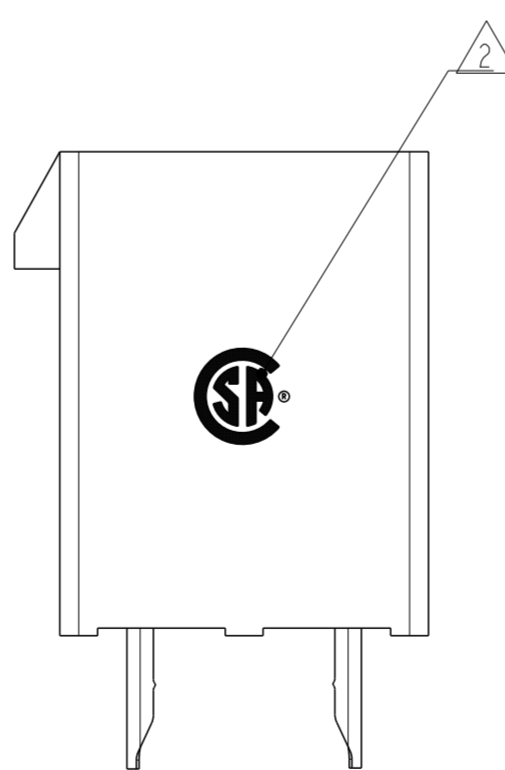
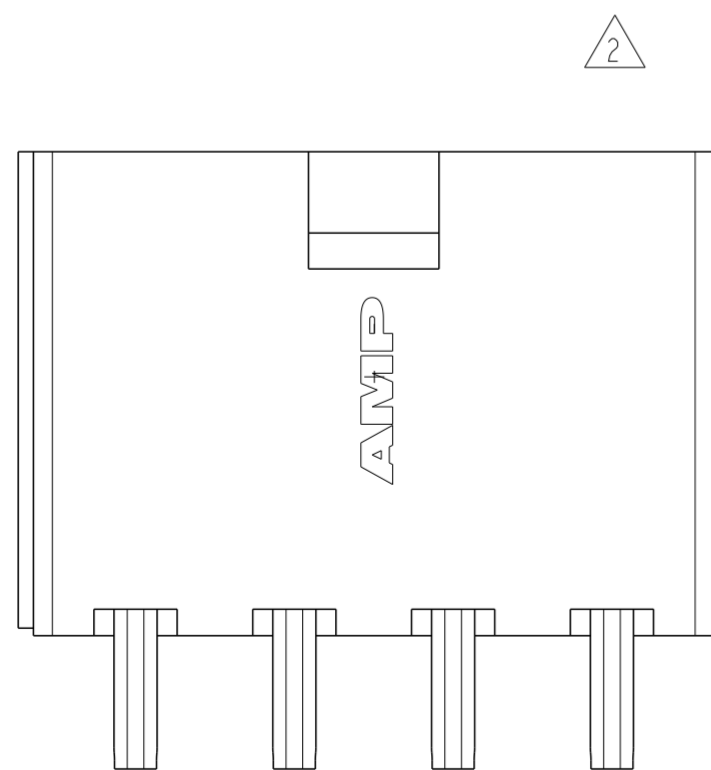

2	2-794954-4	51.6	46.2±0.25	24	2-1586037-4
2	2-794954-2	47.4	42.0±0.25	22	2-1586037-2
2	2-794954-0	43.2	37.8±0.25	20	2-1586037-0
2	1-794954-8	39.0	33.6±0.25	18	1-1586037-8
2	1-794954-6	34.8	29.4±0.25	16	1-1586037-6
2	1-794954-4	30.6	25.2±0.25	14	1-1586037-4
2	1-794954-2	26.4	21.0±0.25	12	1-1586037-2
2	1-794954-0	22.2	16.8±0.13	10	1-1586037-0
1	794954-8	18.0	12.6±0.13	8	1586037-8
1	794954-6	13.8	8.4±0.13	6	1586037-6
1	794954-4	9.6	4.2±0.13	4	1586037-4
1	794954-2	5.4		2	1586037-2

RECOMMENDED MATING REC HOUSING DIM B DIM A POSITION PART NUMBER

THIS DRAWING IS A CONTROLLED DOCUMENT.

DIMENSIONS: mm	TOLERANCES UNLESS OTHERWISE SPECIFIED: 0 PLC ±0.5 1 PLC ±0.25 2 PLC ±0.25 3 PLC ±0.25 4 PLC ±0.25 ANGLES ± FINISH ±	DWN P. CHEN 9-6-2025 CHK J. HUANG 11-6-2025 APVD J. HUANG 11-6-2025	TE Connectivity	
MATERIAL		PRODUCT SPEC 108-2112 APPLICATION SPEC 114-13172 WEIGHT	NAME Val-U-Lok V2 Header Assembly	
		CUSTOMER DRAWING	SIZE A2	RESTRICTED TO
			CAGE CODE 00779	
			DRAWING NO. C-1586037	
			SCALE 5:1	SHEET 1 OF 2
				REV C

4

3

2

1

© 2024 TE Connectivity. All Rights Reserved.

REVISIONS				
P	LTR	DESCRIPTION	DATE	APVD
-		SEE SHEET 1	-	-

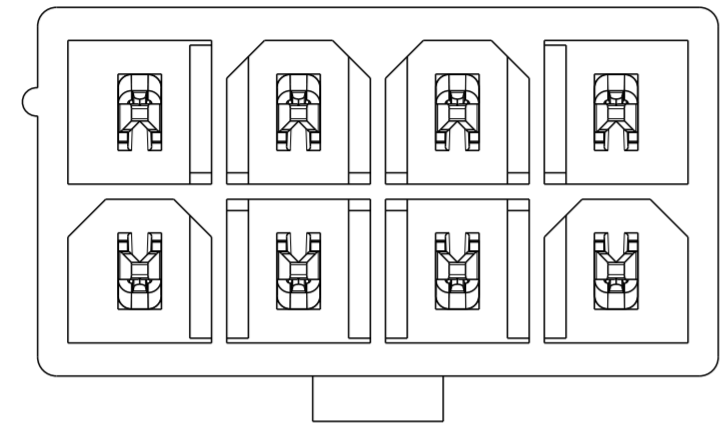

2\*4

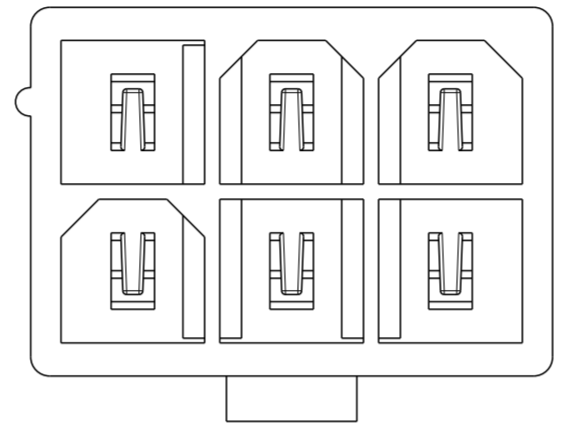

2\*3

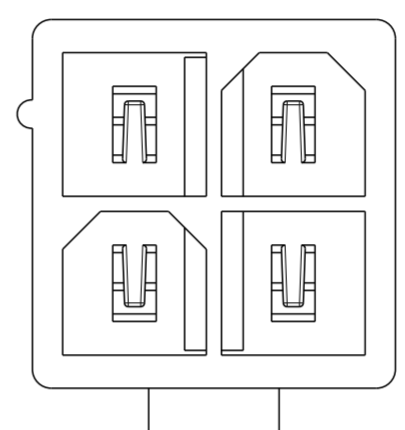

2\*2

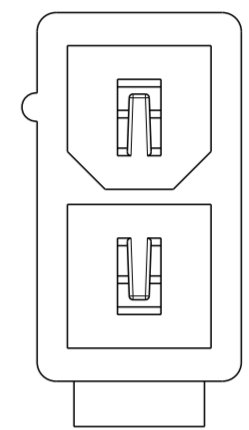

2\*1

THIS DRAWING IS A CONTROLLED DOCUMENT.		DWN P. CHEN 9-6-2025		
		CHK J. HUANG 11-6-2025		
DIMENSIONS: mm		TOLERANCES UNLESS OTHERWISE SPECIFIED:		NAME Val-U-Lok V2 Header Assembly
		0 PLC ± 1 PLC ±0.5 2 PLC ±0.25 3 PLC ± 4 PLC ± ANGLES ± FINISH ±		
MATERIAL	-	APVD J. HUANG 11-6-2025	PRODUCT SPEC 108-2112	RESTRICTED TO
	-	APPLICATION SPEC 114-13172	SCALE A2 00779 C-1586037	
	-	WEIGHT -	DRAWING NO C-1586037	
	-	CUSTOMER DRAWING	SCALE 5:1	SHEET 2 OF 2 REV C