

REV	CONTENT	CHK	DATE
V0.0	CONTENT	EXL	20.07.17

- NOTES:
- | | | |
|--|-----------------|----------------------|
| | UL | IEC |
| 1. Rated voltage/current : | 300V / 25A | 320V / 32A |
| 2. Torque Value: | M3, 4.4Lb.in | M3, 0.5N.m |
| 3. Wire range : | 26~10AWG | 0.2~4mm ² |
| 4. Stripping length : | 8mm | |
| 5. Withstanding voltage : | AC2500V / 1 Min | |
| 6. Operating temperature: | -40°C~+105°C | |
| 7. RoHS Compliance | | |
| 8. * "Is the key quality control point | | |

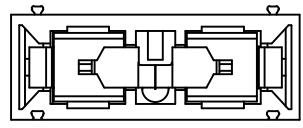
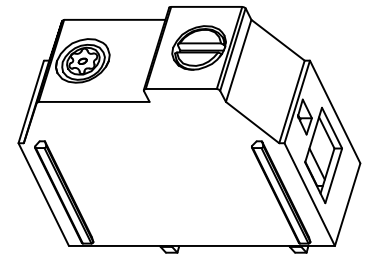
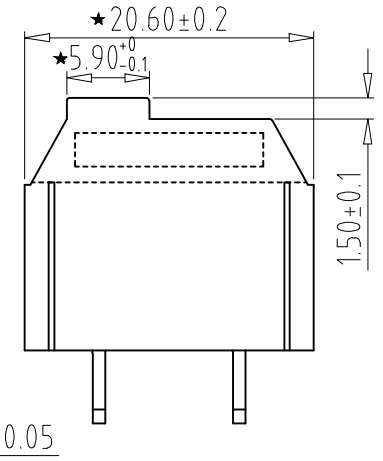
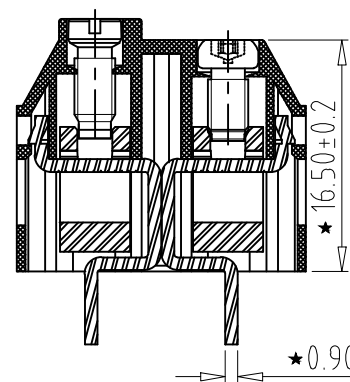
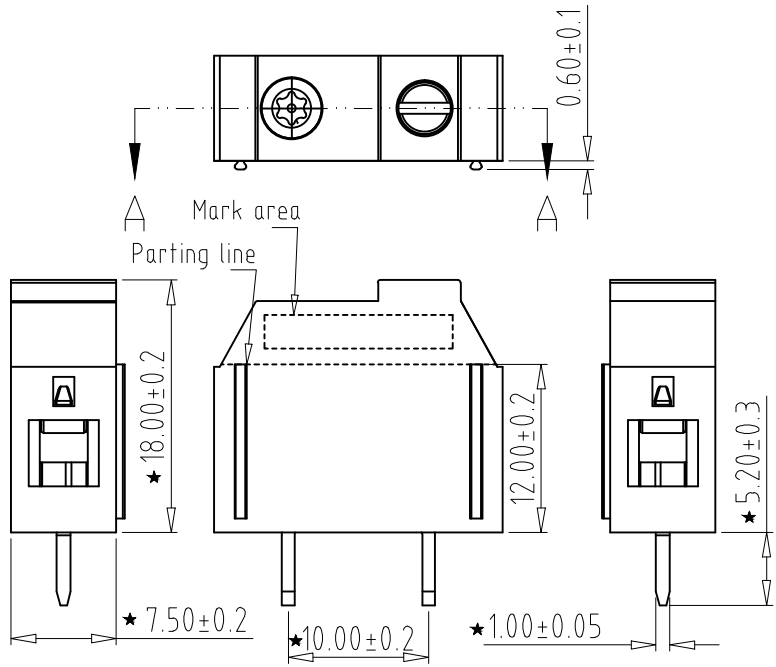

5	TORX SCREW	XX	1	Stainless steel	-
4	SCREW	XX	1	STEEL	Zn Plated
3	BLOCK	XX	2	BRASS	Ni Plated
2	PIN	XX	1	COPPER	Tin Plated
1	HOUSING	XX	1	PA66 UL94V-0	GREEN
ITEM	NAME OF PART	NO. OF PART	Q'TY	MATERIAL	NOTE
DWG.	CXL	DATE	20.06.26	SIZE	A4 UNITS mm SHEET/OF 1/1
CHK.	DATE		SCALE	1:1	
APP.	DATE				
NAME			GTPS4-7.5-01P-14-01		
NINGBO GOLTEN ELECTRONICS CO., LTD.			DWGNO. XXXX		

Total Pitch Tolerances in mm										Nominal dimension range in mm										⊥	≡	—	//				
over	over	over	over	over	over	over	over	over	over	over	over	over	over	over	over	over	over	over	over	over	over	over	over	all	over	over	over
0	30	53	70	90	115	150	250	350	500	0	30	53	70	90	115	150	200	250	320	0	10	10	10	to	to	to	150
±0.18	±0.20	±0.25	±0.3	±0.35	±0.4	±0.60	±0.70	±0.85	±0.20	±0.25	±0.30	±0.35	±0.4	±0.44	±0.55	±0.70	±0.80	±0.90	0.2	0.3	0.3	0.2	0.3	0.2	0.3	0.5	