PRODUCT SPECIFICATION

Commodity : 78mm 8W LED R7S

Model No : OLBZ.R8.0W-R7STL

For Customer Fill			
Confirmed Department :			
Confirmed Result :			
Signature :			
Finally Result :			

Prepared :	Engineering Department
Checked :	Engineering Department
Approved :	Engineering Department

● Applications

Widely used in offices,shopping malls,schools,hospitals,railway stations,libraries and other places.

● Features

1. Prime imported materials, efficient LEDs
2. Aluminum Alloy with even heat dissipation
3. PC fireproof 94-V0,no stroboscopic,no noise, non-glare, no UV radiation, environment-protected and comfortable
4. Quick response time, the LED response time is nanosecond.
5. High efficiency, energy-saving, long lifespan
6. Safe and strong, easy installation,widely used
7. No flicker, start quickly, soft light, protect your eyes.
8. Easy to install and use.
9. According to customer needs design intelligent sensor tube light,widely used in underground parking places.
10. 3 years warranty.

● Product Picture



● Size

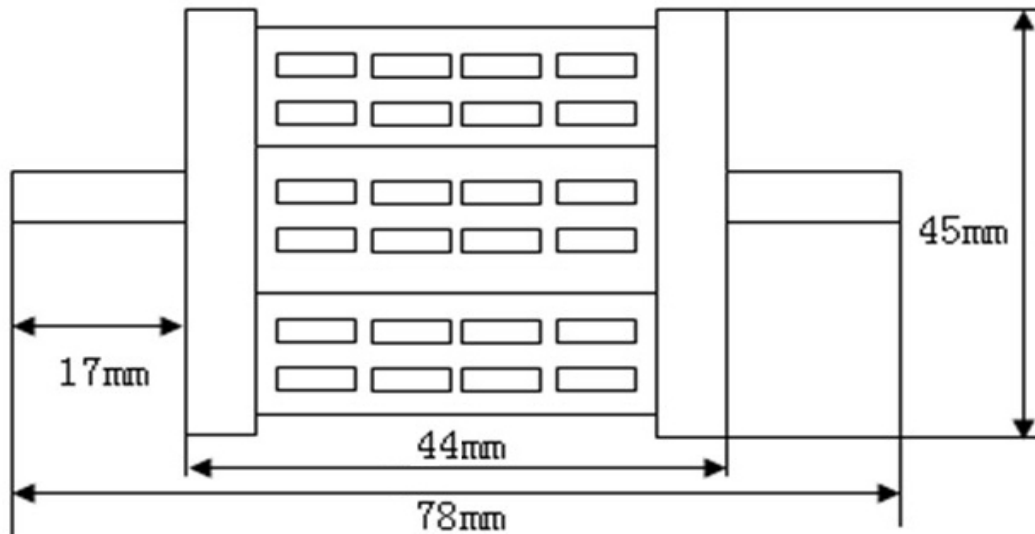

● Opto-electric Parameter

Power	8W
LED Type	Samsung 5630SMD
LED Quantity	24pcs
Input Voltage	85-265V ac
Frequency	50-60Hz
Luminous Flux	800Lm
Power Supply Efficiency	0.9
CCT	2700K-6500K
PF	>0.95
Luminous Efficiency	100Lm/Watts
CRI	80
Beam Angle	180°

● Environment & Mechanical Specification

Working Temperature	-25°~45°
Storage Temperature	-25°~60°
RH	<90%
Protection Rating	IP20
Lifespan	50000H
Size	78(L)x45(W)x40(H)mm

Net Weight	0.06Kg
Carton Dimension	480*330*350 mm 181pcs/carton

● Light Source Test Report

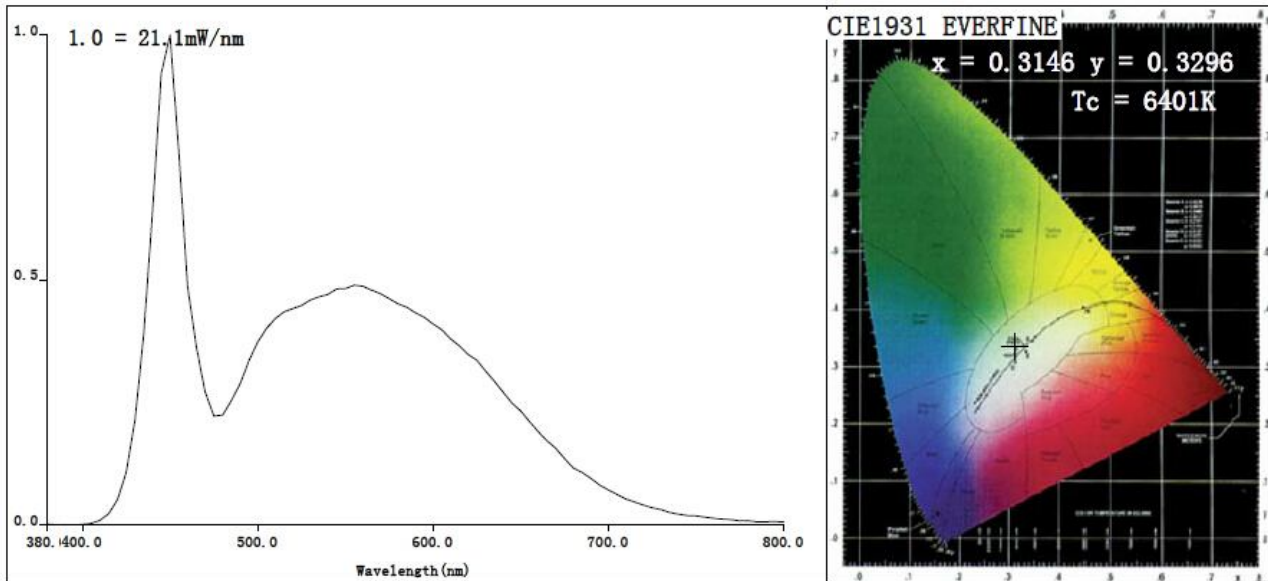

● Installation Instructions

1. When install or replace, please shut off power supply;
2. Installation or failure, professionals install or uninstall and maintenance
3. Please don't take apart or repack the products
4. Non-waterproof use only
5. Picture as bellows

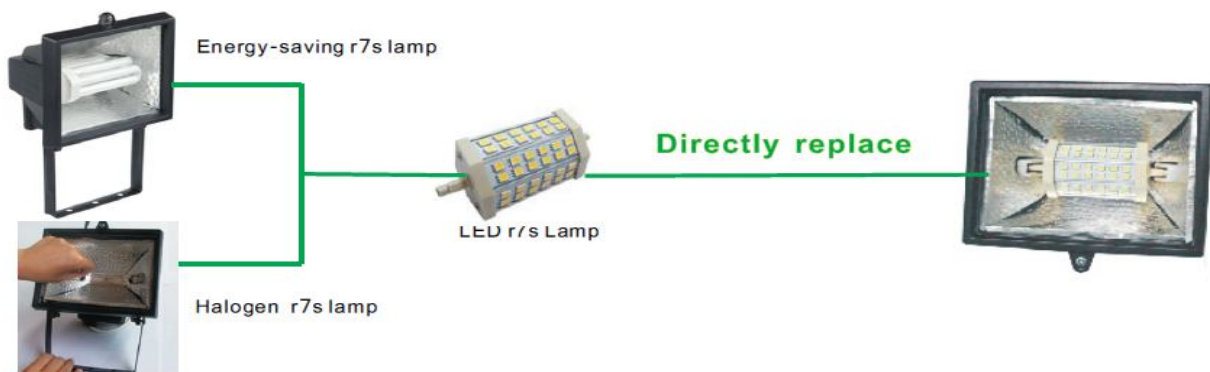

● Product Package

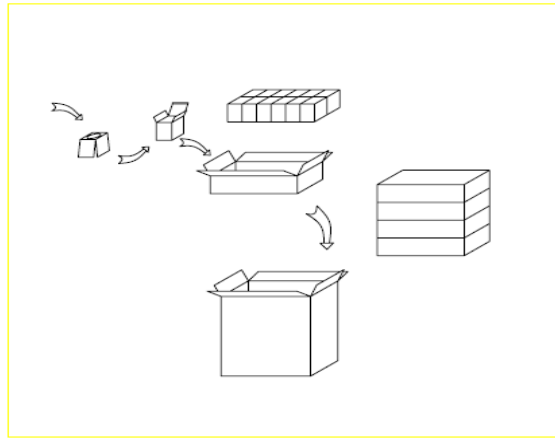

Inner packing size: 95(L)x60(W)x43(H)mm

Outer packing size: 480(L)x330(W)x350(H)mm 181PCS/Carton
16KG/Carton

● Storage

When product is not used, should put in packing, storage environment temperature and relative humidity should be accord with the requirement of product, there should be no corrosive gas of the warehouse or products, and no strong mechanical vibration, impact and role of strong magnetic fields. Packing should be at least 20cm high from the ground, don't let water immersion.

● Products Application Cases



The date listed in this file is for reference only, and the specific date should be subject to the specific products, if any change, sorry for no notice.