

**P/N: WTL2W11288**  
**SMD 12.5×4.6mm quartz crystal**



Customer	WTL
	Approved by: XoXo Lee
	Checked by: Susan He
	Issued by: Sheryl Xia

# SPECIFICATION

**维拓国际有限公司**

**WTL International Limited**

**Tel: 86-755-8267 7582 Fax: 86-755-8267 9302**  
**www.wtlcrystals.com email: wtl@wtlcrystals.com**

**P/N: WTL2W11288**  
**SMD 12.5×4.6mm quartz crystal**



## 1. ELECTRICAL SPECIFICATIONS

### 1.1 Specification

Parameter	Symbol	Min	Typ	Max	Units	Remark
Production type		Quartz Crystal Resonator				
Mode of oscillation		<b>1.Fundamental</b> 2.Third Overtone 3. 5th Overtone				
Frequency	FL	3.6864			MHz	
Load capacitance	CL	16			pF	
Frequency tolerance	Tol	±50			ppm	at 25°C±3°C
Equivalent resistance	Rs	150			Ω	Max
Working temperature range	TR	-40+85			°C	
Freq.Temp. Characteristics	TC	±50			ppm	Working temperature
Drive level	DL	100			μW	Max
Shunt capacitance	C0	5			pF	Max
Storage temperature range		-55+125			°C	
Insulation resistance		500			MΩ	Min
Measure Circuit		S&A 250B				TT network
Aging		5			ppm/Yr	Max
This product doesn't include harmful substance that stipulated by ROHS						

**P/N: WTL2W11288**  
**SMD 12.5×4.6mm quartz crystal**



**1.2 Dimension**

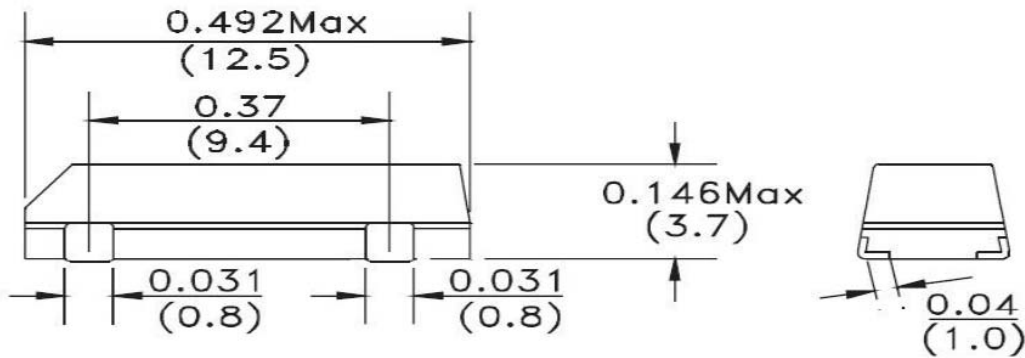
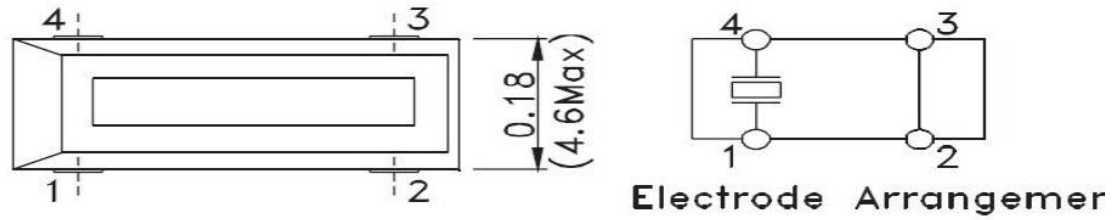

**1.3 Reflow**

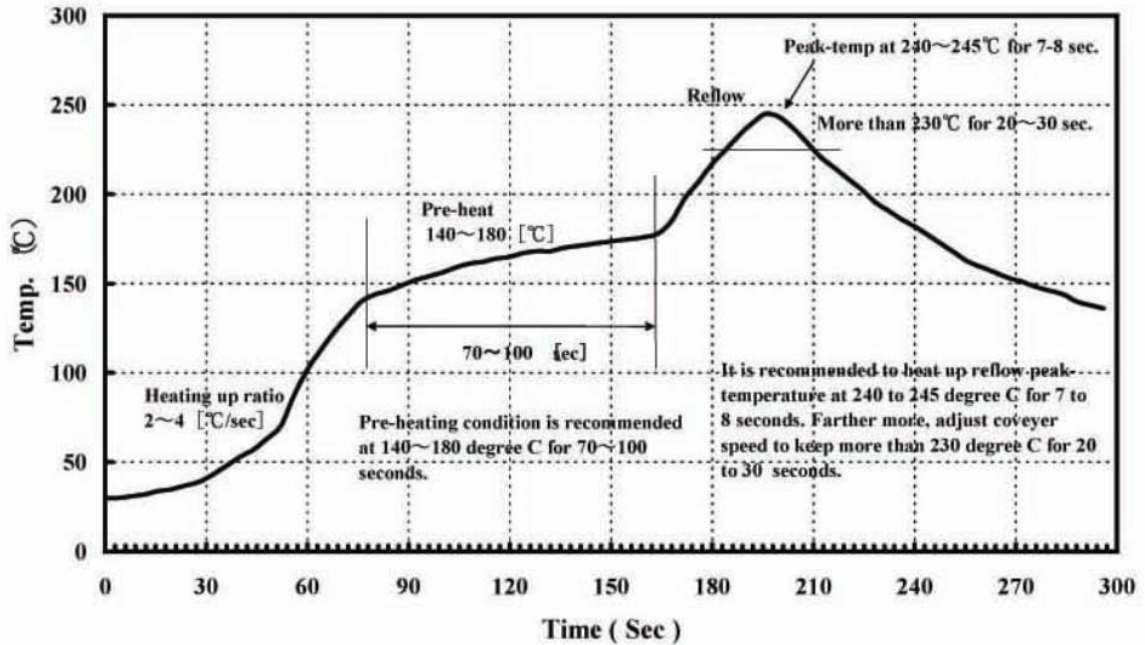

## 2. TEST STANDARD

### 2.1 GENERAL ELECTRICAL CHARACTERISTICS AND VISUAL TESTING

2.1.1 LOT CLASSIFICATION : If the quantity is 1,000 pcs or more, 1,000 pcs is one lot.

2.1.2 SAMPLING TEST METHOD : MIL-STD-105E G-II

2.1.3 TEST LEVEL

A] HIGH LEVEL DEFECT : AQL 0.065% [200 PCS]

B] MEDIUM LEVEL DEFECT : AQL 0.25% [50 PCS]

C] LOW LEVEL DEFECT : AQL 0.4% [32 PCS]

2.1.4 DEFECT CLASSIFICATION

A] HIGH LEVEL

@NO FREQUENCY

@MIXING

@LEAK DEFECT

B] MEDIUM LEVEL – ELECTRICAL CHARACTERISTIC DEFECT

@FREQUENCY

@OSCILLATION

@ELECTRICAL CURRENT

@OTHER ELECTRICAL CHARACTERISTICS DEFECT

C] VISUAL

@MARKING

@WELDING

@LEADS

@OTHER VISUAL DEFECT

TESTING METHOD AND ITS STANDARD CAN BE MODIFIED DEPENDING ON THE CUSTOMER'S REQUEST.

## 2.2 EQUIVALENT CIRCUITS

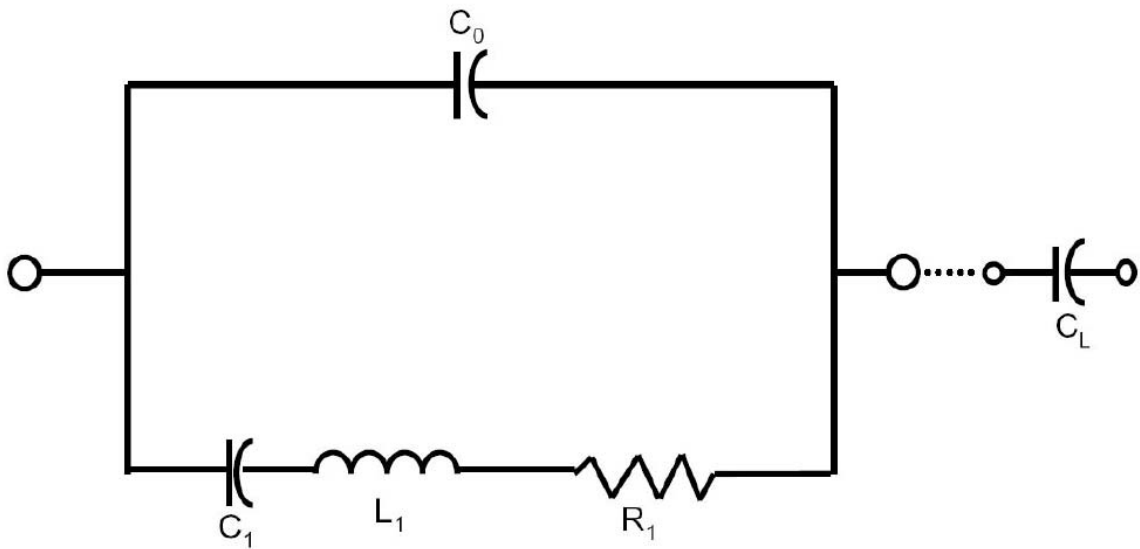
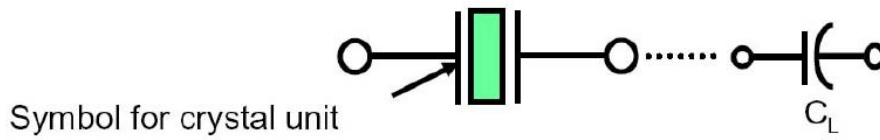

### 3. RELIABILITY TEST STANDARD

#### 3.1 ENVIRONMENTAL

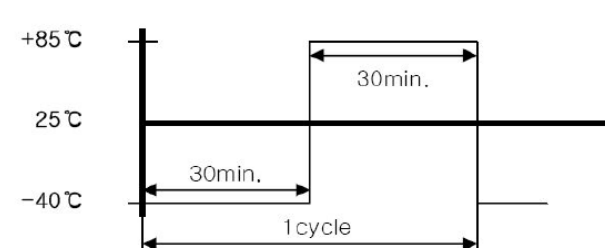
TEST ITEM	TESTING PROCEDURE & CONDITIONS	EVALUATION
1. THERMAL SHOCK TEST	<p>1. The test should be performed in accordance with the following condition for 10 cycle.</p>  <p>2. The crystal unit should be kept in room temperature for 1 hour then tested.</p>	The crystal unit should fulfill the specified requirements of the electrical characteristics and appearance.
2. HUMIDITY	<p>1. temperature : +40°C±2°C            RELATIVE HUMIDITY : 90~95%            TEST PERIOD : 48 HOURS</p> <p>2. The crystal unit should be kept in room temperature for 1 hour then tested.</p>	The crystal unit should fulfill the specified requirements of the electrical characteristics and appearance.
3. COLD TEMPERATURE TEST	<p>1. TEMPERATURE : -40°C±2°C            TEST PERIOD : 2 HOURS</p> <p>2. The crystal unit should be kept in room temperature for 1 hour then tested.</p>	The crystal unit should fulfill the specified requirements of the electrical characteristics and appearance.
4. THERMAL TEST	<p>1. TEMPERATURE : +85°C±2°C            TEST PERIOD : 24 HOURS</p> <p>2. The crystal unit should be kept in room temperature for 1 hour then tested.</p>	The crystal unit should fulfill the specified requirements of the electrical characteristics and appearance.
5. RAPID CHANGE IN TEMPERATURE	<p>1. TEMPERATURE : +85°C±2°C            TEST PERIOD : 120 HOURS</p> <p>2. The crystal unit should be kept in room temperature for 1 hour then tested.</p>	The crystal unit should fulfill the specified requirements of the electrical characteristics and appearance.

### 3.2 MECHANICAL

TEST ITEM	TESTING PROCEDURE & CONDITIONS	EVALUATION
1. LEAD TENSILITY	1. FIX THE UNIT. 2. APPLY 2LB OF WEIGHT AXIS TO THE LEADS. 3. TIME : 5 SECONDS	SHOULD PASS SEALING AND VISUAL TEST
2. LEAD BENDING	1. ATTACH 1 LB OF WEIGHT TO EACH OF THE LEADS. 2. BENDING ANGLE : 90° (FROM THE NORMAL POSITION TO 45° OPPOSITE DIRECTION) 3. BENDING TIME : 3 SECONDS(EACH DIRECTION) 4. NUMBER OF BENDING : 2 TIMES	SHOULD PASS SEALING AND VISUAL TEST
3. LEADS SOLDERABILITY	1. DIP THE LEADS INTO FLUX(ROJIN METHANOL) FOR 5 SECONDS 2. DIP THE LEADS INTO 250±5℃ 99% Sn DIPPING SOLUTION FOR 5 SECONDS.	THE DIPPED PART OF THE LEADS SHOULD HAVE 90~95% Sn COATING.
4. SOLDERING HEAT RESISTANCE TEST	1. PERFORM ELECTRICAL CHARACTERISTICS TEST BEFORE STARTING THIS PROCEDURE. 2. DIP THE LEADS INTO FLUX(ROJIN METHANOL) FOR 5 SECONDS. 3. DIP THE LEADS INTO 260±5℃ 99% Sn DIPPING SOLUTION FOR 5 SECONDS. 4. TAKE THE UNIT OUT, STORE AT ROOM TEMPERATURE FOR 30 SECONDS THEN MEASURE THE ELECTRICAL CHARACTERISTICS.	SHOULD PASS SEALING AND VISUAL TEST
5. VIBRATION	1. PERFORM ELECTRICAL CHARACTERISTICS TEST BEFORE STARTING THIS PROCEDURE. 2. THE UNIT SHOULD BE FIXED ONTO A VIBRATING MACHINE AND THEN SHAKEN X,Y,Z DIRECTIONS. VIBRATING FREQUENCY : 10 ~ 55 Hz AMPLITUDE : 0.03 Inch FACTOR TIME : 1 MINUTES TESTING TIME : 30 MINUTES EACH FOR X, Y, Z DIRECTIONS	SHOULD PASS SEALING AND VISUAL TEST
6. DROP TEST	1. PERFORM ELECTRICAL CHARACTERISTICS TEST BEFORE STARTING THIS PROCEDURE. 2. FROM THE HEIGHT OF 500mm DROP THE UNIT 3 TIMES ONTO A HARD RUBBER SURFACE.	SHOULD PASS SEALING AND VISUAL TEST
7. LEAK TEST	USE Helium Leak Detector. Bombing PRESSURE : 5kg/cm <sup>2</sup> Bombing TIME : 2 HOURS LEAK SHOULD BE LESS THAN 1E-8 atm.cc/sec.	GAS OR AIR SHOULD NOT BE DETECTED.
8. MARKING ERASE	SUBMERGE THE UNIT INTO IPA[ISOPROPYL ALCOHOL] SOLUTION FOR 10 MINUTES AND BRUSH THE MARKING 10 TIMES WITH A TOOTH BRUSH.	MARKING SHOULD NOT BE ERASED.

**4. Packing**

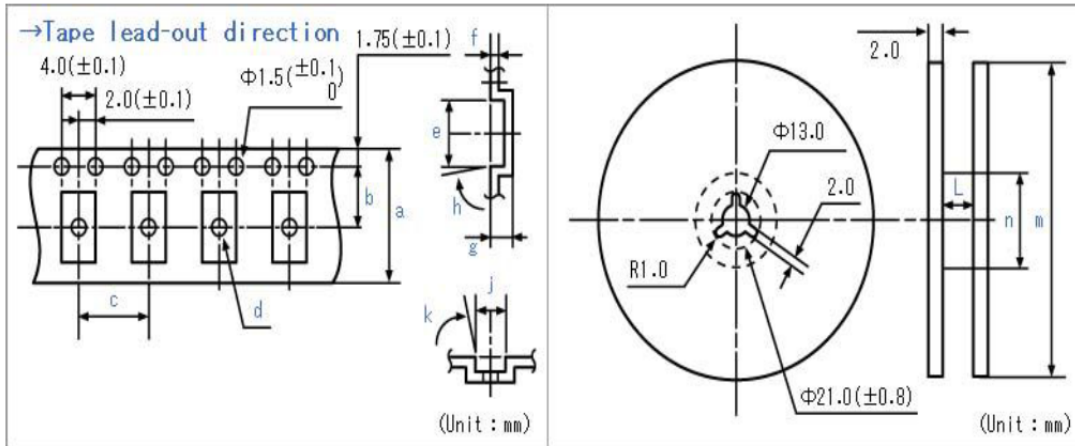

Quantity (pcs / reel)	a	b	c	d (Φ)	e	f	g	h (Max.)	j	k (Max.)	L	m (Φ)	n (Φ)
1,000	24.0	11.5	12.0	2.2	12.8	0.4	3.9	3°	4.8	3°	25.5	330	100

**4.2 PACKAGING METHOD**

4.2.1 TAPE & REEL AS SHOWN IN ABOVE DIMENSION,

4.2.2 INSERT 1,000 PCS OF TAPE & REEL COVERED WITH SHOCK ABSORBANT PAD INTO THE INNER BOX(INNER BOX SHOULD HAVE DESCRIPTION OF THE PART CONTAINED) AS SHOWN IN PICTURE1.

INNER-BOX CAN ACCOMODATE UPTO 1,000PCS.[PICTURE2]

4.2.3 INSERT SHOCK-ABSORBANT PAD ON ALL SIDES(INCLUDING TOP), AND THEN INSERT UPTO 5 INNER BOXES INTO THE OUTER BOX. [PICTURE3]

4.2.4 ON THE INNER-BOX COVER, LABEL CONTENTS OF THE BOX(FREQUENCY, LOAD CAPACITANCE, AND QUANTITY).

4.2.5 TO PREVENT INNER-BOX COVER OPENING DUE TO SHOCK, FASTEN THE COVER WITH A CLEAR TAPE AS SHOWN IN PICTURE4.



PICTURE1



PICTURE2



PICTURE3



PICTURE4



## 5. CAUTION

\* IN ORDER TO MAINTAIN QUALITY, WITHOUT CHANGE IN CHARACTERISTICS OF THE CRYSTAL UNITS, PLEASE FOLLOW BELOW RECOMMENDATION.

### 5.1 SHOCK

5.1.1 ALL CRYSTAL UNITS HAVE A THIN CRYSTAL BLANKS WITHIN. IF IT IS DROPPED ABOVE THE RECOMMENDED DROPPING HEIGHT( 500mm ), THE SPECIFIC CHARACTERISTICS AND APPEARANCE CAN BE CHANGED. PLEASE PAY SPECIAL ATTENTION TO EXTERNAL SHOCK.

### 5.2. ENVIRONMENTAL

5.2.1 CRYSTAL UNITS' FREQUENCY CAN BE CHANGED DUE TO SURROUNDING TEMPERATURE. IF IT IS STORED NEXT TO A HIGH TEMPERATURE HEATER (ABOVE+85℃) OR BELOW 40℃, AND A STRONG LIGHT SOURCE FOR LONG PERIOD OF TIME, THE ELECTRICAL CHARACTERISTICS CAN BE CHANGED. IT IS SUGGESTED THAT THESE ENVIROMENTS BE AVOIDED.

5.2.2 IF THE UNIT IS PLACED IN A HUMID ENVIRONMENT, LEAD TERMINAL CAN BE DAMAGED; THEREFORE, DO NOT STORE THE CRYSTAL UNITS IN A HUMID ENVIRONMENT.

5.2.3 CRYSTAL UNIT HAS VIBRATING CHARACTERISTICS. IF IT IS PLACED WHERE VIBRATION EXISTS, THE OPERATING CHARACTERISTICS CAN BE ALTERED; THEREFORE, THIS ENVIRONMENT SHOULD BE AVOIDED.

### 5.3 LEADS

5.3.1 IF THE LEADS ARE BENT 90° FROM ITS AXIS FOR MORE THAN 2 TIMES THE TERMINAL COULD BE DISCONNECTED; THEREFORE, DO NOT BENT THE LEADS EXCESSIVELY.

5.3.2 AFTER SOLDERING CRYSTAL UNITS INTO A PCB, IMPACTING THE UNIT FROM THE TOP, BOTTOM, LEFT OR RIGHT SIDE OF THE UNIT CAN SHATTER THE GLASS PORTION OF THE BASE, RENDERING THE UNIT USELESS.

### 5.4 ASSEMBLY METHOD

5.4.1 CORRECT ULTRASONIC FREQUENCY FOR CLEANING SHOULD BE LESS THAN 20KHz.

5.4.2 SOLDERING SHOULD BE DONE USING IEC 61760-1 OR Pb-Free Products.

### 5.5 STORAGE

5.5.1 IF THE CRYSTAL UNITS ARE STORED IN HUMID OR SALTY ENVIRONMENT, APPEARANCE CAN BE CHANGED AND SOLDERABILITY CAN DETERIORATE; THEREFORE, AVOID STORING IN SUCH ENVIRONMENT. DO NOT STORE THE CRYSTAL UNIT MORE THAN 3 MONTHS.