

SPECIFICATION

OF PRODUCTS

CUSTOMER : MICROS

PRODUCT NAME: DIELECTRIC ANTENNA ELEMENT

PART NUMBER : DAE1575R160640A

CUSTOMER P/N : ANT1575-1606A

Approved by	Checked by	Drawn by

Approval Sheet	
Customer	MICROS
Supplier P/N	DAE1575R160640A
Customer P/N	ANT1575-1606A

Customer's Approval Certificate	
Checked & Approved by	
Date	

Please return this copy as a certification of your approval.

1 SCOPE

This specification shall cover the characteristics of the dielectric antenna element with the type DAE1575R160640A .

2 PART NO.

PART NUMBER	CUSTOMER PART NO	SPECIFICATION NO
DAE1575R1606400A	ANT1575-1606A	

3 OUTLINE DRAWING AND DIMENSIONS

3.1 Appearance: No visible damage and dirt.

3.2 The products conform to the RoHS directive and national environment protection law.

3.3 Dimensions

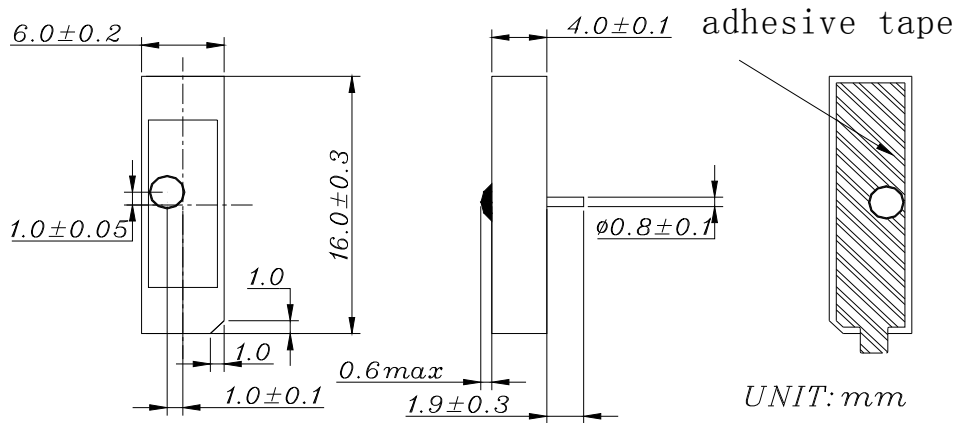

4 ELECTRICAL SPECIFICATIONS

4.1 Performance Characteristics

Items	Content
Nominal frequency	1575.42 ± 1.023 (MHz)
Center frequency (with adhesive tape on 22 square ground Plane)	1577.5 ± 2.5 (MHz)
-10dB Bandwidth min	5 (MHz)
VSWR at CF max	1.5
Polarization Model	Linear
Impedance	50 (Ω)
Frequency Temperature Coefficient max	20 (ppm/deg. $^{\circ}\text{C}$)

* Center frequency :-10dB bandwidth center frequency. depend on the ground plane of customers.

4.2 Return loss Characteristic

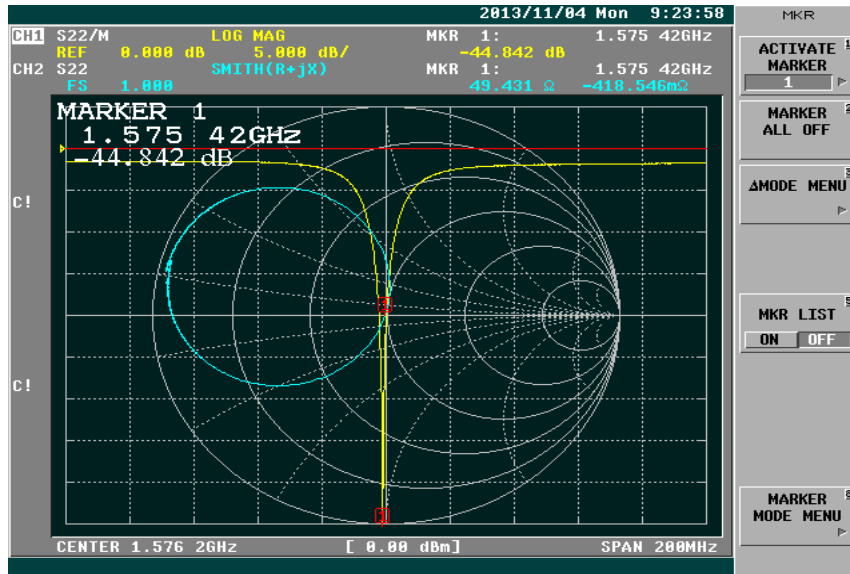

5 TEST

5.1 Test Conditions

Parts shall be measured under a condition (Temp.: $20^{\circ}\text{C} \pm 15^{\circ}\text{C}$, Humidity : $65\% \pm 20\%$ R.H.).

5.2 Test fixture

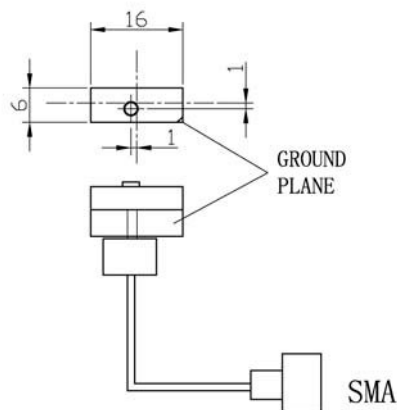

6 ENVIRONMENTAL TEST

No.	Item	Test Condition	Remark
6.1	Humidity Test	The device is subjected to 90%~95% relative humidity $60^{\circ}\text{C} \pm 3^{\circ}\text{C}$ for 96h~98h, then dry out at $25^{\circ}\text{C} \pm 5^{\circ}\text{C}$ and less than 65% relative humidity for 2h~4h. After dry out the device shall satisfy the specification in table 1.	It shall fulfill the specifications in Table 1.
6.2	High Temperature Exposure	The device shall satisfy the specification in table 1 after leaving at 105°C for 96h~98h, provided it would be measured after 2h~4h leaving in $25^{\circ}\text{C} \pm 5^{\circ}\text{C}$ and less than 65% relative	It shall fulfill the specifications in Table 1.

		humidity.	
6.3	Low Temperature	The device shall satisfy the specification in table 1 after leaving at -40°C for 96h~98h, provided it would be measured after 2h~4h leaving in 25°C ± 5 °C and less than 65% relative humidity.	It shall fulfill the specifications in Table 1.
6.4	Temperature Cycle	Subject the device to -40 °C for 30 min. followed by a high temperature of 105°C for 30 min cycling shall be repeated 5 times. At the room temperature for 1h prior to the measurement.	It shall fulfill the specifications in Table 1.
6.5	Vibration	Subject the device to vibration for 2h each in x、y and z axis with the amplitude of 1.5mm, the frequency shall be varied uniformly between the limits of 10Hz~55Hz.	It shall fulfill the specifications in Table 1.
6.6	Soldering Test	Lead terminals are heated up to 350°C ± 10 °C for 5s ± 0.5 s with brand iron and then element shall be measured after being placed in natural conditions for 1 h. No visible damage and it shall fulfill the specifications in Table 1	It shall fulfill the specifications in Table 1.
6.7	Solder ability	Lead terminals are immersed in soldering bath of 260°C~290°C for 3s ± 0.5s . More than 95% of the terminal surface of the device shall be covered with fresh solder.	The terminals shall be at least 95% covered by solder.
6.8	Terminal Pressure Strength	Force of 2kg is applied to each lead in axial direction for 10s ± 1 s (see drawing). No visible damage and it shall fulfill the specifications in Fig 1	Mechanical damage such as breaks shall not occur.

FIG 1

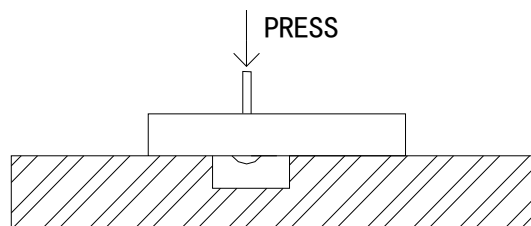

TABLE 1

Item	Specification After Test (MHz)
Center Frequency change	±2.0

-10dB Bandwidth Change	± 2.0
------------------------	-----------