



Hong Kong Caiqin Electronics Elements Co. Ltd

Address: Rm 16, Blk G, 2/F, Kwai Shing Ind Bldg, Phase 2, 42-46 Tai Lin Pai Rd, Kwai Chung, N.T., Hong Kong

Tel: (852) 2425 3926 Fax: (852) 2425 3240

E-mail address : sales@hkcandq.com ; sales@cai-qin.com

Web Site: <http://www.hkcandq.com>

APPROVAL SHEET

CUSTOMER P/N: _____

PART NAME: DIELECTRIC PATCH ANTENNA

SPECIFICATION : DA1575S25T2B

SUPPLIER: _____

DATE: _____

APPROVED BY :	CHECKED BY :	DRAWN BY :



1. ELECTRICAL SPECIFICATIONS

NO.	Part Number	Outline Dimension	Ground Plane
1-1	DA1575S25T2B	25*25*2mm	70x70mm
1-2	Center Frequency	1575±3MHz	
1-3	Bandwidth	15MHz min.	
1-4	Impedance	50Ω	
1-5	Gain @ Zenith	+4.0dBi typical	
1-6	Frequency Temperature Coefficient	0±10 ppm/°C	
1-7	Return Loss @fo	20dB min.	

2. STRUCTURE AND MATERIAL

No.	Description	Structure and material
2-1	Antenna Substrate	Dielectric Ceramics
2-2	Pin	Copper, lead and tin plate
2-3	Electrode	Ag plated
2-4	Ground Base	Ag plated

3. PHYSICAL DIMENSIONS

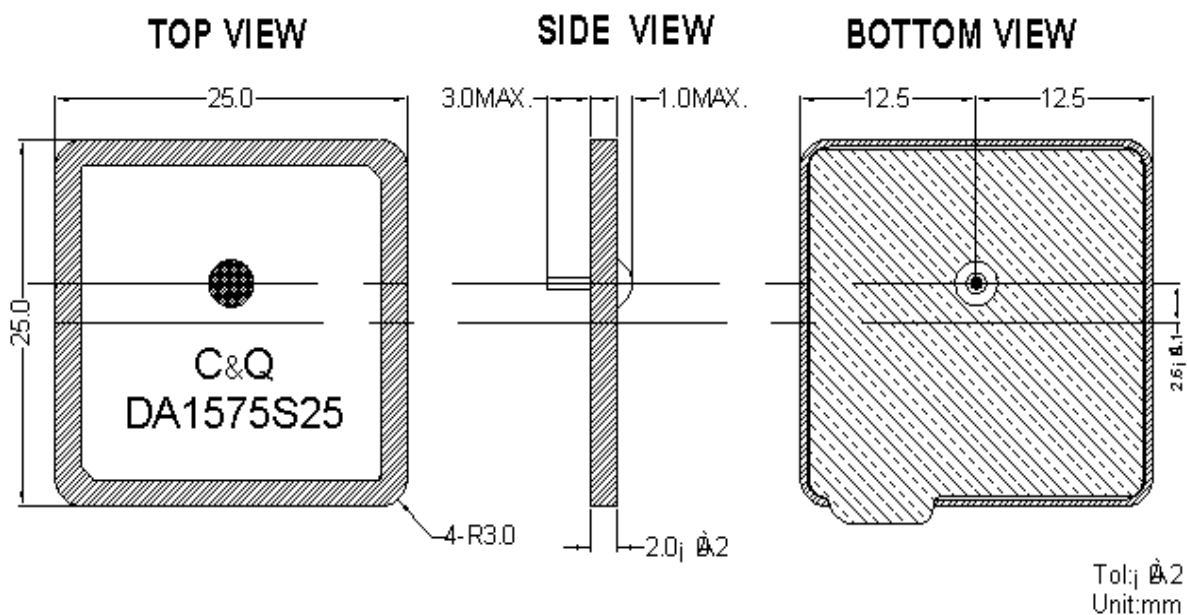

HONG KONG CAIQIN ELECTRONICS ELEMENTS CO., LTD

Address: Rm 16, Blk G, 2/F, Kwai Shing Ind Bldg, Phase 2, 42-46 Tai Lin Pai Rd, Kwai Chung, N.T., Hong Kong

Tel: (852) 2425 3926

Fax: (852) 2425 3240

E-mail address : sales@hkandq.com ; sales@cai-qin.com

Web Site: <http://www.hkandq.com>



4. ENVIRONMENTAL SPECIFICATIONS

Standard Condition : Temperature range: $25 \pm 3^{\circ}\text{C}$

Relative Humidity range: 55~75%RH

Operating Temperature range: $-40^{\circ}\text{C} \sim +85^{\circ}\text{C}$

Storage Temperature range: $-40^{\circ}\text{C} \sim +100^{\circ}\text{C}$

4.1 High Temperature Endurance

The device should satisfy the specification in Table 1 after exposed to temperature $85 \pm 5^{\circ}\text{C}$ for 24 ± 2 hours and 1~2 hours recovery time under normal temperature.

4.2 Low Temperature Endurance

The device should also satisfy the specification in Table 1 after exposed to the temperature $-40^{\circ}\text{C} \pm 5^{\circ}\text{C}$ for 24 ± 2 hours and 1~2 hours recovery time under normal temperature.

4.3 Moisture Proof

The device should satisfy the specification in Table 1 after exposed to the temperature $40 \pm 2^{\circ}\text{C}$ and the relative humidity 90~95% RH for 96 hours and 1~2 hours recovery time under normal condition.

4.4 Vibration Resist

The device should satisfy the specification in Table 1 after applied to the vibration of 10 to 55Hz with amplitude of 1.5mm for 2 hours each in X , Y and Z directions.

4.5 Drop Shock

The device should satisfy the specification in Table 1 after dropping onto the hard wooden board from the height of 30cm for 3 times each facet of the 3 dimensions of the device.

4.6 Temperature Cycle Test

The device should also satisfy the specification in Table 1 after exposed to the low temperature -25°C and high temperature $+85^{\circ}\text{C}$ for 30 ± 2 min each by 5 cycles and 1 to 2 hours recovery time under normal temperature.

HONG KONG CAIQIN ELECTRONICS ELEMENTS CO., LTD

Address: Rm 16, Blk G, 2/F, Kwai Shing Ind Bldg, Phase 2, 42-46 Tai Lin Pai Rd, Kwai Chung, N.T., Hong Kong Tel: (852) 2425 3926 Fax: (852) 2425 3240

E-mail address : sales@hkandq.com ; sales@cai-qin.com Web Site: <http://www.hkandq.com>