

SKB360 Bluetooth 4.0 Low Energy Module Datasheet

Name: Bluetooth 4.0 Low Energy Module

Model No.: SKB360

Version: V2.02

Revision History:

Revision	Description	Approved	Date
V1.01	Initial Release	Sunny	20140611
V2.01	Upgrade hardware	Sunny	20150117
V2.02	Added AT instruction	Sunny	20150528

Product Description

The SKB360 is a highly integrated Bluetooth 4.0 BLE module, designed for high data rate, short-range wireless communication in the 2.4GHz ISM band. The module is designed base on Nordic nRF51822 radio Transceiver IC, has a 32 bit ARM Cortex-M0 CPU, flash memory and analog and digital peripherals. The SKB360 provides a low power and ultra-low cost BLE solution for wireless transmission applications.

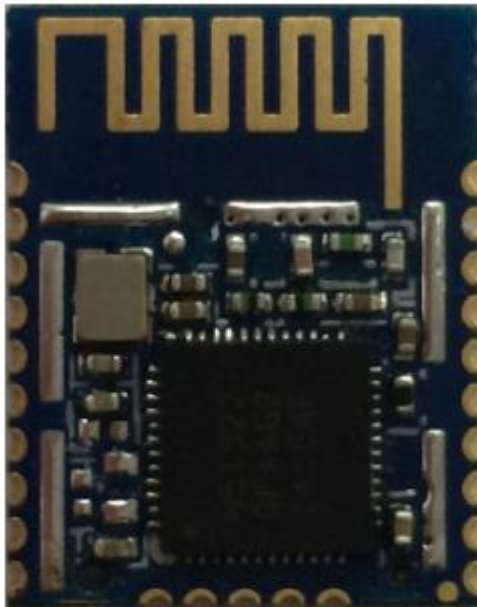

Figure 1: SKB360 Top View

Features

◆ Main Chip: nRF51822

◆ Bluetooth® 4.0 compliant low energy single-mode protocol stack

L2CAP, ATT, and SM protocols

GATT, GAP, and L2CAP

Peripheral and Broadcaster roles

GATT Client and Server

Full SMP support including MITM and OOB pairing

◆ 2.4 GHz transceiver

-93dBm sensitivity in Bluetooth low energy mode

250Kbps, 1Mbps, 2Mbps supported data rates

Tx Power -20 to +4 dBm in 4 dB steps

Tx Power -30 dBm Whisper mode

1.15mA peak RX, 1.3mA peak TX (+4dBm for 2.17Kbyte/s transmission rate)

RSSI (1 dB resolution)

◆ Flexible Power Management

Supply voltage range 1.8V to 3.6V

2.5us wake-up using 16MHz RCOSC

0.6uA@3V OFF mode

1.2uA@3V in OFF mode +1 region RAM retention

2.6uA@3V ON mode, all blocks IDLE

◆ 8/9/10 bit ADC-6 configurable channels

◆ 20 General Purpose I/O pins

◆ SPI Master/Slave

◆ Two-wire Master (I2C compatible)

◆ UART (CTS/RTS)

2.17K byte/s transmission rate (115200bps)

◆ CPU independent Programmable Peripheral Interconnect (PPI)

◆ Quadrature Decoder (QDEC)

◆ AES HW encryption

◆ Dimension: 17.4x13.7 x1.9 mm

Applications

◆ Computer peripherals and I/O devices

Mouse

Keyboard

Multi-touch trackpad

◆ Interactive entertainment devices

Remote control

3D Glasses

Gaming controller

◆ Personal Area Networks

Health/fitness sensor and monitor devices

Medical devices

Key-fobs + wrist watches

◆ Remote control toys

Pin Assignment

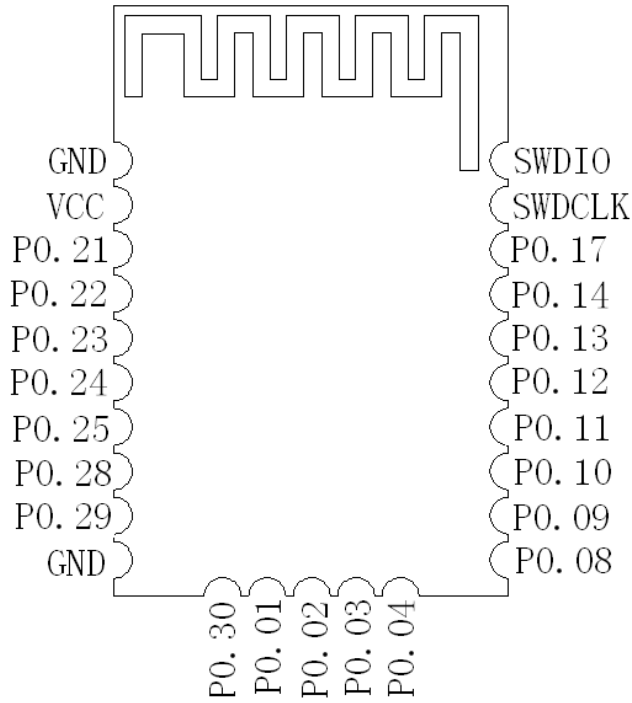

Figure 2: SKB360 Pin Package

Pin Description

Pin No.	Pin name	I/O	Description	Remark
1	GND	G	Ground	
2	VCC	P	Main power Supply	1.8V to 3.6V
3	P0.21	I/O	General Purpose I/O	
4	P0.22	I/O	General Purpose I/O	
5	P0.23	I/O	General Purpose I/O	
6	P0.24	I/O	General Purpose I/O	

7	P0.25	I/O	General Purpose I/O	
8	P0.28	I/O	General Purpose I/O	
9	P0.29	I/O	General Purpose I/O	
10	GND	G	Ground	
11	P0.30	I/O	General Purpose I/O	
12	P0.01	I/O	Digital I/O; Analog input	ADC/LPCOMP input 2
13	P0.02	I/O	Digital I/O; Analog input	ADC/LPCOMP input 3
14	P0.03	I/O	Digital I/O; Analog input	ADC/LPCOMP input 4
15	P0.04	I/O	Digital I/O; Analog input	ADC/LPCOMP input 5
16	P0.08	I/O	General Purpose I/O	Default UART TX
17	P0.09	I/O	General Purpose I/O	Default UART RX
18	P0.10	I/O	General Purpose I/O	
19	P0.11	I/O	General Purpose I/O	
20	P0.12	I/O	General Purpose I/O	
21	P0.13	I/O	General Purpose I/O	
22	P0.14	I/O	General Purpose I/O	
23	P0.17	I/O	General Purpose I/O	
24	SWCLK		Hardware debug ;Flash program I/O	
25	SWDIO		Hardware debug ;Flash program I/O	

Serial Peripheral Interface(SPI/SPIS)

The SPI interfaces enable full duplex synchronous communication between devices. They support a three-wire (SCK, MISO, MOSI) bi-directional bus with fast data transfers. The SPI Master can communicate with multiple slaves using individual chip select signals for each of the slave devices attached to a bus. Control of chip select signals is left to the application through use of GPIO signals. SPI Master has double buffered I/O data. The SPI Slave includes EasyDMA for data transfer directly to and from RAM allowing Slave data transfers to occur while the CPU is IDLE. The SPI peripheral support SPI mode 0,1,2,and 3. The module have 3 SPI ports and they properties like following table.

Instance	Master/Slave
SPI0	Master
SPI1	Master
SPIS1	Slave

Two-wire Interface(TWI)

The two-wire interface can communicate with a bi-directional wired-AND bus with two lines (SCL, SDA). The protocol makes it possible to interconnect up to 127 individually addressable devices. The interface is capable of clock stretching,

supporting data rates of 100 kbps and 400 kbps. The module have 2 TWI ports and they properties like following table.

Instance	Master/Slave
TWI0	Master
TWI1	Master

Universal Asynchronous Receiver/Transmitter (UART)

The Universal Asynchronous Receiver/Transmitter offers fast, full-duplex, asynchronous serial communication with built-in flow control (CTS, RTS) support in hardware up to 1 Mbps baud. Parity checking is supported.

The default P0.08 is UART_TX, P0.09 is UART_RX .Support the following baudrate in bps unit: 1200/2400/4800/9600/14400/19200/28800/38400/57600/76800/115200.

Special note: when communicating each other, the size of each packet is limited to 128 bytes. The time of sending the two data packets is more than 40ms, the typical value is 50ms. Otherwise the packet loss.

Notify: The GPIOs used for each SPI/TWI/UART interface line can be chosen from any GPIO on the device and are independently configurable.

UART AT Command

AT?	Get AT help message
AT+MAC	Get device MAC address.
AT+VER	Get software version message
AT+DEV_NAME	Set device advertise name
AT+PEER_NAME	Set the peer device name that want to connect
AT+CONNECT	Exit AT mode to start connecting with target peripheral
AT+SCAN_BLE	Scan the SKYLAB BLE_UART devices
AT+BAUD	Set UART's baudrate
AT+TXPWR	Set the radio's transmit power
AT+ADVINTVL	Set advertising interval time in ms unit
AT+STARTADV	Exit AT mode to start advertising
AT+RESET	Reset system by software
AT+SAVE	Save current configure paraments to flash
AT+FACTORY	Reply to factory Settings
AT+STATUS	Show device's current status
AT+SYSOFF	Go to system-off mode

Operating Conditions

The operating conditions are the physical parameters that the module can operate within as defined in table

Parameter	Symbol	Min.	Typ.	Max.	Units
Supply voltage, normal mode	VCC	1.8	3.0	3.6	V
Supply rise time (0V to 1.8V)	Tr_vcc			60	ms
Operating temperature	Ta	-25	25	75	°C

General Purpose I/O(GPIO) specifications

Parameter	Symbol	Min.	Typ.	Max.	Units
Input high voltage	V _{IH}	0.7VDD		VDD	V
Input low voltage	V _{IL}	V _{SS}		0.3VDD	V
Output high voltage	V _{OH}	VDD-0.3		VDD	V
Output low voltage	V _{OL}	V _{SS}		0.3VDD	V
Pull-up resistance	R _{PU}	11	13	16	k Ω
Pull-down resistance	P _{PD}	11	13	16	k Ω

Absolute Maximum Rating

Maximum ratings are the extreme limits the module can be exposed to without causing permanent damage. Exposure to absolute maximum ratings for prolonged periods of time may affect the reliability of the module.

Parameter	Symbol	Min	Max	Units
Power Supply				
Power Supply Volt.	VCC	-0.3	+3.9	V
Input Pins				
Input voltage on any input connection	V _{IO}	-0.3	VCC+0.3	V
Human Body Model	ESD HBM		4000	V
Charged Device Model	ESD CDM		750	V
Environment				
Storage Temperature	T _{stg}	-40	+125	°C
Flash memory Endurance	Write/erase		20000	times
Number of times an address can be written between erase cycles			2	times

Recommend Layout

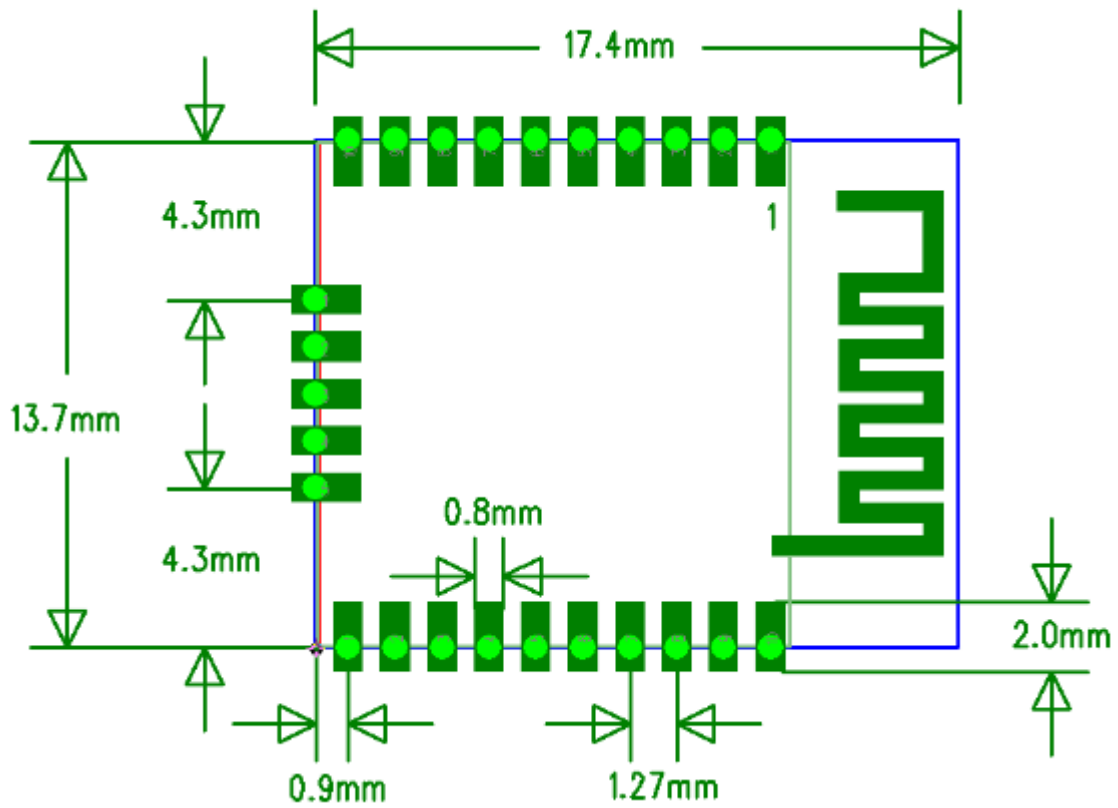

Manufacturing Process Recommendations

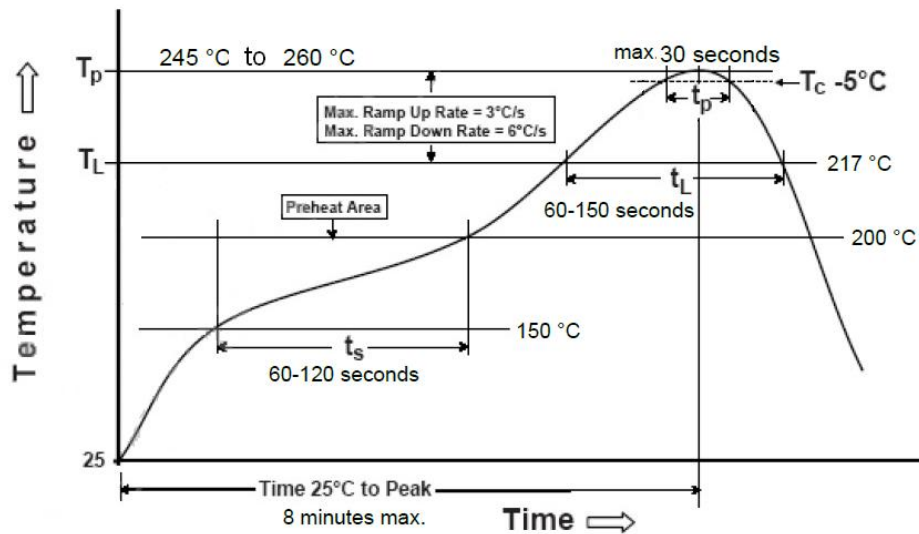

Figure 3: SKB360 Typical Leadfree Soldering Profile

Note: The final soldering temperature chosen at the factory depends on additional external factors like choice of soldering paste, size, thickness and properties of the baseboard, etc. Exceeding the maximum soldering temperature in the recommended soldering profile may permanently damage the module.

Packaging Specification

SKB360 modules are shipped in reel and with 1000 units per reel. Each tray is ‘dry’ package.

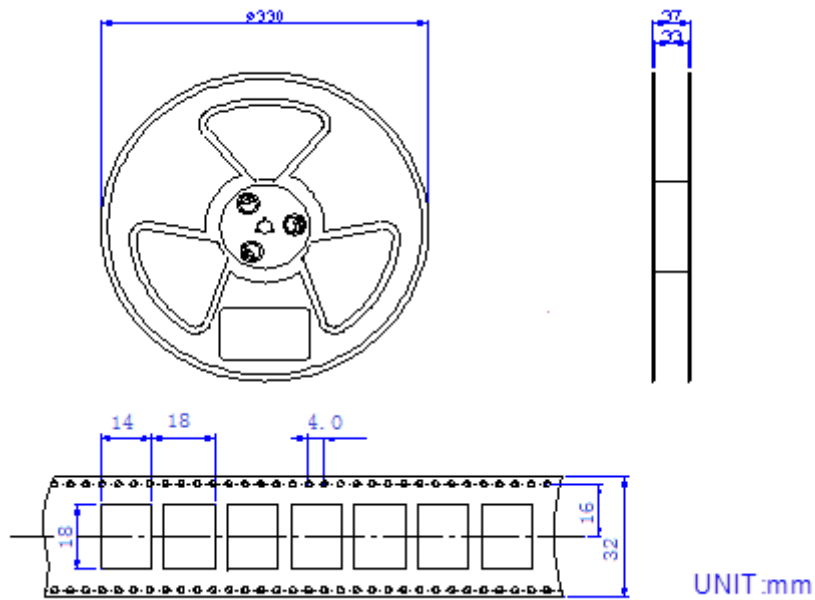

Figure 6: SKB360 Packaging

Skylab M&C Technology Co., Ltd.

Address: 9th Floor, Zhongguang Building, Yayuan Road, Bantian, Shenzhen

Phone: 86-755 8340 8210 (Sales Support)

Phone: 86-755 8340 8130 (Technical Support)

Fax: 86-755-8340 8560

E-Mail: sales1@skylab.com.cn

Website: www.skylab.com.cn