

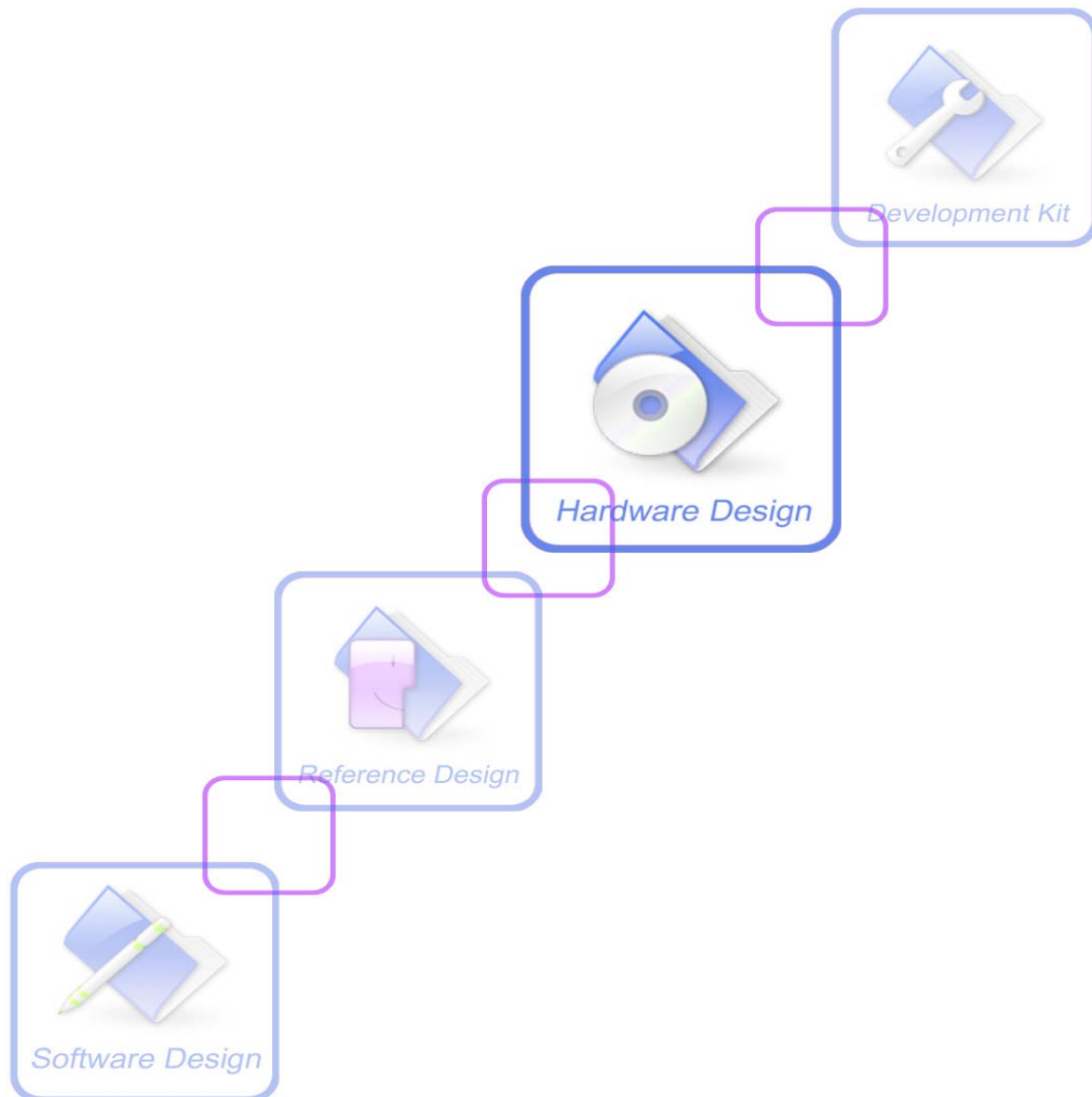

Hardware Design

SIM900B_HD_V1.04



Document Title:	SIM900B Hardware Design
Version:	1.04
Date:	2010-08-19
Status:	Release
Document Control ID:	SIM900B_HD_V1.04

General Notes

SIMCom offers this information as a service to its customers, to support application and engineering efforts that use the products designed by SIMCom. The information provided is based upon requirements specifically provided to SIMCom by the customers. SIMCom has not undertaken any independent search for additional relevant information, including any information that may be in the customer's possession. Furthermore, system validation of this product designed by SIMCom within a larger electronic system remains the responsibility of the customer or the customer's system integrator. All specifications supplied herein are subject to change.

Copyright

This document contains proprietary technical information which is the property of SIMCom Limited, copying of this document and giving it to others and the using or communication of the contents thereof, are forbidden without express authority. Offenders are liable to the payment of damages. All rights reserved in the event of grant of a patent or the registration of a utility model or design. All specification supplied herein are subject to change without notice at any time.

Copyright © Shanghai SIMCom Wireless Solutions Ltd. 2010

Contents

Contents	3
Version history	7
1 Introduction	8
1.1 Related Documents	8
1.2 Terms and Abbreviations	8
1.3 Safety Caution	11
2 SIM900B Overview	13
2.1 SIM900B Key Features	13
2.2 SIM900B Functional Diagram	15
2.3 SIM900B Evaluation Board	16
3 Application Interface	18
3.1 SIM900B Pin Description	18
3.2 Operating Modes	21
3.3 Power Supply	22
3.3.1 Power Supply Pins	23
3.3.2 Minimizing Power Losses	24
3.3.3 Monitoring Power Supply	24
3.4 Power Up and Power Down Scenarios	24
3.4.1 Turn On SIM900B	24
3.4.2 Turn Off SIM900B	26
3.4.3 Restart SIM900B Using the PWRKEY Pin	28
3.5 Power Saving	29
3.5.1 Minimum Functionality Mode	29
3.5.2 Sleep Mode (CSCLK=1) (Slow Clock Mode)	29
3.5.3 Wake Up SIM900B from SLEEP Mode(CSCLK=1)	30
3.5.4 Sleep Mode(CSCLK=2) (Slow Clock Mode)	30
3.5.5 Wake Up SIM900B from SLEEP Mode(CSCLK=2)	30
3.6 RTC Backup	30
3.7 Serial Interfaces	32
3.7.1 Function of serial port & debug port supporting	33
3.7.2 Software Upgrade and Software Debug	34
3.8 Audio Interfaces	36
3.8.1 Speaker Interface Configuration	37
3.8.2 Microphone Interfaces Configuration	38
3.8.3 Earphone Interface Configuration	38
3.8.4 Referenced Electronic Characteristic	39
3.9 Buzzer	40
3.10 SIM Card Interface	41
3.10.1 SIM Card Application	41

3.10.2 Design Considerations for SIM Card Holder	42
3.11 LCD Display Interface	45
3.12 Keypad Interface	45
3.13 ADC	46
3.14 Behaviors of the RI	47
3.15 Network Status Indication	48
3.16 General Purpose Input Output (GPIO)	49
4 Antenna Interface	50
4.1 Module RF Output Power	51
4.2 Module RF Receive Sensitivity	51
4.3 Module Operating Frequencies	51
5 Electrical, Reliability and Radio Characteristics	51
5.1 Absolute Maximum Ratings	51
5.2 Operating Temperatures	52
5.3 Power Supply Ratings	52
5.4 Current Consumption	53
5.5 Electro-Static Discharge	54
6 Mechanics	56
6.1 Mechanical Dimensions of SIM900B	56
6.2 Top View of the SIM900B	57
6.3 Mounting SIM900B onto the application platform	58
6.4 Board-to-board connector	58
6.4.1 Mechanical dimensions of the RUNFENG BB530-06001-20R	58
6.5 RF connector	60
6.6 PIN Assignment of SIM900B	62

Table Index

TABLE 1: RELATED DOCUMENTS	8
TABLE 2: TERMS AND ABBREVIATIONS	9
TABLE 3: SIM900B KEY FEATURES	13
TABLE 4: CODING SCHEMES AND MAXIMUM DATA RATES OVER AIR INTERFACE.....	15
TABLE 5: PIN DESCRIPTION	18
TABLE 6: OVERVIEW OF OPERATING MODES.....	21
TABLE 7: THE CURRENT CONSUMPTION OF DIFFERENT CONFIGURATION OF AT+CFUN.....	29
TABLE 8: PIN DEFINITION OF THE SERIAL INTERFACES	32
TABLE 9: LOGIC LEVELS OF THE SERIAL PORT AND DEBUG PORT	33
TABLE 10: PIN DEFINITION OF THE AUDIO INTERFACE.....	36
TABLE 11: MIC INPUT CHARACTERISTICS	39
TABLE 12: AUDIO OUTPUT CHARACTERISTICS	39
TABLE 13: BUZZER OUTPUT CHARACTERISTICS	40
TABLE 14: PIN DEFINITION OF THE SIM INTERFACE	41
TABLE 15: PIN DESCRIPTION (AMPHENOL SIM CARD HOLDER)	43
TABLE 16: PIN DESCRIPTION (MOLEX SIM CARD HOLDER)	44
TABLE 17: PIN DEFINITION OF THE LCD INTERFACE	45
TABLE 18: PIN DEFINITION OF THE KEYPAD INTERFACE	45
TABLE 19: ADC SPECIFICATION	46
TABLE 20: BEHAVIOURS OF THE RI.....	47
TABLE 21: WORKING STATE OF THE NETLIGHT	48
TABLE 22: PIN DEFINITION OF THE GPIO INTERFACE	49
TABLE 23: SIM900B CONDUCTED RF OUTPUT POWER.....	51
TABLE 24: SIM900B CONDUCTED RF RECEIVE SENSITIVITY	51
TABLE 25: SIM900B OPERATING FREQUENCIES.....	51
TABLE 26: ABSOLUTE MAXIMUM RATINGS.....	52
TABLE 27: SIM900B OPERATING TEMPERATURE	52
TABLE 28: SIM900B POWER SUPPLY RATINGS	52
TABLE 29: SIM900B CURRENT CONSUMPTION (VBAT=3.8V)	54
TABLE 30: THE ESD ENDURE STATUE MEASURED TABLE (TEMPERATURE: 25°C, HUMIDITY:45%)	55
TABLE 31: PIN ASSIGNMENT.....	62

Figure Index

FIGURE 1: SIM900B FUNCTIONAL DIAGRAM.....	16
FIGURE 2: TOP VIEW OF SIM900B EVB	17
FIGURE 3: REFERENCE CIRCUIT OF THE VBAT INPUT	22
FIGURE 4: REFERENCE CIRCUIT OF THE SOURCE POWER SUPPLY INPUT	23
FIGURE 5: VBAT VOLTAGE DROP DURING TRANSMIT BURST.....	23
FIGURE 6: THE MINIMAL VBAT VOLTAGE AT VBAT DROP.....	24
FIGURE 7: TURN ON SIM900B USING PWRKEY DRIVING CIRCUIT	25
FIGURE 8: TURN ON SIM900B USING PWRKEY BUTTON.....	25
FIGURE 9: TIMING OF TURN ON SIM900B USING PWRKEY	26
FIGURE 10: TIMING OF TURN OFF SIM900B USING PWRKEY.....	27
FIGURE 11: TIMING OF RESTART SIM900B.....	28
FIGURE 12: RTC SUPPLY FROM NON-CHARGEABLE BATTERY	31
FIGURE 13: RTC SUPPLY FROM RECHARGEABLE BATTERY	31
FIGURE 14: RTC SUPPLY FROM CAPACITOR	31
FIGURE 15: SEIKO XH414H-IV01E CHARGE -DISCHARGE CHARACTERISTIC.....	32
FIGURE 16: CONNECTION OF THE SERIAL INTERFACES.....	33
FIGURE 17: CONNECTION OF SOFTWARE UPGRADE AND SOFTWARE DEBUG	35
FIGURE 18: RS232 LEVEL CONVERTER CIRCUIT	35
FIGURE 19: SPEAKER INTERFACE CONFIGURATION	37
FIGURE 20: SPEAKER INTERFACE WITH AMPLIFIER CONFIGURATION	37
FIGURE 21: MICROPHONE INTERFACE CONFIGURATION.....	38
FIGURE 22: EARPHONE INTERFACE CONFIGURATION.....	38
FIGURE 23: REFERENCE CIRCUIT OF BUZZER	40
FIGURE 24: REFERENCE CIRCUIT OF THE 8 PINS SIM CARD HOLDER.....	42
FIGURE 25: REFERENCE CIRCUIT OF THE 6 PINS SIM CARD HOLDER.....	42
FIGURE 26: AMPHENOL C707 10M006 512 2 SIM CARD HOLDER.....	43
FIGURE 27: MOLEX 91228 SIM CARD HOLDER	44
FIGURE 28: REFERENCE CIRCUIT OF THE KEYPAD INTERFACE	46
FIGURE 29: RI BEHAVIOUR OF VOICE CALL AS A RECEIVER.....	47
FIGURE 30: RI BEHAVIOUR OF DATA CALL AS A RECEIVER.....	47
FIGURE 31: RI BEHAVIOUR OF URC OR RECEIVE SMS	48
FIGURE 32: RI BEHAVIOUR AS A CALLER	48
FIGURE 33: REFERENCE CIRCUIT OF NETLIGHT	49
FIGURE 34 : THE RF INTERFACE OF MODULE	50
FIGURE 35: TOP AN SIDE MECHANICAL DIMENSIONS OF MODULE (UNIT: MM)	56
FIGURE 36: MECHANICAL DIMENSIONS OF MODULE PCB DECAL (UNIT: MM)	57
FIGURE 37: TOP VIEW OF THE SIM900B.....	57
FIGURE 38: BB530-06001-20R BOARD-TO-BOARD CONNECTOR	58
FIGURE 39 :BOARD-TO-BOARD CONNECTOR PHYSICAL PHOTO	59
FIGURE 40: U.FL-R-SMT.....	60
FIGURE 41: U.FL SERIES RF ADAPTER CABLE.....	61

Version history

Date	Version	Description of change	Author
2010-04-08	1.01	Origin	Huangqiujju
2010-05-31	1.02	Modify voltage domain , current consumption and figure37	Huangqiujju
2010-06-23	1.03	§2.1, §3.3. §3.4 Modify the power supply range from 3.2V~4.8V to 3.1V~4.8V §3.7, Modify the VRTC pin connection when RTC backup is not needed.	Huangqiujju
2010-08-19	1.04	Modify the power supply range to 3.2v~4.8v. §3.3.2 Add Figure 6:The minimal VBAT voltage at VBAT drop. §3.4 Modify figure 7. §3.4 Add table 7. §3.5 Add 3.5.4 and 3.5.5 description. Delete chapter 3.6. Add figure 29,figure 30,figure 31,figure 32 Modified figure 39 and B2B connector's manufacture	Huangqiujju

1 Introduction

This document describes the hardware interface of the SIMCom SIM900B module that connects to the specific application and the air interface. As SIM900B can be integrated with a wide range of applications, all functional components of SIM900B are described in great detail.

This document can help user to quickly understand SIM900B interface specifications, electrical and mechanical details. With the help of this document and other SIM900B application notes, user guide, the user can use SIM900B module to design and set-up mobile applications quickly.

1.1 Related Documents

Table 1: Related documents

SN	Document name	Remark
[1]	SIM900_ATC	SIM900_ATC
[2]	ITU-T Draft new recommendation V.25ter:	Serial asynchronous automatic dialing and control
[3]	GSM 07.07:	Digital cellular telecommunications (Phase 2+); AT command set for GSM Mobile Equipment (ME)
[4]	GSM 07.10:	Support GSM 07.10 multiplexing protocol
[5]	GSM 07.05:	Digital cellular telecommunications (Phase 2+); Use of Data Terminal Equipment – Data Circuit terminating Equipment (DTE – DCE) interface for Short Message Service (SMS) and Cell Broadcast Service (CBS)
[6]	GSM 11.14:	Digital cellular telecommunications system (Phase 2+); Specification of the SIM Application Toolkit for the Subscriber Identity Module – Mobile Equipment (SIM – ME) interface
[7]	GSM 11.11:	Digital cellular telecommunications system (Phase 2+); Specification of the Subscriber Identity Module – Mobile Equipment (SIM – ME) interface
[8]	GSM 03.38:	Digital cellular telecommunications system (Phase 2+); Alphabets and language-specific information
[9]	GSM 11.10	Digital cellular telecommunications system (Phase 2); Mobile Station (MS) conformance specification; Part 1: Conformance specification
[10]	AN_Serial Port	AN_Serial Port

1.2 Terms and Abbreviations

Table 2: Terms and Abbreviations

Abbreviation	Description
ADC	Analog-to-Digital Converter
AMR	Adaptive Multi-Rate
ARP	Antenna Reference Point
ASIC	Application Specific Integrated Circuit
BER	Bit Error Rate
BTS	Base Transceiver Station
CHAP	Challenge Handshake Authentication Protocol
CS	Coding Scheme
CSD	Circuit Switched Data
CTS	Clear to Send
DAC	Digital-to-Analog Converter
DRX	Discontinuous Reception
DSP	Digital Signal Processor
DTE	Data Terminal Equipment (typically computer, terminal, printer)
DTR	Data Terminal Ready
DTX	Discontinuous Transmission
EFR	Enhanced Full Rate
EGSM	Enhanced GSM
EMC	Electromagnetic Compatibility
ESD	Electrostatic Discharge
ETS	European Telecommunication Standard
FCC	Federal Communications Commission (U.S.)
FDMA	Frequency Division Multiple Access
FR	Full Rate
GMSK	Gaussian Minimum Shift Keying
GPRS	General Packet Radio Service
GSM	Global Standard for Mobile Communications
HR	Half Rate
I/O	Input/Output
IC	Integrated Circuit
IMEI	International Mobile Equipment Identity
kbps	Kilo bits per second
LED	Light Emitting Diode
Li-Ion	Lithium-Ion
MO	Mobile Originated

SIM900B Hardware Design

MS	Mobile Station (GSM engine), also referred to as TE
MT	Mobile Terminated
Abbreviation	Description
PAP	Password Authentication Protocol
PBCCH	Packet Switched Broadcast Control Channel
PCB	Printed Circuit Board
PCS	Personal Communication System, also referred to as GSM 1900
PDU	Protocol Data Unit
PPP	Point-to-point protocol
RF	Radio Frequency
RMS	Root Mean Square (value)
RTC	Real Time Clock
RX	Receive Direction
SIM	Subscriber Identification Module
SMS	Short Message Service
TDMA	Time Division Multiple Access
TE	Terminal Equipment, also referred to as DTE
TX	Transmit Direction
UART	Universal Asynchronous Receiver & Transmitter
URC	Unsolicited Result Code
USSD	Unstructured Supplementary Service Data
VSWR	Voltage Standing Wave Ratio
Vmax	Maximum Voltage Value
Vnorm	Normal Voltage Value
Vmin	Minimum Voltage Value
VIHmax	Maximum Input High Level Voltage Value
VIHmin	Minimum Input High Level Voltage Value
VILmax	Maximum Input Low Level Voltage Value
VILmin	Minimum Input Low Level Voltage Value
VImax	Absolute Maximum Input Voltage Value
VImin	Absolute Minimum Input Voltage Value
VOHmax	Maximum Output High Level Voltage Value
VOHmin	Minimum Output High Level Voltage Value
VOLmax	Maximum Output Low Level Voltage Value
VOLmin	Minimum Output Low Level Voltage Value

SIM900B Hardware Design

Inorm	Normal Current
Imax	Maximum Load Current
<i>Phonebook abbreviations</i>	
Abbreviation	Description
FD	SIM fix dialing phonebook
LD	SIM last dialing phonebook (list of numbers most recently dialed)
MC	Mobile Equipment list of unanswered MT calls (missed calls)
ON	SIM (or ME) own numbers (MSISDNs) list
RC	Mobile Equipment list of received calls
SM	SIM phonebook
NC	Not connect

1.3 Safety Caution

The following safety precautions must be observed during all phases of the operation. Usage, service or repair of any cellular terminal or mobile incorporating SIM900B module. Manufactures of the cellular terminal should send words the following safety information to users and operating personnel and to incorporate these guidelines into all manuals supplied with the product. If not so, SIMCom does not take on any liability for customer failure to comply with these precautions.



When in a hospital or other health care facility, observe the restrictions about the use of mobiles. Switch the cellular terminal or mobile off, medical equipment may be sensitive to not operate normally for RF energy interference.



Switch off the cellular terminal or mobile before boarding an aircraft. Make sure it be switched off. The operation of wireless appliances in an aircraft is forbidden to prevent interference with communication systems. Forget to think much of these instructions may lead to the flight safety or offend against local legal action, or both.



Do not operate the cellular terminal or mobile in the presence of flammable gases or fumes. Switch off the cellular terminal when you are near petrol stations, fuel depots, chemical plants or where blasting operations are in progress. Operation of any electrical equipment in potentially explosive atmospheres can constitute a safety hazard.



Your cellular terminal or mobile receives and transmits radio frequency energy while switched on. RF interference can occur if it is used close to TV sets, radios, computers or other electric equipment.



Road safety comes first! Do not use a hand-held cellular terminal or mobile when driving a vehicle, unless it is securely mounted in a holder for hands free operation. Before making a call with a hand-held terminal or mobile, park the vehicle.



GSM cellular terminals or mobiles operate over radio frequency signals and cellular networks and cannot be guaranteed to connect in all conditions, for example no mobile fee or a invalid SIM card. While you are in this condition and need emergent help, Please Remember using emergency calls. In order to make or receive calls, the cellular terminal or mobile must be switched on and in a service area with adequate cellular signal strength.

Some networks do not allow for emergency call if certain network services or phone features are in use (e.g. lock functions, fixed dialing etc.). You may have to deactivate those features before you can make an emergency call.

Also, some networks require that a valid SIM card be properly inserted in the cellular terminal or mobile.

2 SIM900B Overview

Designed for global market, SIM900B is a quad-band GSM/GPRS engine that works on frequencies GSM 850MHz, EGSM 900MHz, DCS 1800MHz and PCS 1900MHz. SIM900B features GPRS multi-slot class 10/class 8 (optional) and supports the GPRS coding schemes CS-1, CS-2, CS-3 and CS-4.

With a tiny configuration of 40mm x 33mm x 3mm, SIM900B can meet almost all the space requirements in the applications, such as M2M, smart phone, PDA and other mobile devices.

The physical interface to the mobile application is a 60-pin board-to-board connector, which provides all hardware interfaces between the module and customers' boards except the RF antenna interface.

- The keypad and SPI display interface will give user the flexibility to develop customized applications.
- Serial port and Debug port can help user easily develop the applications.
- Two audio channels include a microphone input and a speaker output.
- Programmable general purpose input & output.

The SIM900B is designed with power saving technique so that the current consumption is as low as 1.2mA in SLEEP mode.

The SIM900B is integrated with the TCP/IP protocol; extended TCP/IP AT commands are developed for customers to use the TCP/IP protocol easily, which is very useful for those data transfer applications.

2.1 SIM900B Key Features

Table 3: SIM900B key features

Feature	Implementation
Power supply	Single supply voltage :3.2V – 4.8V
Power saving	Typical power consumption in SLEEP mode is 1.0mA (BS-PA-MFRMS=9)
Frequency Bands	<ul style="list-style-type: none"> ● Quad-band: GSM 850, EGSM 900, DCS 1800, PCS 1900. The SIM900B can search the 4 frequency bands automatically. The frequency bands also can be set by AT command. ● Compliant to GSM Phase 2/2+
GSM class	Small MS
Transmitting power	<ul style="list-style-type: none"> ● Class 4 (2W) at GSM 850 and EGSM 900 ● Class 1 (1W) at DCS 1800 and PCS 1900
GPRS connectivity	<ul style="list-style-type: none"> ● GPRS multi-slot class 10 (default) ● GPRS multi-slot class 8 (option) ● GPRS mobile station class B

SIM900B Hardware Design

Temperature range	<ul style="list-style-type: none"> ● Normal operation: -30°C to +80°C ● Restricted operation: -40°C to -30°C and +80 °C to +85°C⁽¹⁾ ● Storage temperature -45°C to +90°C
DATA GPRS: CSD:	<ul style="list-style-type: none"> ● GPRS data downlink transfer: max. 85.6 kbps ● GPRS data uplink transfer: max. 42.8 kbps ● Coding scheme: CS-1, CS-2, CS-3 and CS-4 ● Supports the protocols PAP (Password Authentication Protocol) usually used for PPP connections. ● Integrates the TCP/IP protocol. ● Support Packet Switched Broadcast Control Channel (PBCCH) ● CSD transmission rates: 2.4, 4.8, 9.6, 14.4 kbps, non-transparent ● Unstructured Supplementary Services Data (USSD) support
SMS	<ul style="list-style-type: none"> ● MT, MO, CB, Text and PDU mode ● SMS storage: SIM card
FAX	Group 3 Class 1
SIM interface	Support SIM card: 1.8V, 3V
External antenna	Connected via 50 Ohm antenna connector or antenna pad
Audio features	<p>Speech codec modes:</p> <ul style="list-style-type: none"> ● Half Rate (ETS 06.20) ● Full Rate (ETS 06.10) ● Enhanced Full Rate (ETS 06.50 / 06.60 / 06.80) ● Adaptive multi rate (AMR) ● Echo Cancellation ● Noise Suppression
Serial port and Debug port	<p>Serial Port:</p> <ul style="list-style-type: none"> ● 7-wire modem interface with status and control lines, unbalanced, asynchronous. ● 1200bps to 115200bps. ● Serial Port can be used for AT commands or data stream. ● Supports RTS/CTS hardware handshake and software ON/OFF flow control. ● Multiplex ability according to GSM 07.10 Multiplexer Protocol. ● Autobauding supports baud rate from 1200 bps to 57600bps. <p>Debug port:</p> <ul style="list-style-type: none"> ● 2-wire interface DBG_TXD and DBG_RXD. ● Can be used for debugging and firmware upgrade.
Phonebook management	Support phonebook types: SM, FD, LD, RC, ON, MC.
SIM Application Toolkit	Support SAT class 3, GSM 11.14 Release 99
Real time clock	Implemented
Timer function	Programmable via AT command
Physical characteristics	<p>Size: 40mm x 33mm x 3.0mm</p> <p>Weight: 7g</p>
Firmware upgrade	Firmware upgrade over debug port.

(1) The SIM900B does work, but deviations from the GSM specification may occur.

Table 4: Coding schemes and maximum data rates over air interface

Coding scheme	1 Timeslot	2 Timeslot	4 Timeslot
CS-1:	9.05kbps	18.1kbps	36.2kbps
CS-2:	13.4kbps	26.8kbps	53.6kbps
CS-3:	15.6kbps	31.2kbps	62.4kbps
CS-4:	21.4kbps	42.8kbps	85.6kbps

2.2 SIM900B Functional Diagram

The following figure shows a functional diagram of the SIM900B and illustrates the mainly functional part:

- The GSM baseband engine
- Flash and SRAM
- The GSM radio frequency part
- The antenna interface
- The board-to-board interface
- The Other interfaces

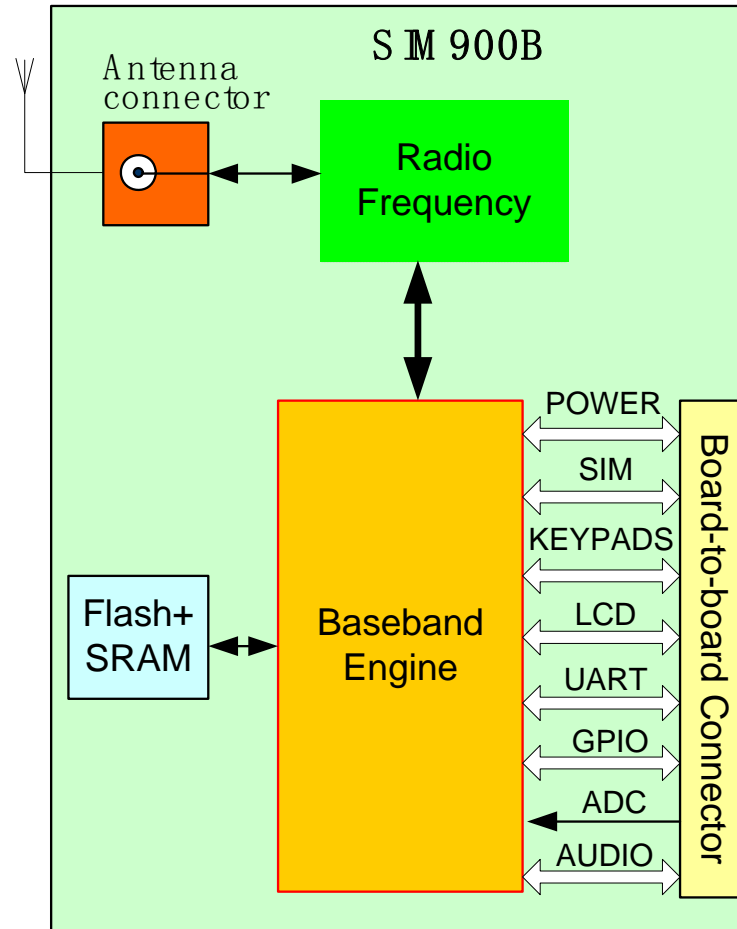

Figure 1: SIM900B functional diagram

2.3 SIM900B Evaluation Board

In order to help user on the application of SIM900B, SIMCom can supply an Evaluation Board (EVB) that interfaces the SIM900B directly with appropriate power supply, SIM card holder, RS232 serial port, handset port, earphone port, antenna and all GPIO of the SIM900B.



Figure 2: Top view of SIM900B EVB

For details please refer to the *SIM900B-EVB_UGD* document.

3 Application Interface

SIM900B is equipped with a 60-pin 0.5mm pitch board-to-board connector that connects to the cellular application platform. Sub-interfaces included in this board-to-board connector are described in detail in following chapters:

- Power supply (*please refer to Chapter 3.3*)
- Serial interfaces (*please refer to Chapter 3.8*)
- Analog audio interfaces (*please refer to Chapter 3.9*)
- SIM interface (*please refer to Chapter 3.11*)

Electrical and mechanical characteristics of the board-to-board connector are specified in *Chapter 6*. There also include order information for mating connectors.

3.1 SIM900B Pin Description

Table 5: Pin description

Power Supply				
PIN NAME	I/O	DESCRIPTION	DC CHARACTERISTICS	COMMENT
VBAT	I	8 VBAT pins are dedicated to connect the supply voltage. The power supply of SIM900B has to be a single voltage source of VBAT= 3.2V..4.8V. It must be able to provide sufficient current in a transmit burst which typically rises to 2A	Vmax= 4.8V Vmin=3.2V Vnorm=4.0V	
VRTC	I/O	Current input for RTC when the battery is not supplied for the system. Current output for backup battery when the main battery is present and the backup battery is in low voltage state.	Vmax=3.15V Vmin=2.0V Vnorm=3.0V Iout(max)= 200uA Iin=3 uA	If the RTC function is enabled, a backup battery or capacitor should be connected to the VRTC pin. Otherwise connect a 4.7uF capacitor to the VRTC pin.
VDD_EXT	O	2.8V output power supply	Vmax=2.95V Vmin=2.70V Vnorm=2.80V Iout(max)= 10mA	If unused, keep open.

SIM900B Hardware Design

GND		Ground		
Power on or power off				
PIN NAME	I/O	DESCRIPTION	DC CHARACTERISTICS	
PWRKEY	I	Power on/off detect, active low.	VILmax=0.9V VIHmin=2.6V VImax=3.3V VILmin= 0V	It is already pulled up internally (3V).
Audio interfaces				
PIN NAME	I/O	DESCRIPTION	DC CHARACTERISTICS	COMMENT
MIC1P MIC1N	I	Positive and negative voice-band input	Audio DC Characteristics refer to chapter 3.9.4	If unused keep open
MIC2P MIC2N	I	Auxiliary positive and negative voice-band input		
SPK1P SPK1N	O	Positive and negative voice-band output		If unused keep open
SPK2P SPK2N	O	Auxiliary positive and negative voice-band output		
AGND		Analog ground		Separate ground connection for external audio circuits. If unused keep open.
Display interface				
PIN NAME	I/O	DESCRIPTION	DC CHARACTERISTICS	COMMENT
DISP_RST	O	Display interface	VILmax=0.15 *VDD_EXT VIHmin=0.85*VDD_EXT VILmin= 0V VIHmax= VDD_EXT VOHmin= VDD_EXT-0.1V VOLmax=0.1V VOHmax= VDD_EXT VOLmin= 0V	If unused keep open
DISP_DATA	I/O			
DISP_CLK	O			
DISP_CS	O			
DISP_D/C	O			
General purpose input/output				
GPIO1/ KBC4	I/O	Default as GPIO,can be multiplexed as keypad	VILmax=0.15 *VDD_EXT VIHmin=0.85*VDD_EXT VILmin= 0V VIHmax= VDD_EXT	If unused keep open
GPIO2/ KBC3	I/O			
GPIO3/ KBC2	I/O			
GPIO4/ KBC1	I/O			

SIM900B Hardware Design

GPIO6/ KBR3	I/O		VOHmin= VDD_EXT-0.1V VOLmax=0.1V VOHmax= VDD_EXT VOLmin= 0V	Just can be used as GPIO,if unused keep open
GPIO7/ KBR4	I/O			
GPIO8/ KBR2	I/O			
GPIO9/ KBR1	I/O			
GPIO5/KBC0	I/O			
GPIO10/KBR0	I/O			

Serial port

PIN NAME	I/O	DESCRIPTION	DC CHARACTERISTICS	COMMENT
RXD	I	Receive data	VILmax=0.15 *VDD_EXT	If RXD pin not used, it should be pulled up to VDD_EXT. DTR Pin has been pulled up to VDD_EXT internally. Other unused pins can keep open
TXD	O	Transmit data	VIHmin=0.85*VDD_EXT	
RTS	I	Request to send	VILmin= 0V	
CTS	O	Clear to send	VIHmax= VDD_EXT	
RI	O	Ring indicator	VOHmin= VDD_EXT-0.1V	
DCD	O	Data carry detect	VOLmax=0.1V	
DTR	I	Data terminal Ready	VOHmax= VDD_EXT	
			VOLmin= 0V	

Debug interface

PIN NAME	I/O	DESCRIPTION	DC CHARACTERISTICS	COMMENT
DBG_TXD	O	Serial interface for debugging and firmware upgrade	VILmax=0.15 *VDD_EXT	If unused keep open
DBG_RXD	I		VIHmin=0.85*VDD_EXT VILmin= 0V VIHmax= VDD_EXT VOHmin= VDD_EXT-0.1V VOLmax=0.1V VOHmax= VDD_EXT VOLmin= 0V	

SIM interface

PIN NAME	I/O	DESCRIPTION	DC CHARACTERISTICS	COMMENT
SIM_VDD	O	Voltage supply for SIM card	The voltage can be select by software automatically either 1.8V or 3V	If unused keep open
SIM_DATA	I/O	SIM data output	VILmax=0.15 *SIM_VDD	
SIM_CLK	O	SIM clock	VIHmin=0.85*SIM_VDD	

SIM900B Hardware Design

SIM_RST	O	SIM reset	$V_{ILmin} = 0V$ $V_{IHmax} = SIM_VDD$ $V_{OHmin} = SIM_VDD - 0.1V$ $V_{OLmax} = 0.1V$ $V_{OHmax} = SIM_VDD$ $V_{OLmin} = 0V$	
SIM_PRESENCE	I	SIM detect	$V_{ILmax} = 0.15 * VDD_EXT$ $V_{IHmin} = 0.85 * VDD_EXT$ $V_{ILmin} = 0V$ $V_{IHmax} = VDD_EXT$	

ADC

PIN NAME	I/O	DESCRIPTION	DC CHARACTERISTICS	COMMENT
ADC0	I	General purpose analog to digital converter.	Input voltage range: 0V ~ 2.8V	If unused keep open

Pulse Width Modulation

PIN NAME	I/O	DESCRIPTION	DC CHARACTERISTICS	COMMENT
BUZZER	O	PWM Output	$V_{OHmin} = VDD_EXT - 0.1V$ $V_{OLmax} = 0.1V$ $V_{OHmax} = VDD_EXT$ $V_{OLmin} = 0$	If unused keep open

3.2 Operating Modes

The table below briefly summarizes the various operating modes referred to in the following chapters.

Table 6: Overview of operating modes

Mode	Function	
Normal operation	GSM/GPRS	Module will automatically go into SLEEP mode if DTR is set to high level and there is no on air and no hardware interrupt (such as GPIO interrupt or data on serial port). In this case, the current consumption of module will reduce to the minimal level. In SLEEP mode, the module can still receive paging message and SMS from the BTS normally.
	SLEEP	
	GSM IDLE	Software is active. Module has registered to the GSM network, and the module is ready to send and receive.

SIM900B Hardware Design

	GSM TALK	Connection between two subscribers is in progress. In this case, the power consumption depends on network settings such as DTX off/on, FR/EFR/HR, hopping sequences, antenna.
	GPRS STANDBY	Module is ready for GPRS data transfer, but no data is currently sent or received. In this case, power consumption depends on network settings and GPRS configuration.
	GPRS DATA	There is GPRS data transfer (PPP or TCP or UDP) in progress. In this case, power consumption is related with network settings (e.g. power control level), uplink / downlink data rates and GPRS configuration (e.g. used multi-slot settings).
Power down		Normal shutdown by sending the “AT+CPOWD=1” command or using the PWRKEY. The power management ASIC disconnects the power supply from the baseband part of the module, and only the power supply for the RTC is remained. Software is not active. The serial port is not accessible. Operating voltage (connected to VBAT) remains applied.
Minimum functionality mode (without remove power supply)		Use the “AT+CFUN” command can set the module to a minimum functionality mode without remove the power supply. In this case, the RF part of the module will not work or the SIM card will not be accessible, or both RF part and SIM card will be closed, and the serial port is still accessible. The power consumption in this case is very low.

3.3 Power Supply

The power supply of SIM900B is from a single voltage source of VBAT= 3.2V...4.8V. In some case, the ripple in a transmitting burst may cause voltage drops when current consumption rises to typical peaks of 2A. So the power supply must be able to provide sufficient current up to 2A.

For the VBAT input, a local bypass capacitor is recommended. A capacitor (about 100 μ F, low ESR) is recommended. Multi-layer ceramic chip (MLCC) capacitors can provide the best combination of low ESR and small size but may not be cost effective. A lower cost choice may be a 100 μ F tantalum capacitor (low ESR) with a small (0.1 μ F to 1 μ F) ceramic in parallel, which is illustrated as following figure. The capacitors should be placed as close as possible to the SIM900B VBAT pins. The following figure is the recommended circuit.

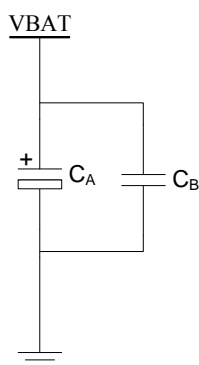

Figure 3: Reference circuit of the VBAT input

The circuit design of the power supply depends strongly upon the power source where this power is drained. The following figure is the reference design of +5V input source power supply. The designed output for the power supply is 4.1V, thus a linear regulator can be used. If there's a big difference between the input source and the desired output (VBAT), a switching converter power supply will be preferable because of its better efficiency especially with the 2A peak current in burst mode of the module.

A single 3.6V Li-Ion cell battery type can be connected to the power supply of the SIM900B VBAT directly. But the Ni_Cd or Ni_MH battery types must be used carefully, since their maximum voltage can rise over the absolute maximum voltage of the module and damage it.

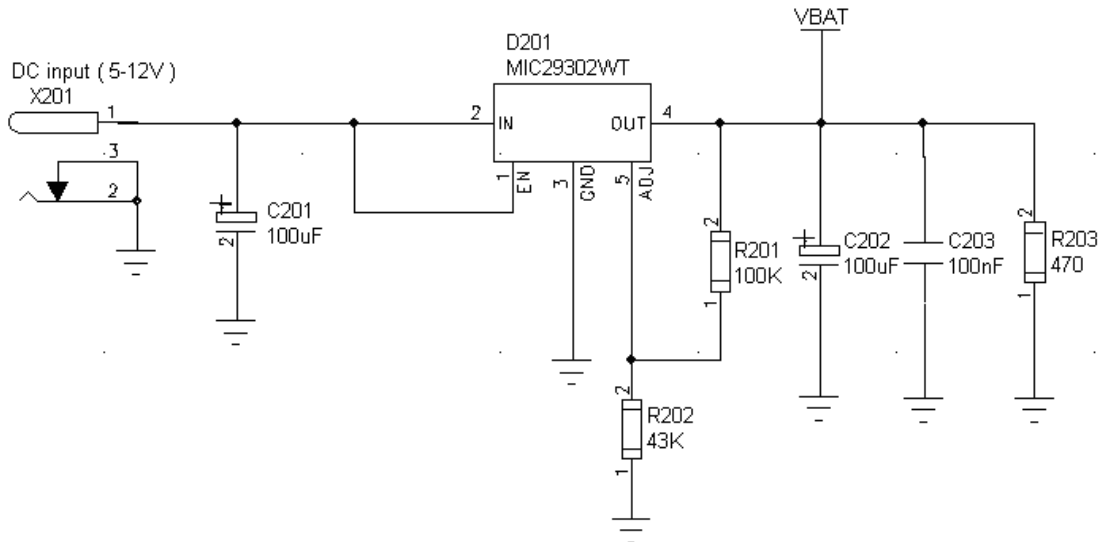

Figure 4: Reference circuit of the source power supply input

The following figure is the VBAT voltage ripple wave at the maximum power transmit phase, the test condition is VBAT=4.0V, VBAT maximum output current =2A, $C_A=100\mu\text{F}$ tantalum capacitor (ESR=0.7 Ω) and $C_B=1\mu\text{F}$.

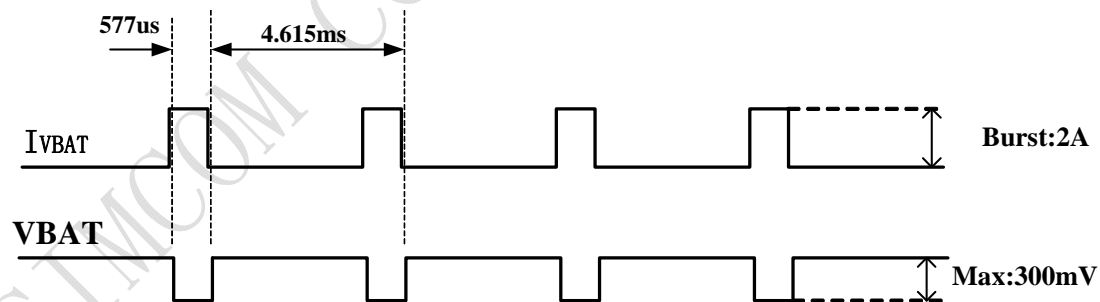

Figure 5: VBAT voltage drop during transmit burst

3.3.1 Power Supply Pins

Eight VBAT pins of the board-to-board connector are dedicated to connect the supply voltage; six GND pins are recommended for grounding. VRTC pin can be used to back up the RTC.

3.3.2 Minimizing Power Losses

When designing the power supply for user's application please pay specific attention to power losses. Ensure that the input voltage VBAT never drops below 3.1V even in a transmit burst where current consumption can rise to typical peaks of 2A. If the power voltage drops below 3.1V, the module may be shut down automatically. The PCB traces from the VBAT pins to the power source must be wide enough to decrease voltage drops in the transmitting burst mode.

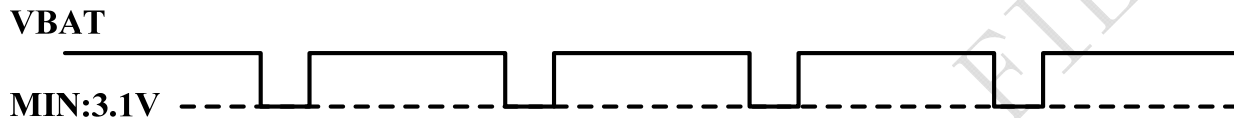

Figure 6: The minimal VBAT voltage at VBAT drop

3.3.3 Monitoring Power Supply

To monitor the supply voltage, user can use the “AT+CBC” command which includes a parameter: voltage value (in mV).

The voltage is continuously measured at intervals depending on the operating mode. The displayed voltage (in mV) is averaged over the last measuring period before the AT command “AT+CBC” is executed.

For details information about “AT+CBC” please refer to *document [1]*

3.4 Power Up and Power Down Scenarios

In general, be sure not to turn on SIM900B while it is beyond the safety limits of voltage and temperature stated in Chapter 3.4.2. SIM900 would immediately power down after the module having started and detected these inappropriate conditions. In extreme cases this can cause permanent damage to the module.

3.4.1 Turn On SIM900B

SIM900B can be turned on by the following way, which is described in following chapters:

- Via PWRKEY pin: starts normal operating mode (*please refer to chapter 3.4.1.1*);

Note: The AT command must be set after the SIM900B is powered on and Unsolicited Result Code “RDY” is received from the serial port. However if the SIM900B is set to autobauding, the serial port will receive nothing. The AT commands can be set after the SIM900B is powered on. User can use AT+IPR=x to set a fixed baud rate and save the configuration to non-volatile flash memory. After the configuration is saved as fixed baud rate, the Code “RDY” should be received from the serial port all the time that the SIM900B is

powered on. Please refer to the chapter “AT+IPR” in document [1].

3.4.1.1 Turn On SIM900B Using the PWRKEY Pin (Power On)

User can turn on the SIM900B by driving the PWRKEY to a low level voltage for a short time and then release. This pin has pulled up to 3V in the module. The simple circuit illustrates as the following figures.

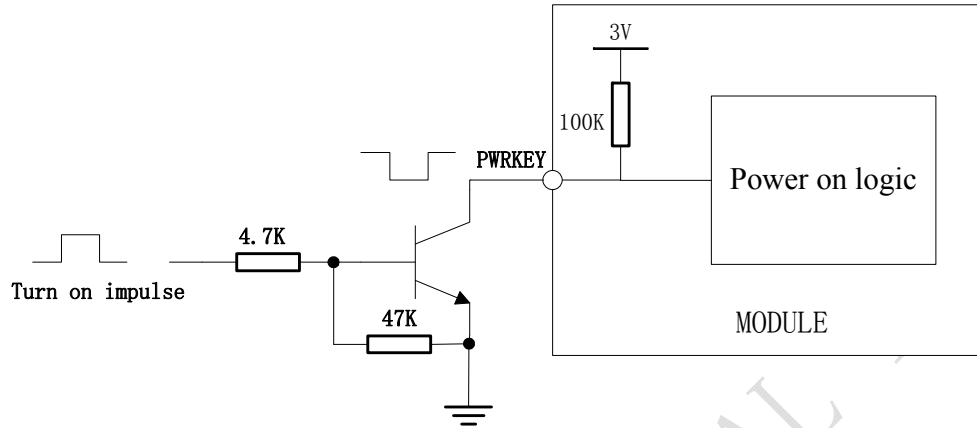

Figure 7: Turn on SIM900B using PWRKEY driving circuit

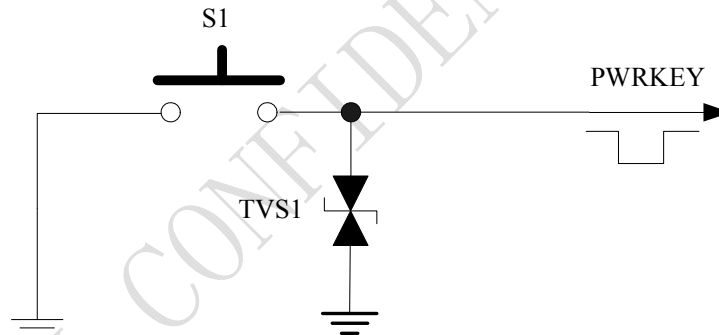

Figure 8: Turn on SIM900B using PWRKEY button

The power on scenarios illustrates as following figure.

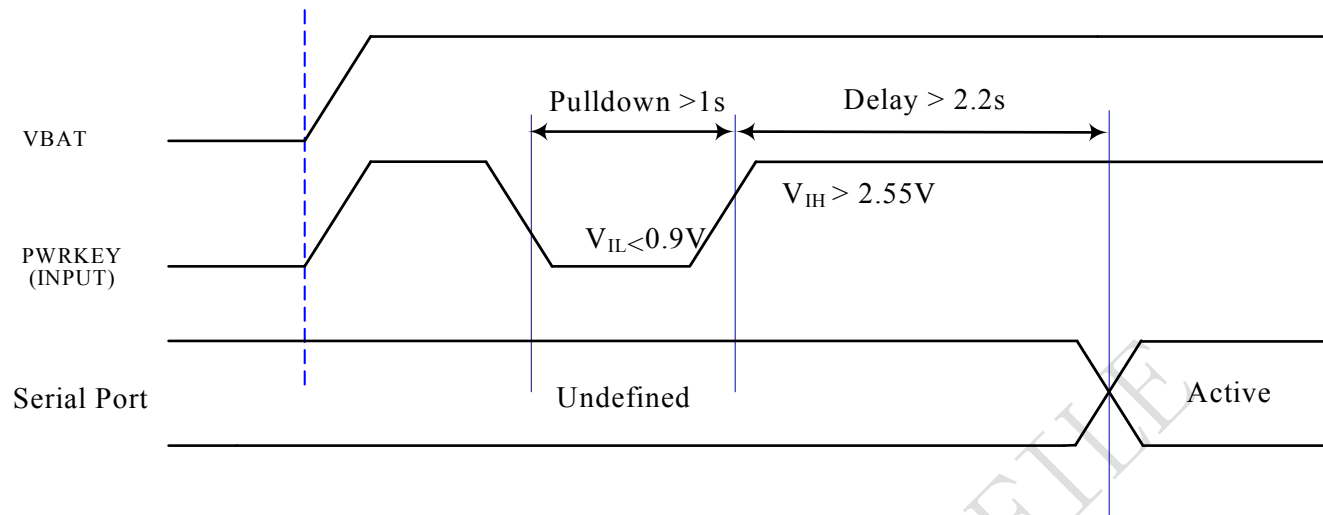

Figure 9: Timing of turn on SIM900B using PWRKEY

When power on procedure completes, the SIM900B will send out following result code to indicate the module is ready to operate when set as fixed baud rate.

RDY

This result code does not appear when autobauding is active.

3.4.2 Turn Off SIM900B

Following ways can be used to turn off the SIM900B:

- Normal power down procedure: Turn off SIM900B using the PWRKEY pin
- Normal power down procedure: Turn off SIM900B using AT command
- Over-voltage or under-voltage automatic shutdown: Take effect if over-voltage or under-voltage is detected
- Over-temperature or under-temperature automatic power down: Take effect if over-temperature or under-temperature is detected

3.4.2.1 Turn Off SIM900B Using the PWRKEY Pin (Power Down)

The SIM900B can be turned off by driving the PWRKEY to a low level voltage for a short time and then release. Please refer to the turn on circuit. The power down scenario illustrates as following figure.

This procedure lets the module log off from the network and allows the software to enter into a secure state and save data before completely disconnecting the power supply.

Before the completion of the power down procedure the module will send out result code:

NORMAL POWER DOWN

After this moment, the AT commands can't be executed. The module enters the POWER DOWN mode, only the RTC is still active. POWER DOWN can also be indicated by VDD_EXT pin, which is a low level voltage in this

mode.

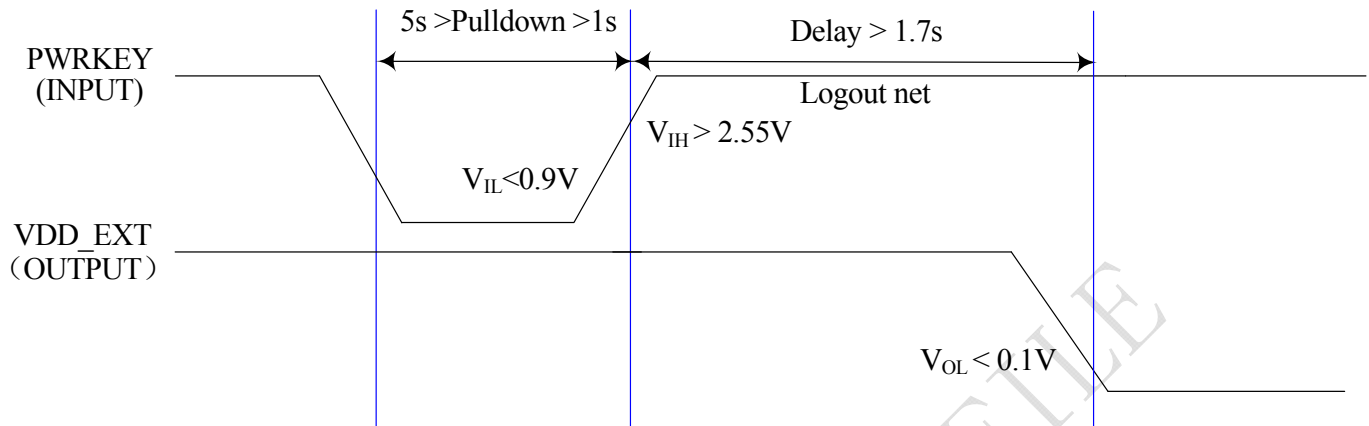

Figure 10: Timing of turn off SIM900B using PWRKEY

3.4.2.2 Turn Off SIM900B Using AT Command

AT command “AT+CPOWD=1” can be used to turn off the module. This command lets the module log off from the network and allows the module to enter into a secure state and save data before completely disconnecting the power supply.

Before the completion of the power down procedure the module will send out result code:

NORMAL POWER DOWN

After this moment, the AT commands can not be executed. The module enters the POWER DOWN mode, only the RTC is still active. POWER DOWN can also be indicated by VDD_EXT pin, which is a low level voltage in this mode.

Please refer to *document [1]* for detail about the AT command of “AT+CPOWD”.

3.4.2.3 Over-voltage or Under-voltage Automatic Power Down

The module will constantly monitor the voltage applied on the VBAT. If the voltage $\leq 3.3V$, the following URC will be presented:

UNDER-VOLTAGE WARNING

If the voltage $\geq 4.7V$, the following URC will be presented:

OVER-VOLTAGE WARNING

The uncritical voltage range is 3.2V to 4.8V. If the voltage $> 4.8V$ or $< 3.2V$, the module will be automatic power down soon.

If the voltage $< 3.2V$, the following URC will be presented:

UNDER-VOLTAGE POWER DOWN

If the voltage $> 4.8V$, the following URC will be presented:

OVER-VOLTAGE POWER DOWN

After this moment, no further more AT commands can be executed. The module logs off from network and enters

POWER DOWN mode, and only the RTC is still active. POWER DOWN can also be indicated by VDD_EXT pin, which is a low level voltage in this mode.

3.4.2.4 Over-temperature or Under-temperature Automatic Power Down

The module will constantly monitor the temperature of the module, if the temperature $> +80^{\circ}\text{C}$, the following URC will be presented:

+CMTE:1

If the temperature $< -30^{\circ}\text{C}$, the following URC will be presented:

+CMTE:-1

The uncritical temperature range is -40°C to $+85^{\circ}\text{C}$. If the temperature $> +85^{\circ}\text{C}$ or $< -40^{\circ}\text{C}$, the module will be automatic power down soon.

If the temperature $> +85^{\circ}\text{C}$, the following URC will be presented:

+CMTE:2

If the temperature $< -40^{\circ}\text{C}$, the following URC will be presented:

+CMTE:-2

After this moment, the AT commands can not be executed. The module logs off from network and enters POWER DOWN mode, and only the RTC is still active. POWER DOWN can also be indicated by VDD_EXT pin, which is a low level voltage in this mode.

To monitor the temperature, the “AT+CMTE” command can be used to read the temperature when the module is power on.

For details please refer to *document [1]*

3.4.3 Restart SIM900B Using the PWRKEY Pin

By driving the PWRKEY to a low level voltage for a short time and then release, SIM900B can be restarted, the timing is the same as turning on SIM900B using the PWRKEY pin. Before restarting the SIM900B, there need delay at least 500ms from detecting the VDD_EXT low level on. The restarting scenario illustrates as the following figure.

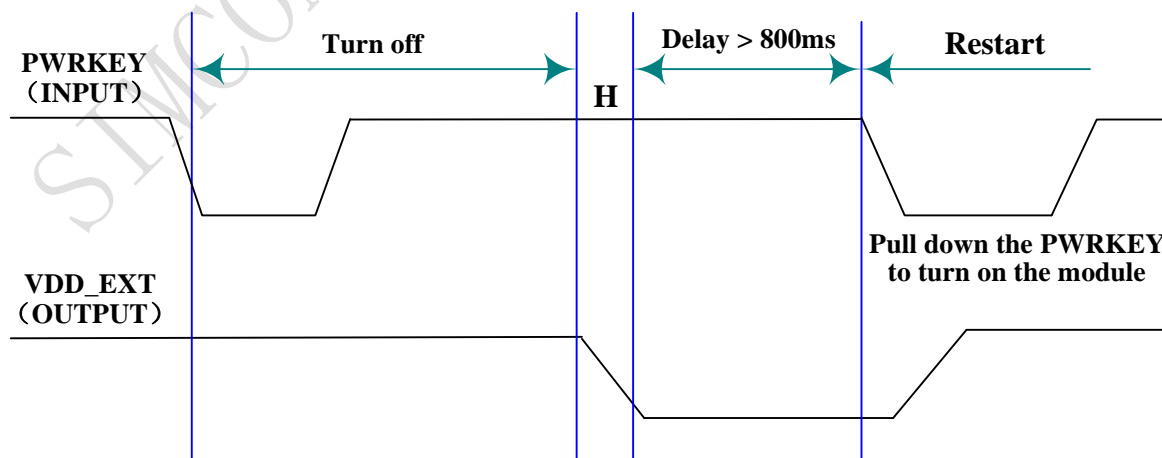

Figure 11: Timing of restart SIM900B

3.5 Power Saving

There are two methods for the module to enter into low current consumption status. “AT+CFUN” is used to set module into minimum functionality mode and DTR signal can be used to control system enter or exit SLEEP mode (or slow clocking mode).

3.5.1 Minimum Functionality Mode

Minimum functionality mode reduces the functionality of the module to a minimum and, thus, minimizes the current consumption to the lowest level. This mode is set with the “AT+CFUN” command which provides the choice of the functionality levels <fun>=0, 1, 4

- 0: minimum functionality;
- 1: full functionality (default);
- 4: disable phone both transmit and receive RF circuits;

Table 7: The Current consumption of different configuration of AT+CFUN

MODE	SLEEP		
	1	4	0
AT+CFUN	1	4	0
Current Consumption(uA)	960	715	651

If SIM900B has been set to minimum functionality by “AT+CFUN=0”, the RF function and SIM card function will be closed. In this case, the serial port is still accessible, but all AT commands correlative with RF function or SIM card function will not be accessible.

If SIM900B has been set by “AT+CFUN=4”, the RF function will be closed, the serial port is still active. In this case all AT commands correlative with RF function will not be accessible.

After SIM900B has been set by “AT+CFUN=0” or “AT+CFUN=4”, it can return to full functionality by “AT+CFUN=1”.

For detailed information about “AT+CFUN”, please refer to *document [1]*.

3.5.2 Sleep Mode (CSCLK=1) (Slow Clock Mode)

User can control SIM900 module to enter or exit the SLEEP mode(CSCLK=1) in customer applications through DTR signal.

When DTR is in high level and there is no on air and hardware interrupt (such as GPIO interrupt or data in serial port), SIM900B will enter SLEEP mode automatically. In this mode, SIM900B can still receive paging or SMS from network but the serial port is not accessible.

Note: For SIM900B, it requests to set AT command “AT+CSCLK=1” to enable the SLEEP mode; the default value is 0, that can not make the module enter SLEEP mode. For more details please refer to *document [1]*.

3.5.3 Wake Up SIM900B from SLEEP Mode(CSCLK=1)

When SIM900B is in SLEEP mode(CSCLK=1), the following methods can wake up the module.

- Enable DTR pin to wake up SIM900B.
If DTR pin is pulled down to a low level, this signal will wake up SIM900B from SLEEP mode. The serial port will be active after DTR changed to low level for about 50ms.
- Receiving a voice or data call from network to wake up SIM900B.
- Receiving a SMS from network to wake up SIM900B.

3.5.4 Sleep Mode(CSCLK=2) (Slow Clock Mode)

In this mode, the SIM900B will continuously monitor the main serial port data signal. When there has no data transferred exceed 5 seconds on the RXD signal and there is no on air and hardware interrupt (such as GPIO interrupt or data in serial port), SIM900B will enter SLEEP mode automatically. In this mode, SIM900B can still receive paging or SMS from network but the serial port is not accessible.

Note: For SIM900B, it requests to set AT command “AT+CSCLK=2” to enable the SLEEP mode; the default value is 0, that can not make the module enter SLEEP mode. For more details please refer to document [1].

3.5.5 Wake Up SIM900B from SLEEP Mode(CSCLK=2)

When SIM900B is in SLEEP mode(CSCLK=2), the following methods can wake up the module.

- User can send data to SIM900B using main serial port, when SIM900B detect the change on the RXD. The first byte data of user will not be send via module.
- Receiving a voice or data call from network to wake up SIM900B.
- Receiving a SMS from network to wake up SIM900B.

3.6 RTC Backup

The RTC power supply of module can be provided by an external capacitor or a battery (rechargeable or non-chargeable) through the VRTC.

Note: The VRTC could not be designed to a NC pin in user’s circuit. User should connect the VRTC pin to a battery or a capacitor.

The following figures show various sample circuits for RTC backup.

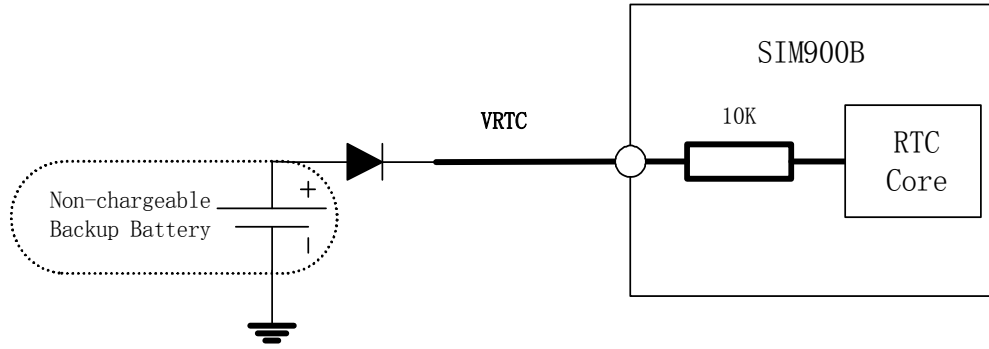

Figure 12: RTC supply from non-chargeable battery

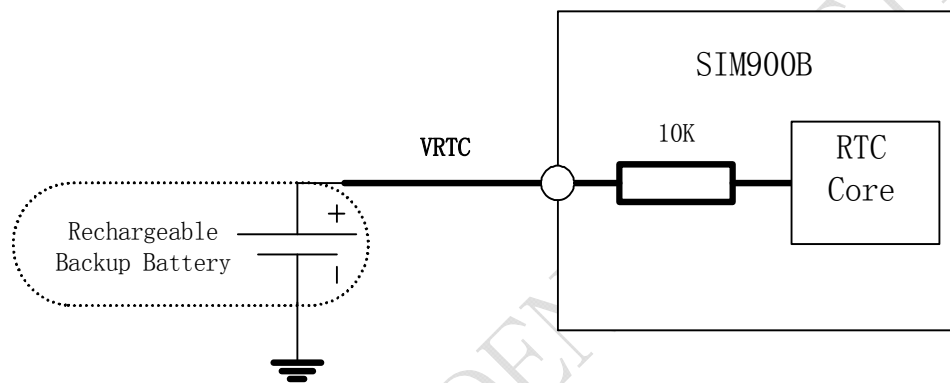

Figure 13: RTC supply from rechargeable battery

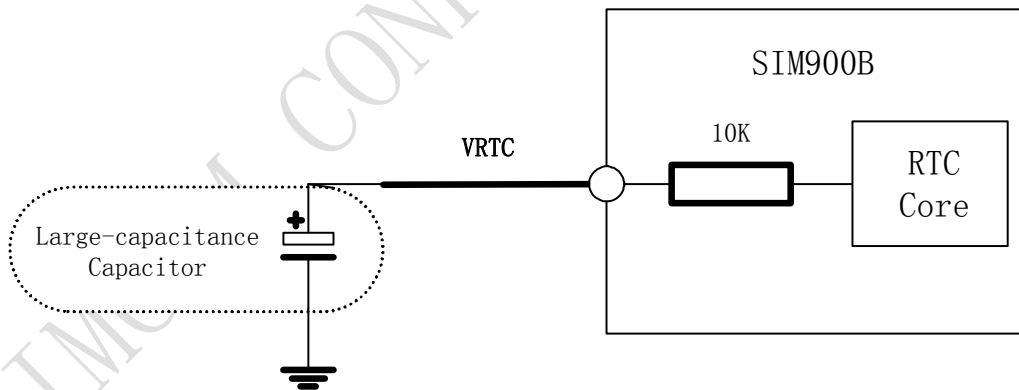

Figure 14: RTC supply from capacitor

- **Li-battery backup**

Coin-type Rechargeable Capacitor such as XH414H-IV01E from Seiko can be used.

Typical charge curves for each cell type are shown in following figures. Note that the rechargeable Lithium type coin cells generally come pre-charged from the vendor.

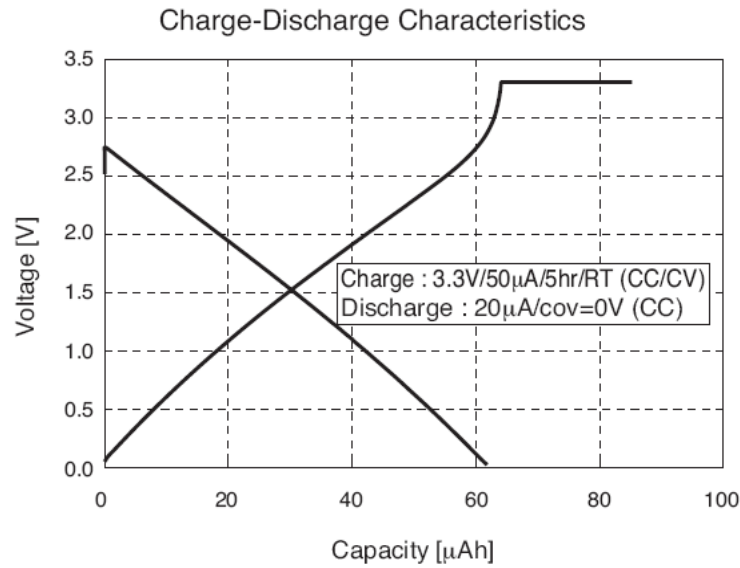

Figure 15: Seiko XH414H-IV01E Charge -Discharge Characteristic

3.7 Serial Interfaces

Table 8: Pin definition of the serial interfaces

	Name	Pin	Function
Serial port	DCD	28	Data carrier detection
	DTR	38	Data terminal ready
	RXD	40	Receive data
	TXD	42	Transmit data
	RTS	44	Request to send
	CTS	46	Clear to send
	RI	48	Ring indicator
Debug port	DBG_RXD	47	Receive data
	DBG_TXD	49	Transmit data

SIM900B provides two unbalanced asynchronous serial ports. One is the serial port and the other is the debug port. The GSM module is designed as a DCE (Data Communication Equipment), following the traditional DCE-DTE (Data Terminal Equipment) connection. The module and the client (DTE) are connected through the following

SIM900B Hardware Design

signal (as following figure shows). Autobauding supports baud rate from 1200bps to 57600bps.

Serial port

- TXD: Send data to the RXD signal line of the DTE
- RXD: Receive data from the TXD signal line of the DTE

Debug port

- DBG_TXD: Send data to the RXD signal line of the DTE
- DBG_RXD: Receive data from the TXD signal line of the DTE

The logic levels are described in following table.

Table 9: Logic levels of the serial port and debug port

Parameter	Min	Max	Unit
V_{IL}	0	$0.15 * V_{DD_EXT}$	V
V_{IH}	$0.85 * V_{DD_EXT}$	V_{DD_EXT}	V
V_{OL}	0	0.1	V
V_{OH}	$V_{DD_EXT} - 0.1$	V_{DD_EXT}	V

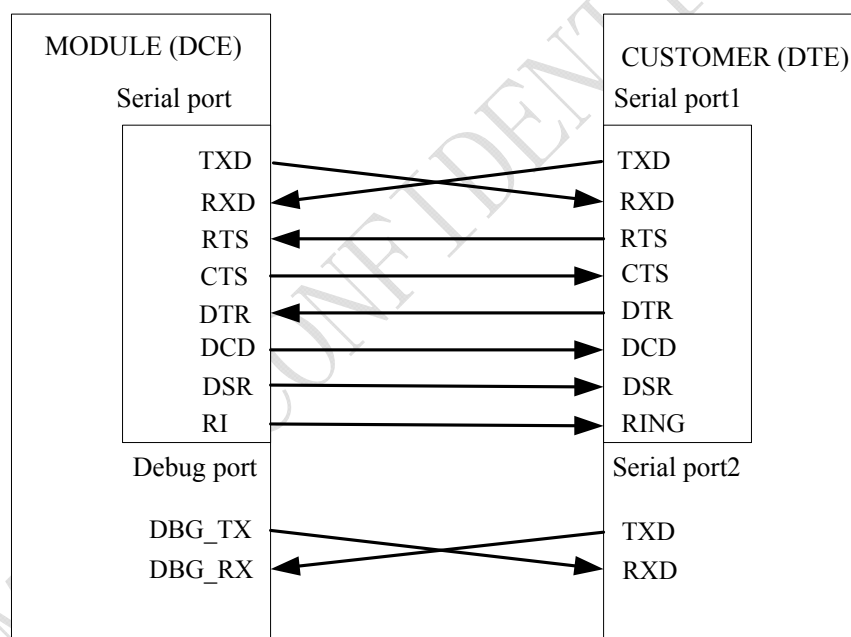

Figure 16: Connection of the serial interfaces

3.7.1 Function of serial port & debug port supporting

Serial port

- Modem device.
- Contains data lines TXD and RXD, State lines RTS and CTS, Control lines DTR, DCD and RI.
- Serial port can be used for CSD FAX, GPRS service and send AT command of controlling module. Also

SIM900B Hardware Design

serial port can be used for multiplexing function. SIM900B supports only basic mode of multiplexing so far.

- Serial port supports the communication rates as following:
1200, 2400, 4800, 9600, 19200, 38400, 57600 and 115200bps.
- Autobauding supports baud rates as following:
1200, 2400, 4800, 9600, 19200, 38400, and 57600bps, the default setting is autobauding.

Autobauding allows the GSM engine to automatically detect the baud rate configured in the host application. The serial port of the GSM engine supports autobauding for the following baud rates: 1200, 2400, 4800, 9600, 19200, 38400, 57600bps. Factory setting is autobauding enabled. This gives user the flexibility to put the GSM engine into operation no matter what baud rate the host application is configured to. To take advantage of autobauding mode, specific attention should be paid to the following requirements:

Synchronization between DTE and DCE:

When DCE powers on with the autobauding enabled, user must first send “A” to synchronize the baud rate. It is recommended to wait 2 to 3 seconds before sending “AT” character. After receiving the “OK” response, DTE and DCE are correctly synchronized. The more information please refer to the AT command “AT+IPR”.

Restrictions on autobauding operation

- The serial port has to be operated at 8 data bits, no parity and 1 stop bit (factory setting).
- The Unsolicited Result Codes like "RDY", "+CFUN: 1" and "+CPIN: READY" are not indicated when user start up the ME while autobauding is enabled. This is due to the fact that the new baud rate is not detected unless DTE and DCE are correctly synchronized as described above.

Note: use “AT+IPR=x” to set a fixed baud rate and save the configuration to non-volatile flash memory. After the configuration is saved as fixed baud rate, the Unsolicited Result Codes like "RDY" should be received from the serial port all the time that the SIM900B is power on.

Debug port

- Only contain Data lines TXD and RXD
- Debug Port used for debugging and upgrading firmware. It cannot be used for CSD call, FAX call. And the Debug port can not use multiplexing function. It does not support autobauding function.
- Debug port supports the communication rates is 115200bps

3.7.2 Software Upgrade and Software Debug

The DBG_TXD, DBG_RXD and GND must be connected to the IO connector when user need to upgrade software and debug software, the DBG_TXD, DBG_RXD should be used for software upgrade and for software debugging. The TXD and RXD also should be connected to the IO connector, if user wants to send AT command or data stream to SIM900B. The PWRKEY pin is recommended to connect to the IO connector. The user also can add a switch between the PWRKEY and the GND. The PWRKEY should be connected to the GND when SIM900B is upgrading software. Please refer to the following figure.

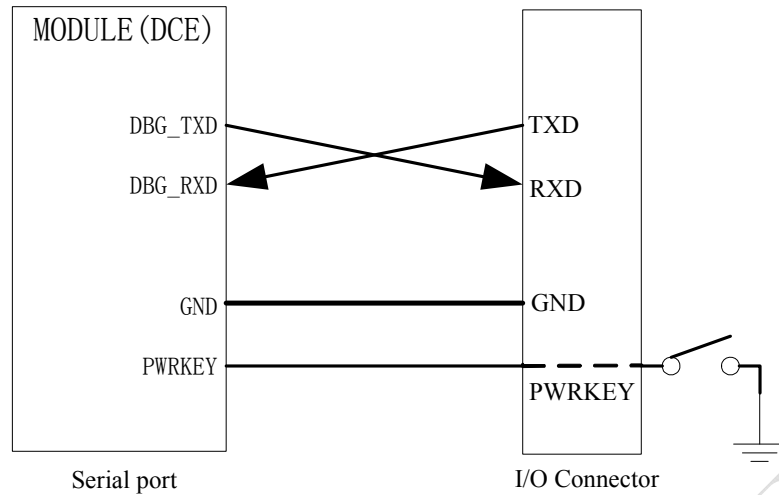

Figure 17: Connection of software upgrade and software debug

The serial port and the debug port does not support the RS_232 level and it only supports the CMOS level. Please refer to the table 10 for details about the voltage level. User should add the level converter IC between the DCE and DTE, if user connect it to the computer. Please refer to the following figure

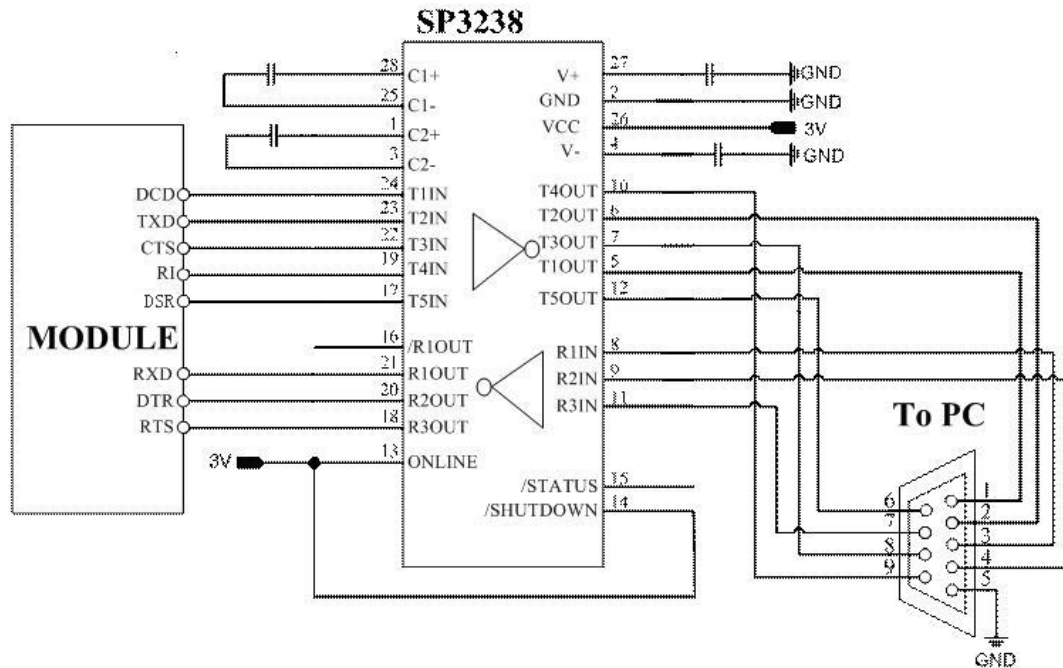

Figure 18: RS232 level converter circuit

3.8 Audio Interfaces

Table 10: Pin definition of the Audio interface

	Name	Pin	Function
(AIN1/AOUT1)	MIC1P	53	Microphone1 input +
	MIC1N	55	Microphone1 input -
	SPK1P	54	Audio1 output+
	SPK1N	56	Audio1 output-
(AIN2/AOUT2)	MIC2P	57	Microphone2 input +
	MIC2N	59	Microphone2 input -
	SPK2P	58	Audio2 output+
	SPK2N	60	Audio2 output-

The module provides two analog input channels, AIN1 and AIN2, which may be used for both microphone and line inputs. The electret microphone is recommended when the interface is used for microphone. One of the two channels is typically used with a microphone built into a handset. The other channel is typically used with an external microphone or external line input. The module analog input configuration is determined by control register settings and established using analog multiplexes.

For each channels, “AT+CMIC” can be used to adjust the input gain level of microphone, “AT+SIDET” can be used to set the side-tone level. In addition, “AT+CLVL” can be used to adjust the output gain level of both receiver and speaker at the same time, use AT+CHFA to activate one of the two audio channels and deactivate the other one.. For more details, please refer to *document [1]*.

Note: Use AT command AT+CHFA to select audio channel:

0— AIN1/AOUT1 (normal audio channel), the default value is 0.

1— AIN2/AOUT2(aux_audio channel) .

It is suggested that user adopt one of the following two matching circuits in order to improve audio performance. The difference audio signals have to be layout according to difference signal layout rules. As show in following figures (**Note: all components package are 0603.**) If an amplifier circuit for audio is needed, then National company’s LM4890 is recommended. Of course it can select it according to user’s requirement.

3.8.1 Speaker Interface Configuration

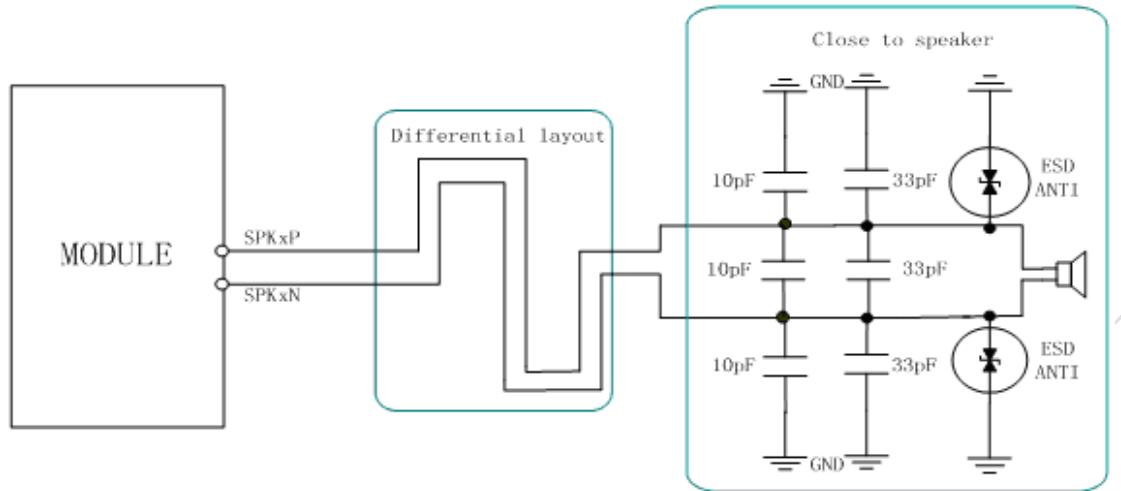

Figure 19: Speaker interface configuration

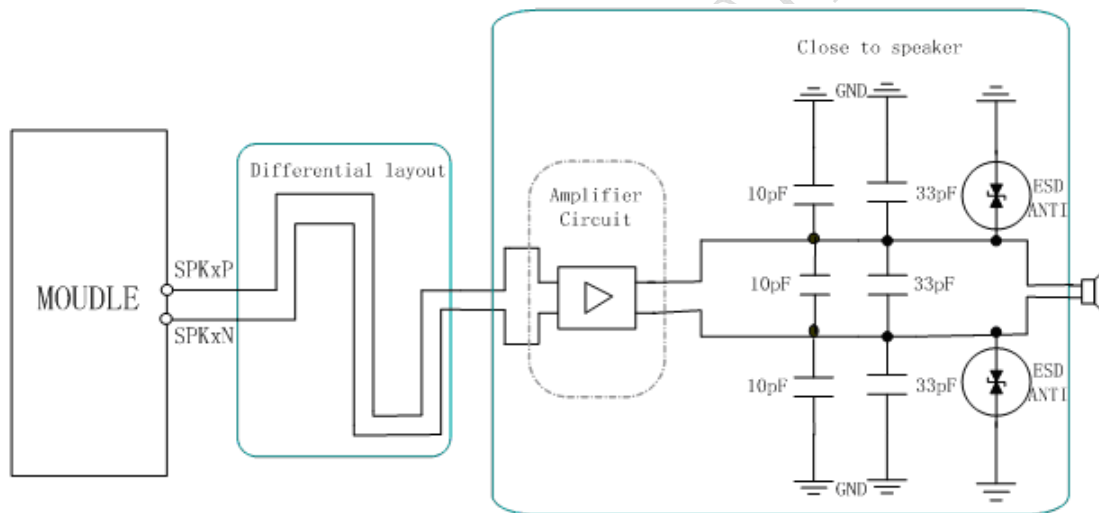

Figure 20: Speaker interface with amplifier configuration

3.8.2 Microphone Interfaces Configuration

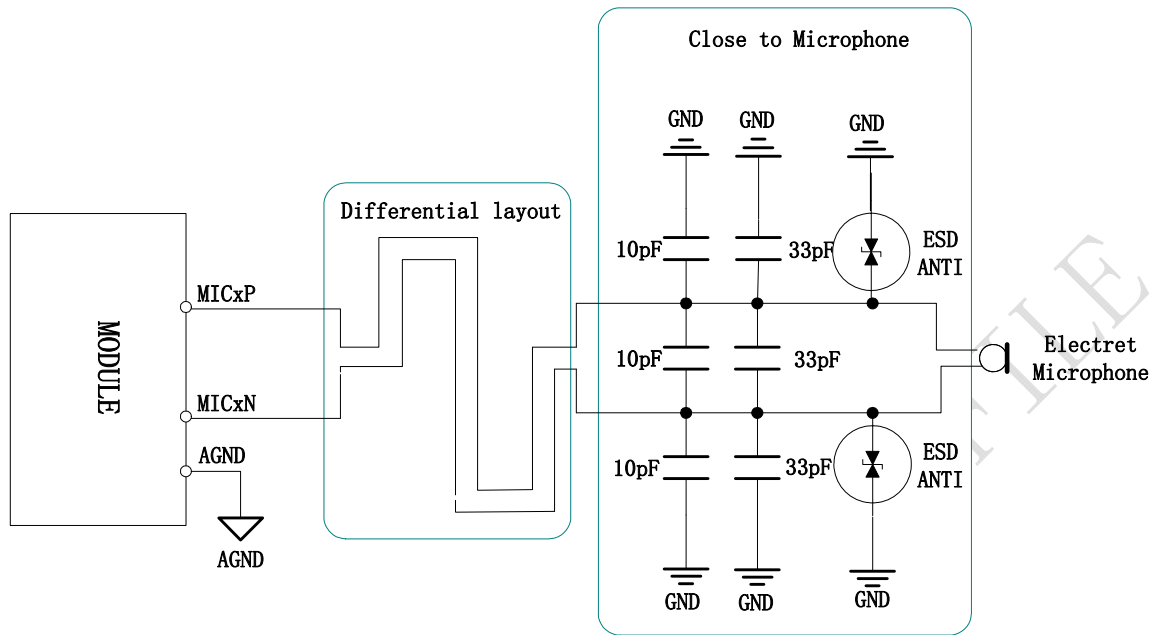

Figure 21: Microphone interface configuration

3.8.3 Earphone Interface Configuration

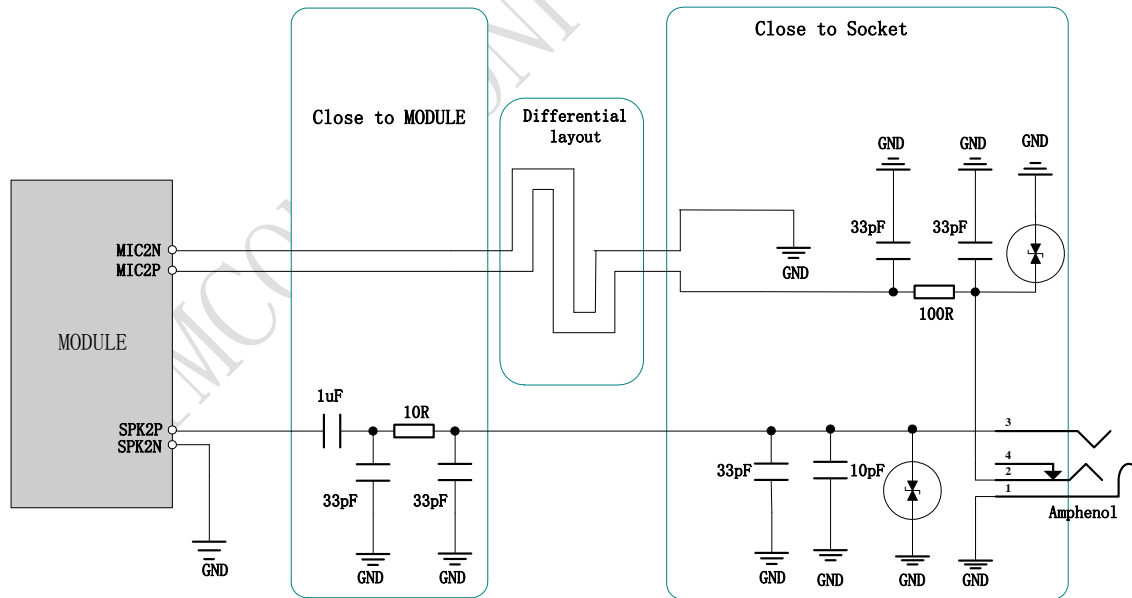

Figure 22: Earphone interface configuration

3.8.4 Referenced Electronic Characteristic

Table 11: MIC Input Characteristics

Parameter	Min	Typ	Max	Unit
Working Voltage	1.2	1.5	2.0	V
Working Current	200		500	uA
External Microphone Load Resistance	1.2	2.2		k Ohms
Internal biasing DC Characteristics			2.5	V
Differential input voltage	THD <1% at F=1KHz; pre-amp gain = 20 dB; PGA gain = 14 dB		15.9	mVrms
	THD <5% at F=1KHz; pre-amp gain = 0 dB; PGA gain = 0 dB		740	mVrms

Table 12: Audio Output Characteristics

Parameter	Conditions	Min	Typ	Max	Unit
Normal Output(SPK1P/1N)	load Resistance	27	32	-	Ohm
	Biasing voltage		1.4		V
	Output swing Voltage(single)			1.1V	V _{pp}
	Output swing Voltage(differential)			2.2	V _{pp}
	RL=32 Ohm THD=0.1%	-	91	-	mW
	RL=32 Ohm THD=1%	-	96	-	mW
Normal Output(SPK2P/2N)	load Resistance	27	32	-	Ohm
	Biasing voltage		1.4		V
	Output swing Voltage(single)			1.1V	V

SIM900B Hardware Design

	Output swing Voltage(differential)			2.2	V
	RL=32 Ohm THD=0.1%	-	91	-	mW
	RL=32 Ohm THD=1%	-	96	-	mW

3.9 Buzzer

The BUZZER on the board-to-board connector can be used to drive a buzzer to indicate incoming call. The output volume of buzzer can be set by “AT+CRSL”. The reference circuit for buzzer shown as following figure:

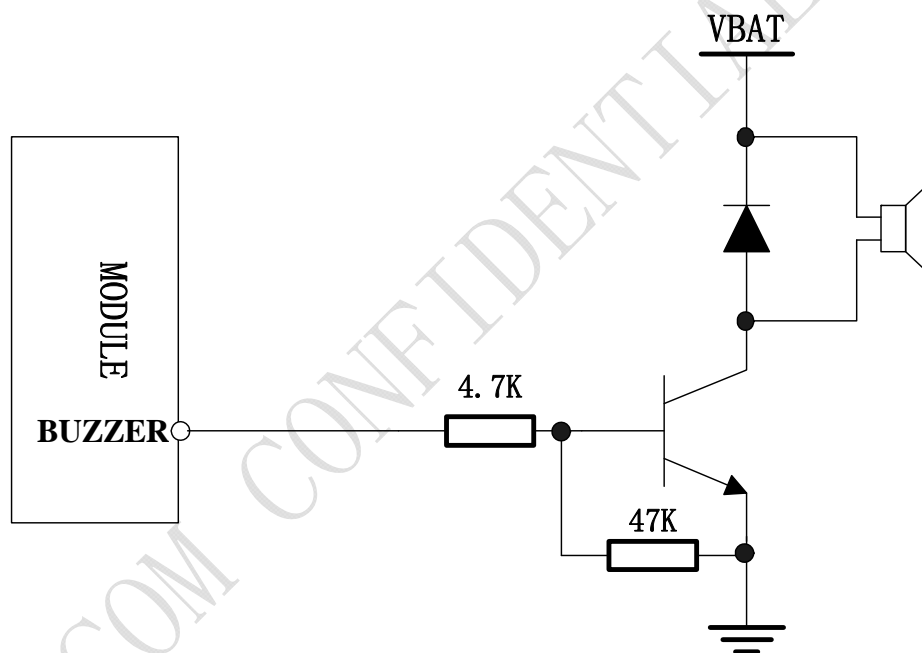

Figure 23: Reference circuit of Buzzer

Table 13: Buzzer Output Characteristics

Parameter	Min	Typ	Max	Unit
Working Voltage	2.4	2.85	3.0	V
Working Current		2		mA
Load Resistance	1			k Ohms

3.10 SIM Card Interface

3.10.1 SIM Card Application

User can use AT Command to get information in SIM card. For more information, please refer to *document [1]*.

The SIM interface supports the functionality of the GSM Phase 1 specification and also supports the functionality of the new GSM Phase 2+ specification for FAST 64 kbps SIM (intended for use with a SIM application Tool-kit).

Both 1.8V and 3.0V SIM Cards are supported.

The SIM interface is powered from an internal regulator in the module. All pins are described in the following table.

Table 14: Pin definition of the SIM interface

Name	Pin	Function
SIM_VDD	19	SIM Card Power output automatic output on SIM mode, one is 3.0V±10%, another is 1.8V±10%. Current is about 10mA.
SIM_DATA	21	SIM Card data I/O
SIM_CLK	23	SIM Card Clock
SIM_RST	25	SIM Card Reset
SIM_PRESENCE	16	SIM Card Presence

Following figure is the reference circuit for SIM interface. SIMCom recommend an Electro-Static discharge device ST (www.st.com) ESDA6V1W5 or ON SEMI (www.onsemi.com) SMF05C for “ESD ANTI”. The 22Ω resistors showed in the following figure should be added in series on the IO line between the module and the SIM card for protecting the SIM I/O port. The pull up resistor (about 15KΩ) on the SIM_DATA line already added in the module. Note that the SIM peripheral circuit should be close to the SIM card socket.

The SIM_PRESENCE pin is used for detecting the SIM card insert or removal. User can use the AT command “AT+CSDT” to switching on or off SIM card detection function. For detail of this AT command, please refer to *document [1]*:

User can select the 8-pin SIM card holder to implement SIM card detection function. The reference circuit of the 8-pin SIM card holder is illustrated as following figure

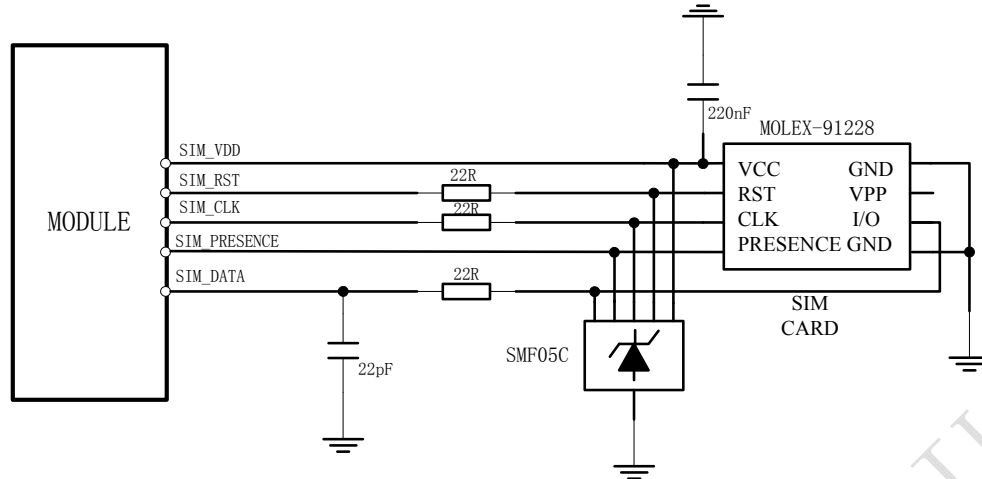

Figure 24: Reference circuit of the 8 pins SIM card holder

If user do not use the SIM card detection function, user can leave the SIM_PRESENCE pin open. The reference circuit of 6-pin SIM card is illustrated as following figure.

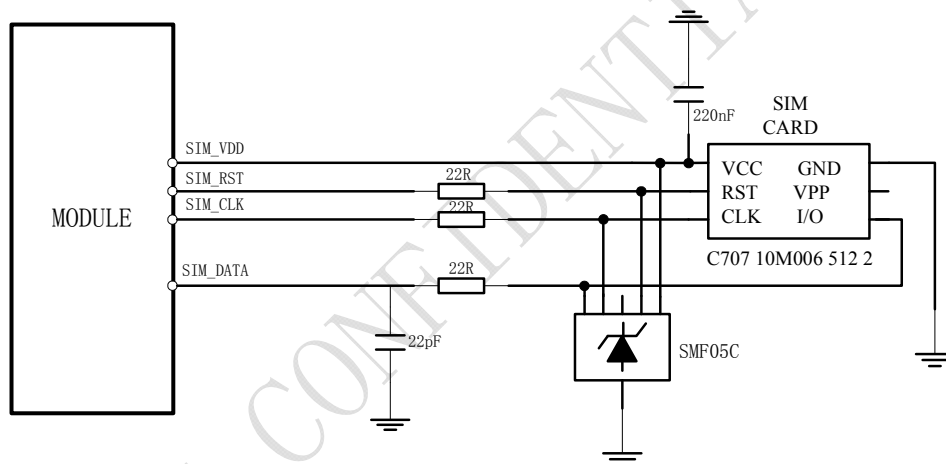

Figure 25: Reference circuit of the 6 pins SIM card holder

3.10.2 Design Considerations for SIM Card Holder

For 6 pins SIM card holder, SIMCom recommend to use Amphenol C707 10M006 512 2, the user can visit <http://www.amphenol.com> for more information about the holder.

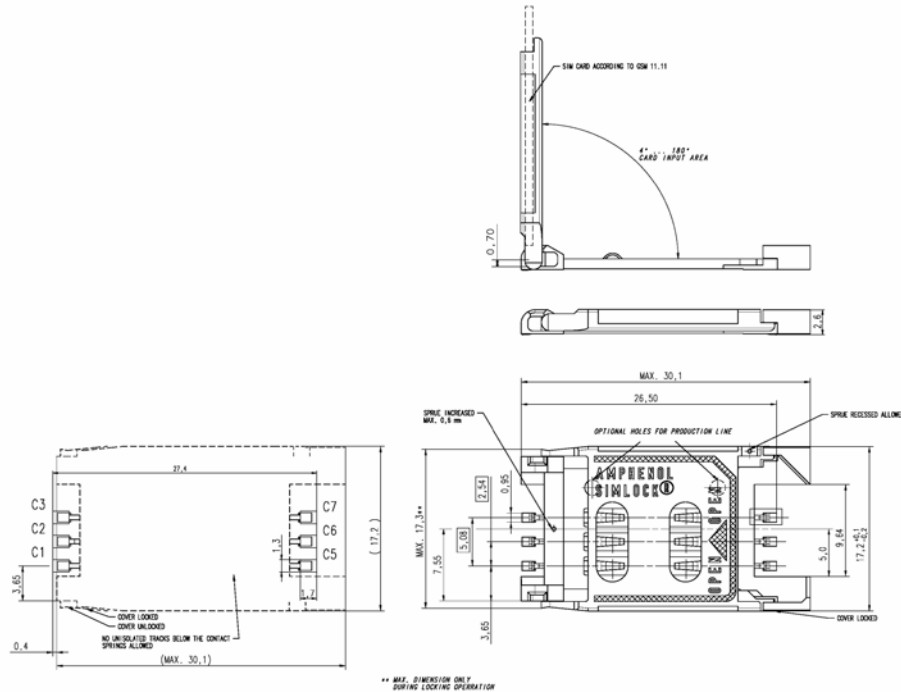

Figure 26: Amphenol C707 10M006 512 2 SIM card holder

Table 15: Pin description (Amphenol SIM card holder)

Pin Name	Signal	Description
C1	SIM_VDD	SIM Card Power supply, it can identify automatically the SIM Card power mode, one is 3.0V±10%, another is 1.8V±10%. Current is about 10mA.
C2	SIM_RST	SIM Card Reset.
C3	SIM_CLK	SIM Card Clock.
C5	GND	Connect to GND.
C6	VPP	Not connect.
C7	SIM_DATA	SIM Card data I/O.

For 8 pins SIM card holder, Molex 91228 is recommended. User can visit <http://www.molex.com> for more information about the holder.

3.11 LCD Display Interface

SIM900B provides a serial LCD display interface that supports serial communication with LCD device. When used as LCD interface, the following table is the pin definition. LCD interface timing should be united with the LCD device.

Table 17: Pin definition of the LCD interface

Name	Pin	Function
DISP_DATA	18	Display data output
DISP_CLK	20	Display clock for LCD
DISP_CS	22	Display enable
DISP_D/C	24	Display data or command select
DISP_RST	26	LCD reset

Note: This function is not supported in the default firmware. There must be some customized firmware if user want. Please contact SIMCom for more details.

3.12 Keypad Interface

The keypad interface consists of 5 keypad column outputs and 4 keypad row inputs. The basic configuration is 5 keypad columns and 4 keypad rows, giving 20 keys.

Table 18: Pin definition of the keypad interface

Name	Pin	Function
GPIO5/KBC0	27	Keypad matrix column
GPIO4/KBC1	29	
GPIO3/KBC2	31	
GPIO2/KBC3	33	
GPIO1/KBC4	35	
GPIO9/KBR1	39	Keypad matrix row
GPIO8/KBR2	41	
GPIO7/KBR3	43	
GPIO6/KBR4	45	

The keypad interface allows a direct external matrix connection. A typical recommended circuit of the keypad is as shown in the following figure.

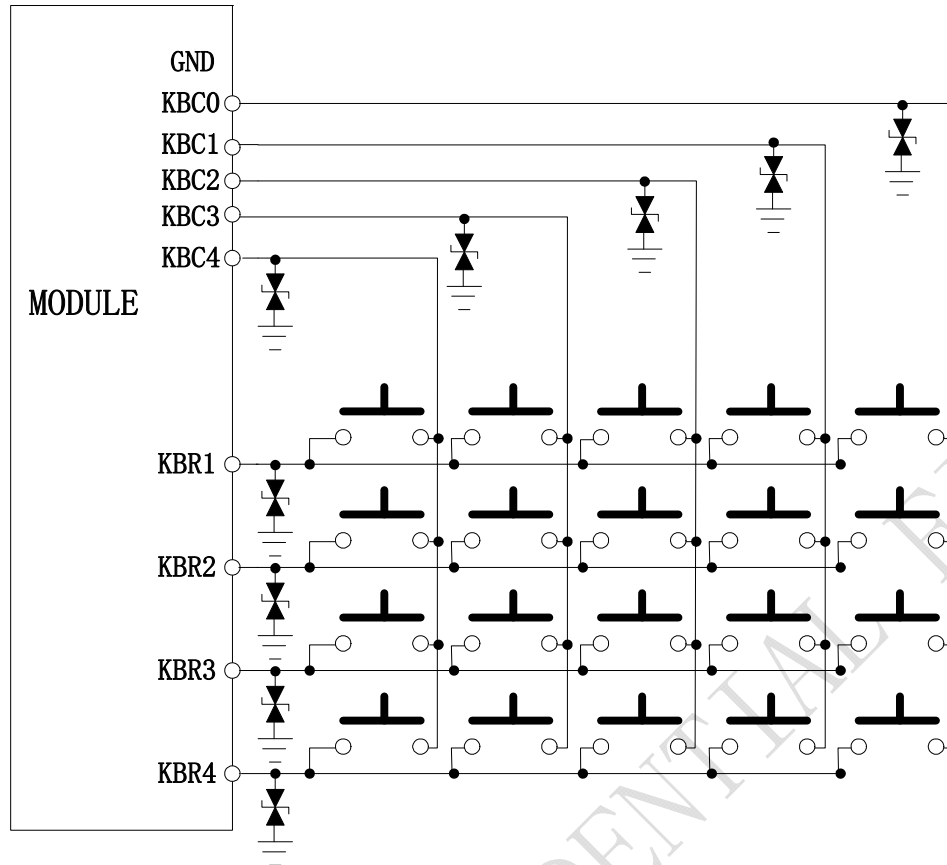

Figure 28: Reference circuit of the keypad interface

***Note:**

1. This function is not supported in the default firmware. There must be customized firmware if user want. Please contact SIMCom for more details.
2. KBR0&KBC0 are used to power off the module, so user do not connect them for other applications.
3. keypad is the second function of these pins , the default function is GPIO.

3.13 ADC

SIM900B provides one auxiliary ADC (General purpose analog to digital converter.) as voltage input pin, which can be used to detect the values of some external items such as voltage, temperature etc. User can use AT command “AT+CADC” to read the voltage value on ADC. For detail of this AT command, please refer to document [1].

Table 19: ADC specification

	MIN	Type	MAX	Units
Voltage range	0	-	2.8	V
ADC Resolution	-	10	-	bits
Sampling rate	-	-	200K	Hz

3.14 Behaviors of the RI

Table 20: Behaviours of the RI

State	RI respond
Standby	HIGH
Voice call	Change LOW, then: (1) Change to HIGH when establish the call. (2) Use AT command ATH, the RI pin changes to HIGH. (3) Sender hangs up, change to HIGH.
Data call	Change LOW, then: (1) Change to HIGH when establish the call. (2) Use AT command ATH, the RI changes to HIGH.
SMS	Change to low and hold low level about 120 ms when receive a SMS,, then change to HIGH.
URC	Some URCs triggers 120ms low level on RI. <i>For more details, please refer to document [10]</i>

If the module is used as caller, the RI will maintain high. However, when it is used as receiver, following is timing of ring.

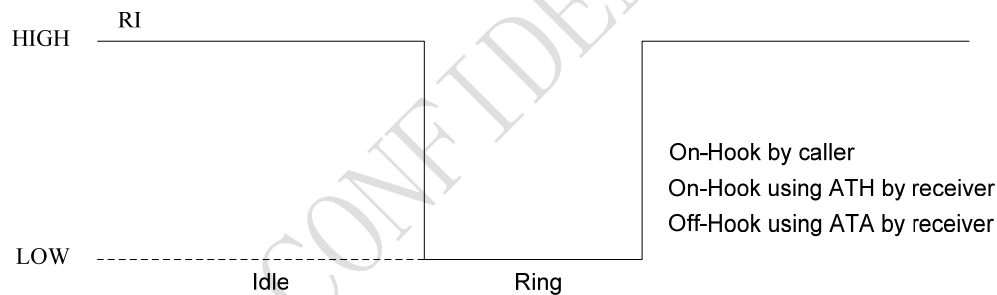

Figure 29: RI behaviour of voice call as a receiver

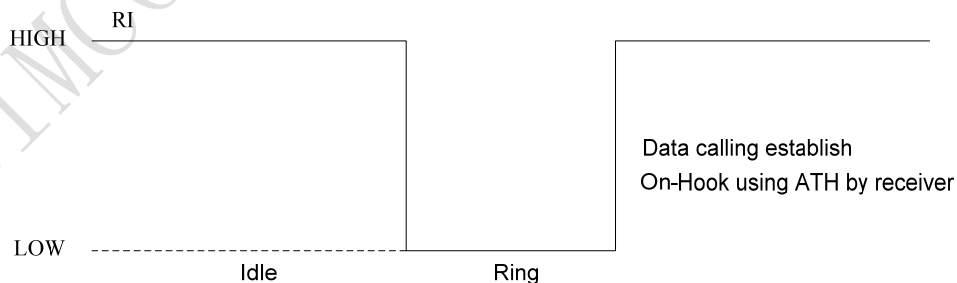

Figure 30: RI behaviour of data call as a receiver

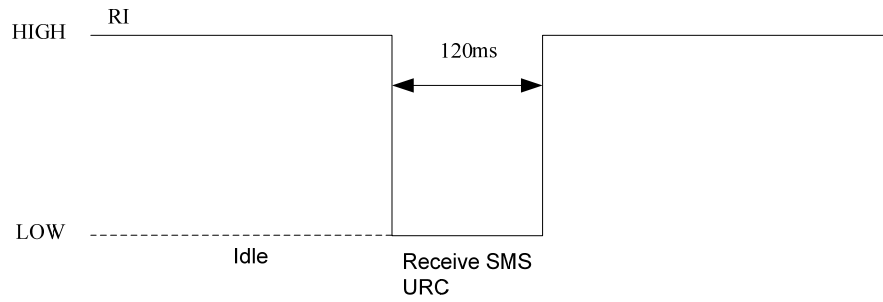

Figure 31: RI behaviour of URC or receive SMS

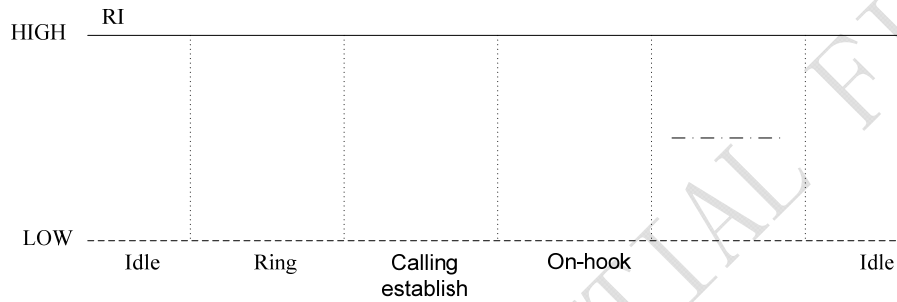

Figure 32: RI behaviour as a caller

3.15 Network Status Indication

The NETLIGHT can be used to drive a network status indication LED lamp. The working state of this pin is listed in following table:

Table 21: Working state of the NETLIGHT

State	SIM900B function
Off	SIM900B is not running
64ms On/ 800ms Off	SIM900B does not find the network
64ms On/ 3000ms Off	SIM900B finds the network
64ms On/ 300ms Off	GPRS communication

The reference circuit is shown as the following figure:

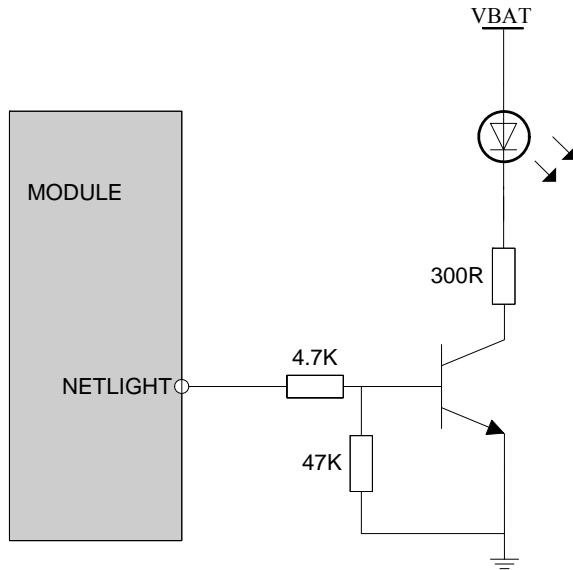

Figure 33: Reference circuit of NETLIGHT

3.16 General Purpose Input Output (GPIO)

SIM900B provides a limited number of General Purpose Input/Output signal pin.

Table 22: Pin definition of the GPIO interface

Name	Pin	Default function	Second Function	Default state
GPIO0	32	GPIO0		Input pull down
GPIO1/KBC4	35	GPIO1	KBC4	Input pull down
GPIO2/KBC3	33	GPIO2	KBC3	Input pull down
GPIO3/KBC2	31	GPIO3	KBC2	Input pull down
GPIO4/KBC1	29	GPIO4	KBC1	Input pull down
GPIO5/KBC0	27	GPIO5	KBC0	Input pull down
GPIO6/KBR4	45	GPIO6	KBR4	Input pull down
GPIO7/KBR3	43	GPIO7	KBR3	Input pull down
GPIO8/KBR2	41	GPIO8	KBR2	Input pull down
GPIO9/KBR1	39	GPIO9	KBR1	Input pull down
GPIO10/KBR0	37	GPIO10		Input pull down

Note: This function is not supported in the default firmware. There must be special firmware if user want. Please contact SIMCom for more details .

4 Antenna Interface

The RF interface has an impedance of 50Ω. To suit the physical design of individual applications, SIM900B offers alternatives

- Recommended approach: antenna connector on the component side of the PCB
- Antenna pad and grounding plane placed on the bottom side.

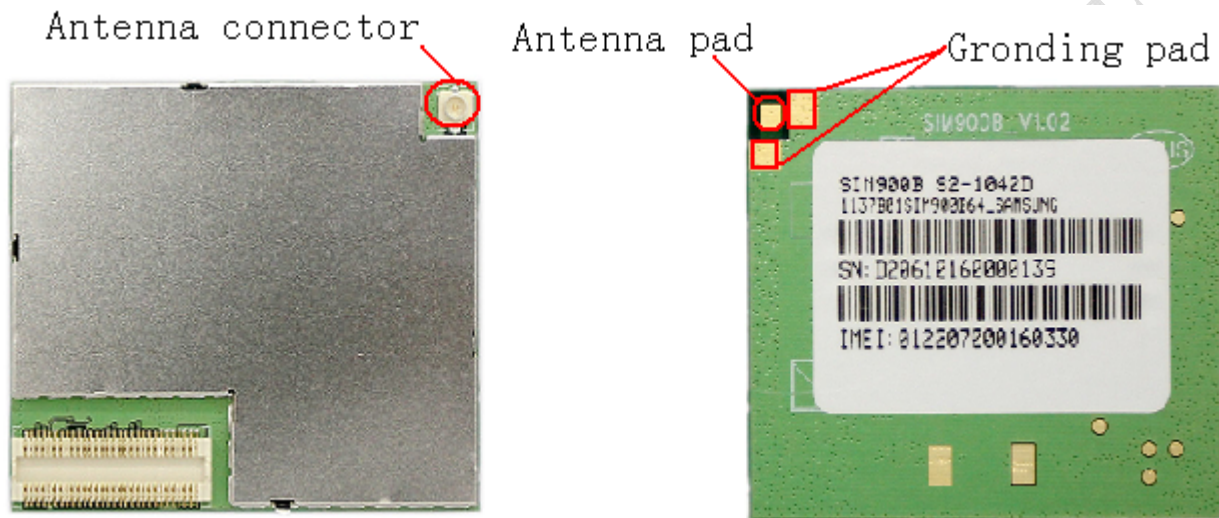

Figure 34 : The RF interface of module

The antenna can be soldered to the pad, or attached via contact springs. To help user to ground the antenna, SIM900B comes with a grounding plane located close to the antenna pad.

SIM900B material properties:

SIM900B PCB Material: FR4

Antenna pad: Gold plated pad

To minimize the loss on the RF cable, it need be very careful to choose RF cable. SIMCom recommend the insertion loss should be meet following requirements:

- GSM900<1dB
- DCS1800/PCS1900<1.5dB

4.1 Module RF Output Power

Table 23: SIM900B conducted RF output power

Frequency	Max	Min
GSM850	33dBm ±2db	5dBm±5db
EGSM900	33dBm ±2db	5dBm±5db
DCS1800	30dBm ±2db	0dBm±5db
PCS1900	30dBm ±2db	0dBm±5db

4.2 Module RF Receive Sensitivity

Table 24: SIM900B conducted RF receive sensitivity

Frequency	Receive sensitivity (Typical)	Receive sensitivity(Max)
GSM850	-109dBm	-107dBm
EGSM900	-109dBm	-107dBm
DCS1800	-109dBm	-107dBm
PCS1900	-109dBm	-107dBm

4.3 Module Operating Frequencies

Table 25: SIM900B operating frequencies

Frequency	Receive	Transmit
GSM850	869 ~ 894MHz	824 ~ 849 MHz
EGSM900	925 ~ 960MHz	880 ~ 915MHz
DCS1800	1805 ~ 1880MHz	1710 ~ 1785MHz
PCS1900	1930 ~ 1990MHz	1850 ~ 1910MHz

5 Electrical, Reliability and Radio Characteristics

5.1 Absolute Maximum Ratings

The absolute maximum ratings stated in Table 28 are stress ratings under non-operating conditions. Stresses beyond any of these limits will cause permanent damage to SIM900B.

Table 26: Absolute maximum ratings

Parameter	Min	Max	Unit
V _{BAT}	-	5.5	V
Peak current of power supply	0	3.0	A
Voltage at digit pins*	-0.3	3.1	V
I _I *	-	10	mA
I _O *	-	10	mA

*For digital interface pins, such as keypad, GPIO, UART and LCD.

5.2 Operating Temperatures

The operating temperature is listed in following table:

Table 27: SIM900B operating temperature

Parameter	Min	Typ	Max	Unit
Ambient temperature	-30	+25	+80	°C
Restricted operation*	-40 to -30		+80 to +85	°C
Storage temperature	-45		+90	°C

* The SIM900B does work, but deviations from the GSM specification may occur.

5.3 Power Supply Ratings

Table 28: SIM900B power supply ratings

Parameter	Description	Conditions	Min	Typ	Max	Unit
V _{BAT}	Supply voltage	Voltage must stay within the min/max values, including voltage drop, ripple, and spikes.	3.2	4.0	4.8	V
	Voltage drop during transmit burst	Normal condition, power control level for Pout max			300	mV

SIM900B Hardware Design

	Voltage ripple	Normal condition, power control level for Pout max @ f<200kHz @ f>200kHz			50 2	mV				
I _{VBAT}	Average supply current	POWER DOWN mode		50		uA				
		SLEEP mode(BS-PA-MFRMS=2)		1.5		mA				
		(BS-PA-MFRMS=5)		1.2		mA				
		(BS-PA-MFRMS=9)		1.0		mA				
		IDLE mode								
		GSM 850		22						
		EGSM 900		22			mA			
DCS1800		22								
PCS1900		22								
TALK mode	GSM 850	EGSM 900	DCS1800	PCS1900		mA				
							235			
							247			
							181			
DATA mode, GPRS (3 Rx,2Tx)	GSM 850	EGSM 900	DCS1800	PCS1900		mA				
							436			
							463			
							322			
DATA mode, GPRS (4 Rx,1Tx)	GSM 850	EGSM 900	DCS1800	PCS1900		mA				
							270			
							282			
							215			
Peak supply current (during Tx burst)		Power control level for Pout max.		2.0		A				

5.4 Current Consumption

Please refer to the following table for the values of current consumption.

Table 29: SIM900B current consumption (VBAT=3.8V)

Voice Call	
GSM 850/EGSM 900	@power level #5 <300mA, Typical 250mA @power level #12, Typical 110mA @power level #19, Typical 80mA
DCS 1800/PCS 1900	@power level #0 <200mA, Typical 180mA @power level #7, Typical 94mA @power level #15, Typical 76mA
GPRS Data	
DATA mode, GPRS (1 Rx,1 Tx) CLASS 8	
GSM 850/EGSM 900	@power level #5 <300mA, Typical 235mA @power level #12, Typical 102mA @power level #19, Typical 74mA
DCS 1800/PCS 1900	@power level #0 <200mA, Typical 170mA @power level #7, Typical 90mA @power level #15, Typical 70mA
DATA mode, GPRS (3 Rx, 2 Tx) CLASS 10	
GSM 850/EGSM 900	@power level #5 <450mA, Typical 440mA @power level #12, Typical 185mA @power level #19, Typical 125mA
DCS 1800/PCS 1900	@power level #0 <350mA, Typical 320mA @power level #7, Typical 155mA @power level #15, Typical 120mA
DATA mode, GPRS (4 Rx,1 Tx) CLASS 8	
GSM 850/EGSM 900	@power level #5 <300mA, Typical 273mA @power level #12, Typical 145mA @power level #19, Typical 120mA
DCS 1800/PCS 1900	@power level #0 <300mA, Typical 205mA @power level #7, Typical 130mA @power level #15, Typical 110mA

Class 10 is default set when the module works at data translation mode, the module can also work at class 8 set by AT command.

5.5 Electro-Static Discharge

The GSM engine is not protected against Electrostatic Discharge (ESD) in general. Therefore, it is subject to ESD handling precautions that typically apply to ESD sensitive components. Proper ESD handling and packaging procedures must be applied throughout the processing, handling and operation of any application using a SIM900B module.

The measured values of SIM900B are shown as the following table:

Table 30: The ESD endure statue measured table (Temperature: 25°C, Humidity:45%)

Part	Contact discharge	Air discharge
VBAT	±5KV	±10KV
GND	±5KV	±10KV
RXD, TXD	±2KV	±8KV
Antenna port	±5KV	±10KV
SPK_P/N MIC_P/N	±2KV	±5KV
PWRKEY	±2KV	±8KV
Other port	TBD	TBD

6 Mechanics

This chapter describes the mechanical dimensions of SIM900B.

6.1 Mechanical Dimensions of SIM900B

Following shows the Mechanical dimensions of SIM900B (top view, side view and bottom view).

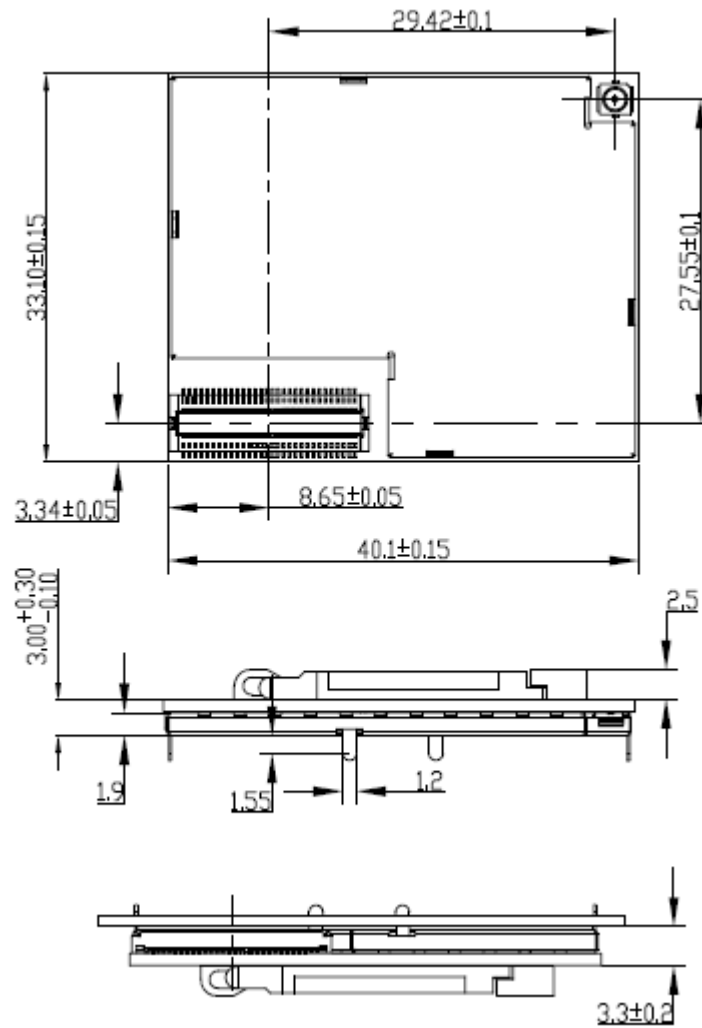

Figure 35: Top and Side Mechanical dimensions of module (Unit: mm)

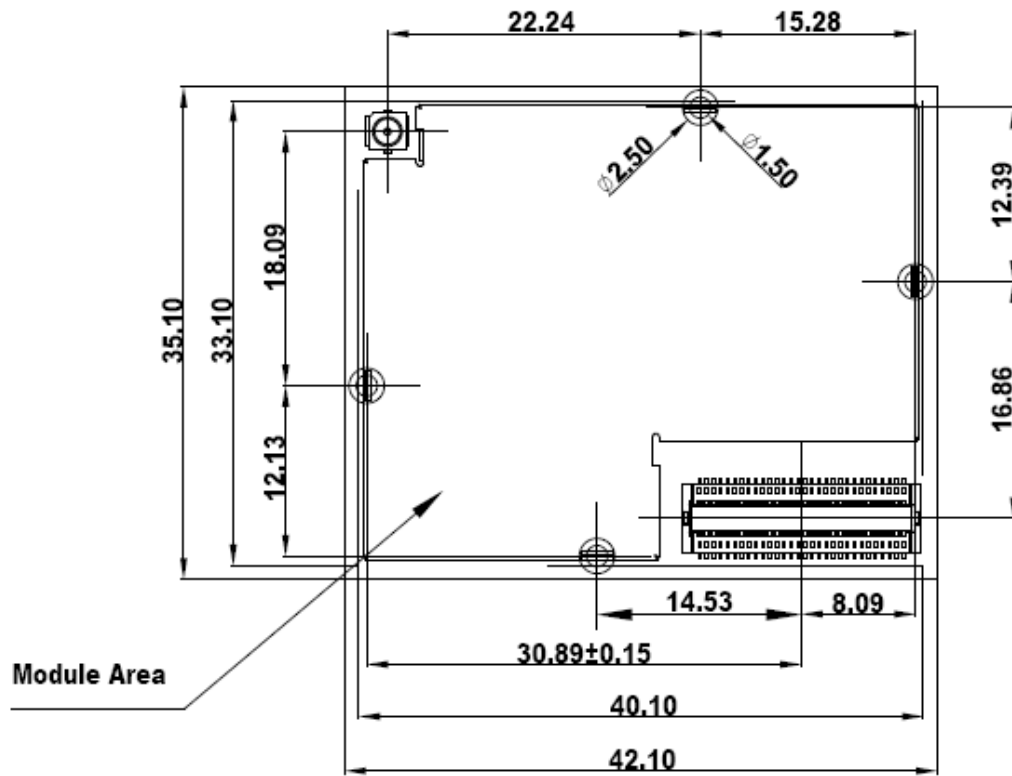

Figure 36: Mechanical dimensions of module PCB decal (Unit: mm)

6.2 Top View of the SIM900B

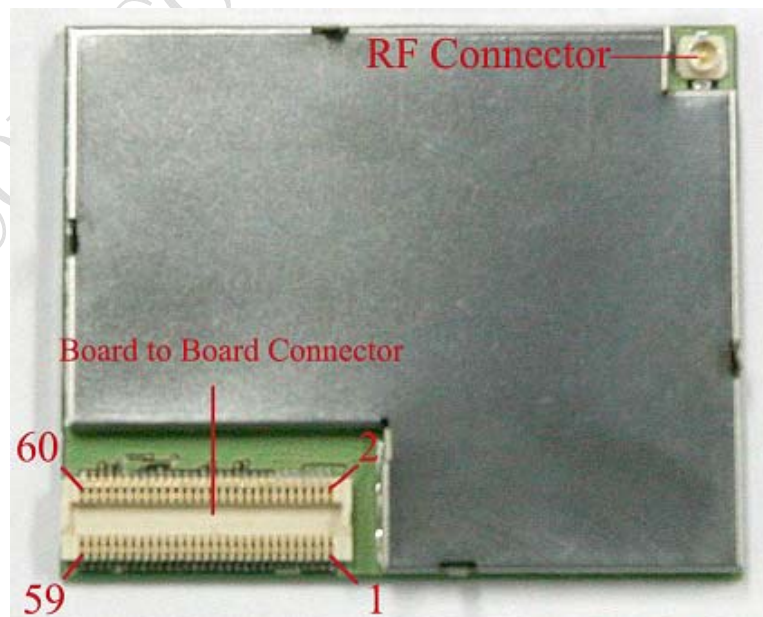

Figure 37: Top view of the SIM900B

6.3 Mounting SIM900B onto the application platform

Use the connector BB530-06001-20R to fix the SIM900B onto the customer platform

6.4 Board-to-board connector

SIMCom recommend to use RUNFENG Company’s BB530-06001-20R as the board-to-board connector. They are fully compatible each other. This high density SMT connector is designed for parallel PCB-to-PCB applications. It is ideal to use in VCRs, notebook PCs, cordless telephones, mobile phones, audio/visual and other telecommunications equipment where reduced size and weight are important. Following is parameter of BB530-06001-20R. User can connect SIMCom for more information.

6.4.1 Mechanical dimensions of the RUNFENG BB530-06001-20R

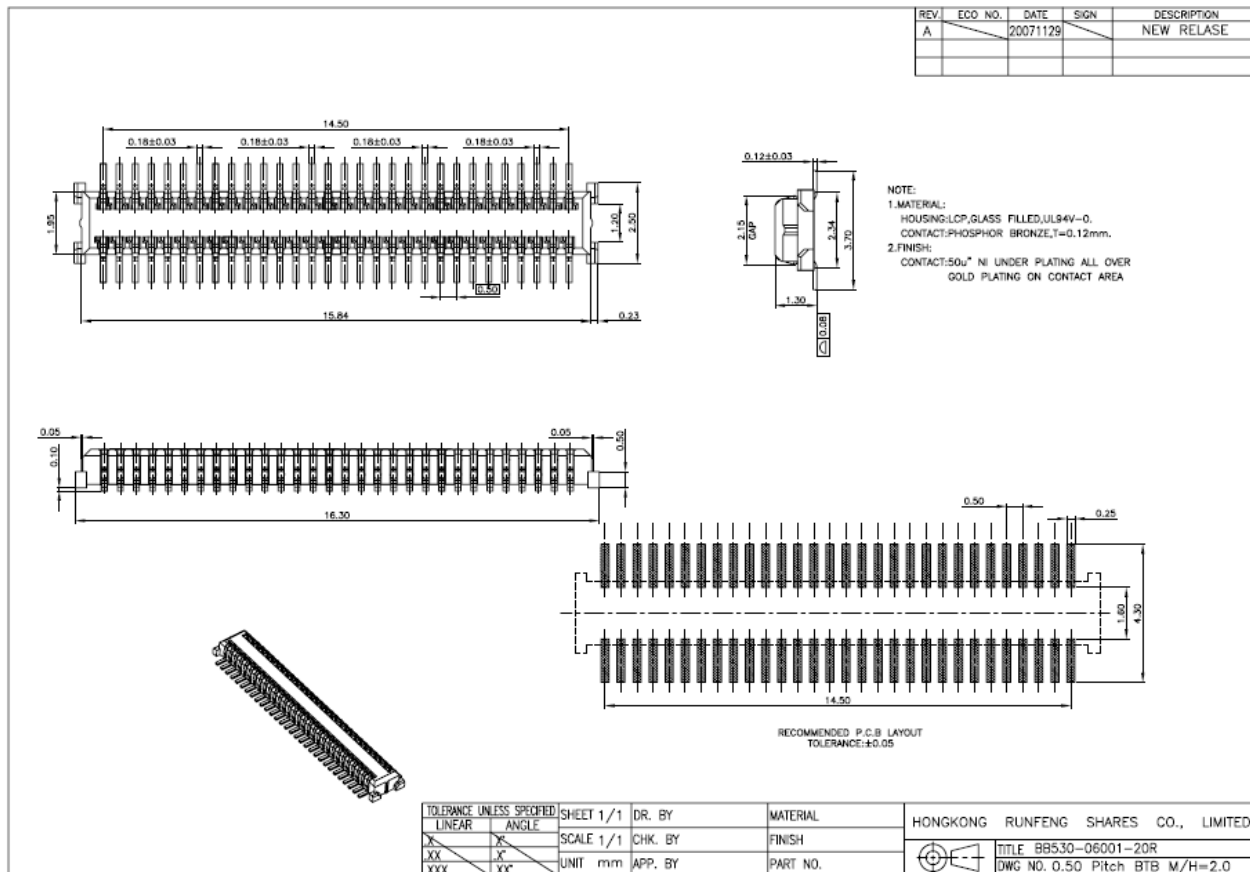

Figure 38: BB530-06001-20R board-to-board connector

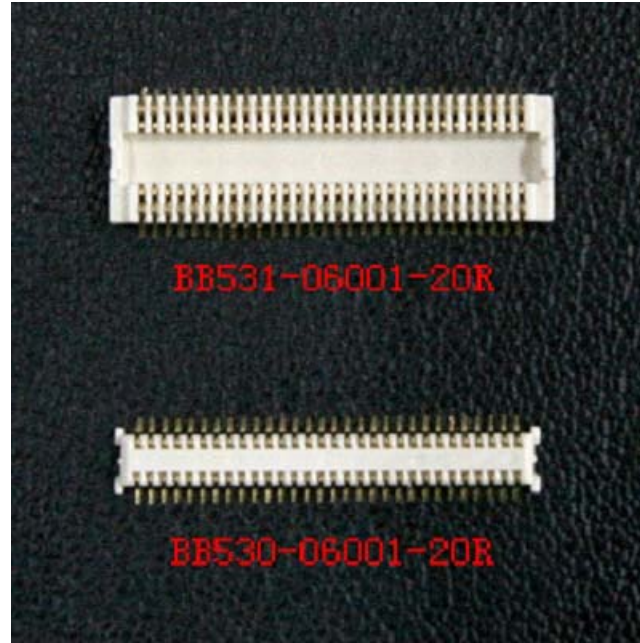

Figure 39 :Board-to-board connector physical photo

6.5 RF connector

The RF connector in module side is a ultra small surface mount coaxial connectors (Part Number: U.FL-R-SMT, vended by HRS). It has high performance with wide frequency range, surface mountable and reflows solderable. Following is parameter (Figure 36). Certainly the user can visit <http://www.hirose-connectors.com/> for more information.

To get good RF performance in customer's design, SIMCom suggests the customer to use the matching RF adapter cable which is also supplied by HRS (Part Number: U.FL-LP (V) -040), the following figure 41 is the dimensions of U.FL series RF adapter cable. User can connect SIMCom for more information.

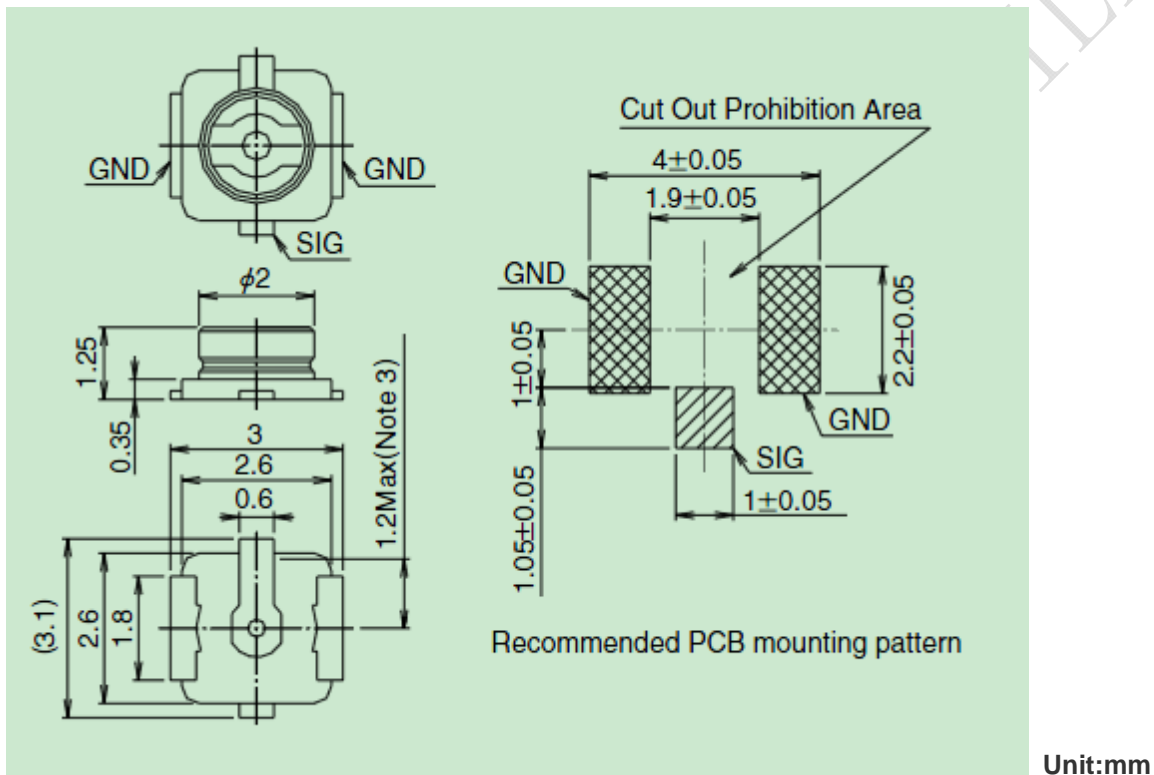

Figure 40: U.FL-R-SMT

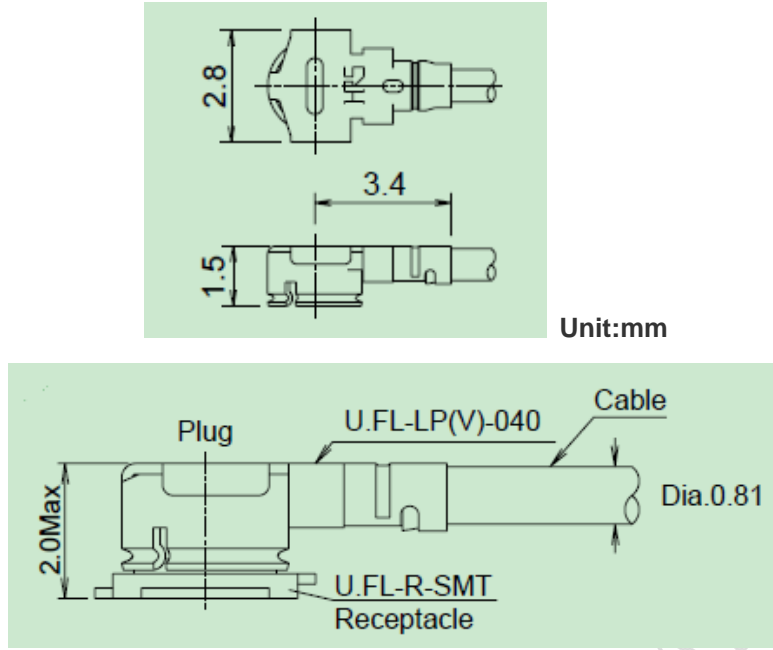

Figure 41: U.FL series RF adapter cable

6.6 PIN Assignment of SIM900B

Table 31: PIN assignment

PIN NO.	PIN NAME	I/O	PIN NO.	PIN NAME	I/O
1	VBAT	I	2	VBAT	I
3	VBAT	I	4	VBAT	I
5	VBAT	I	6	VBAT	I
7	VBAT	I	8	VBAT	I
9	GND		10	GND	
11	GND		12	GND	
13	GND		14	GND	
15	VRTC	I/O	16	SIM_PRESENCE	I
17	VDD_EXT	O	18	DISP_DATA	I/O
19	SIM_VDD	O	20	DISP_CLK	O
21	SIM_DATA	I/O	22	DISP_CS	O
23	SIM_CLK	O	24	DISP_D/C	O
25	SIM_RST	O	26	DISP_RST	O
27	GPIO5/KBC0	I/O	28	DCD	O
29	GPIO4/KBC1	I/O	30	NETLIGHT	O
31	GPIO3/KBC2	I/O	32	GPIO0	I/O
33	GPIO2/KBC3	I/O	34	PWRKEY	I
35	GPIO1/KBC4	I/O	36	BUZZER	O
37	GPIO10/KBR0	I/O	38	DTR	I
39	GPIO9/KBR1	I/O	40	RXD	I
41	GPIO8/KBR2	I/O	42	TXD	O
43	GPIO7/KBR3	I/O	44	RTS	I
45	GPIO6/KBR4	I/O	46	CTS	O
47	DBG_RXD	I	48	RI	O
49	DBG_TXD	O	50	AGND	
51	AGND		52	ADC0	I
53	MIC1P	I	54	SPK1P	O
55	MIC1N	I	56	SPK1N	O
57	MIC2P	I	58	SPK2P	O
59	MIC2N	I	60	SPK2N	O

Contact us:

Shanghai SIMCom Wireless Solutions Ltd.

Add: SIM Technology Building, No.633, Jinzhong Road, Changning District, Shanghai P.R. China
200335

Tel: +86 21 3235 3300

Fax: +86 21 3235 3301

URL: www.sim.com/wm

SIMCOM CONFIDENTIAL FILE