

18V Input, 100mA Current Limited, Micropower Linear Regulator

UM1430S-xx SOT23-3
UM1430S5-xx/UM1440S-xx SOT23-5
UM1430Y-xx/UM1430B-xx SOT89-3
UM1440Y-xx SOT89-5

General Description

The UM1430/1440 series are high input voltage low quiescent current regulators implemented in CMOS technology. It can accept input voltage as high as 18V with 100mA output current limit. The output voltages are selectable in 100mV step within a range of 2.0V to 6.0V. 100mA output current limiting is built in to provide protection for the regulators against fault conditions. CMOS technology ensures low voltage drop and low quiescent current.

With a chip enable control pin, the UM1440 can turn off the output and greatly reduce the power consumption by setting the enable pin low.

The UM1430 is available in SOT23-3, SOT23-5 and SOT89-3 packages. The UM1440 is available in SOT23-5 and SOT89-5 packages.

Applications

- Communication Equipment
- Audio/Video Equipment

Features

- Input Voltage Range: 3.6V to 18V
- 30mA Guaranteed Output Current
- $\pm 3\%$ Voltage Accuracy at 30mA
- Low Dropout Voltage:
250mV (Typical) at 30mA
- Low Quiescent Current:
4.8 μ A @ $V_{IN}=18V$ (Typical)
- Available Fixed Output Voltage from 2.0V to 6.0V with 0.1V Step
- With Enable Control (UM1440S-xx, UM1440Y-xx)
- Output Current Limit
- UM1430: Low Profile SOT23-3, SOT23-5 and SOT89-3 Packages
UM1440: Low Profile SOT23-5 and SOT89-5 Packages

Typical Application Circuit

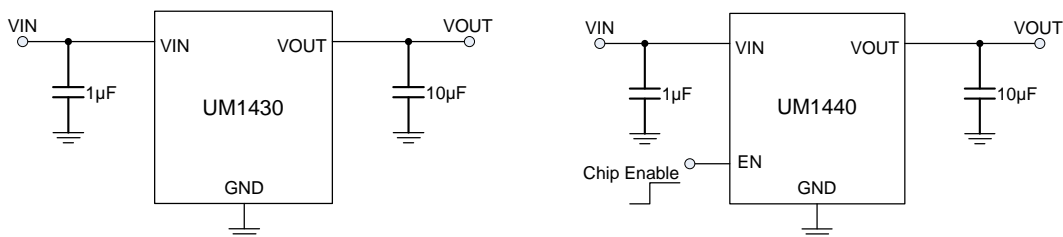

Pin Configurations

Top View

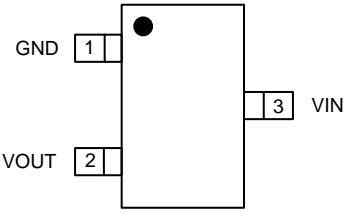
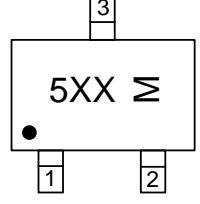
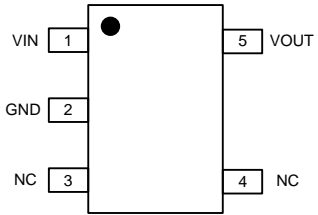
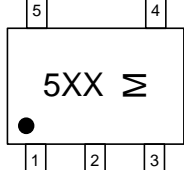
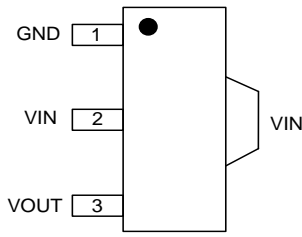
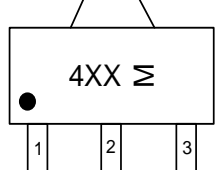
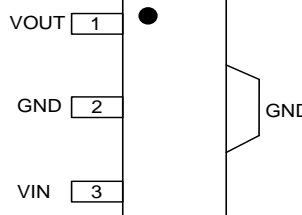
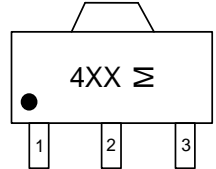
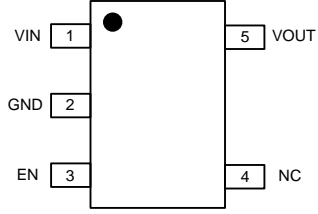
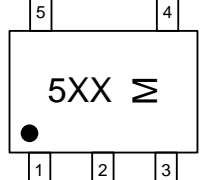
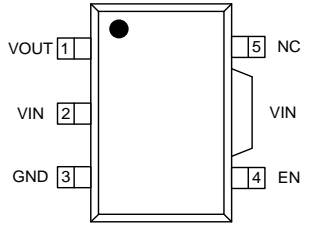
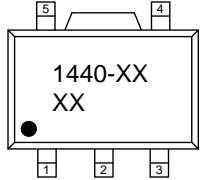
	 <p>M: Month Code UM1430S-xx SOT23-3</p>
	 <p>M: Month Code UM1430S5-xx SOT23-5</p>
	 <p>M: Month Code UM1430Y-xx SOT89-3</p>
	 <p>M: Month Code UM1430B-xx SOT89-3</p>
	 <p>M: Month Code UM1440S-xx SOT23-5</p>
	 <p>XX: Week Code UM1440Y-xx SOT89-5</p>

Pin Description

Pin Name	Pin Function
EN	Enable Input: High=Activate LDO, Low=Shutdown LDO
GND	Ground
VIN	Supply Input
VOUT	Voltage Regulated Output
NC	Not Connected

Naming Information

UM1430/1440 □ □ - □ □

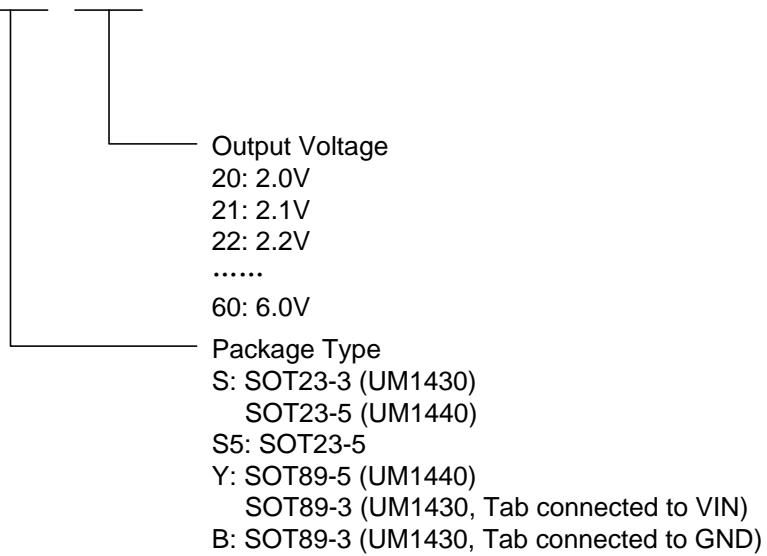

Ordering Information

Part Number	Output Voltage	Packaging Type	Marking Code	Shipping Qty
UM1430S-20	2.0V	SOT23-3	5QA	3000pcs/7Inch Tape & Reel
UM1430S-21	2.1V		5QB	
UM1430S-22	2.2V		5Q2	
UM1430S-23	2.3V		5Q3	
UM1430S-24	2.4V		5Q4	
UM1430S-25	2.5V		5Q5	
UM1430S-26	2.6V		5Q6	
UM1430S-27	2.7V		5Q7	
UM1430S-28	2.8V		5Q8	
UM1430S-29	2.9V		5Q9	
UM1430S-30	3.0V		5QC	
UM1430S-31	3.1V		5QD	
UM1430S-32	3.2V		5QE	
UM1430S-33	3.3V		5QF	
UM1430S-34	3.4V		5QH	
UM1430S-35	3.5V		5QL	
UM1430S-36	3.6V		5QM	
UM1430S-37	3.7V		5QJ	
UM1430S-38	3.8V		5QK	
UM1430S-39	3.9V		5QN	
UM1430S-40	4.0V		5QP	
UM1430S-41	4.1V		5QQ	
UM1430S-42	4.2V		5QR	
UM1430S-43	4.3V		5QS	
UM1430S-44	4.4V		5QT	
UM1430S-45	4.5V		5QY	
UM1430S-46	4.6V		5QU	
UM1430S-47	4.7V		5QZ	
UM1430S-48	4.8V		5RA	
UM1430S-49	4.9V		5RB	
UM1430S-50	5.0V		5RC	
UM1430S-51	5.1V		5RD	
UM1430S-52	5.2V		5R2	
UM1430S-53	5.3V		5R3	
UM1430S-54	5.4V		5R4	
UM1430S-55	5.5V		5R5	
UM1430S-56	5.6V		5R6	
UM1430S-57	5.7V		5R7	
UM1430S-58	5.8V		5R8	
UM1430S-59	5.9V		5R9	
UM1430S-60	6.0V		5RE	

Ordering Information (Continued)

Part Number	Output Voltage	Packaging Type	Marking Code	Shipping Qty
UM1430S5-20	2.0V	SOT23-5	5HF	3000pcs/7Inch Tape & Reel
UM1430S5-21	2.1V		5HL	
UM1430S5-22	2.2V		5HM	
UM1430S5-23	2.3V		5H3	
UM1430S5-24	2.4V		5H4	
UM1430S5-25	2.5V		5H5	
UM1430S5-26	2.6V		5H6	
UM1430S5-27	2.7V		5H7	
UM1430S5-28	2.8V		5H8	
UM1430S5-29	2.9V		5HK	
UM1430S5-30	3.0V		5HZ	
UM1430S5-31	3.1V		5FZ	
UM1430S5-32	3.2V		5KR	
UM1430S5-33	3.3V		5KS	
UM1430S5-34	3.4V		5KT	
UM1430S5-35	3.5V		5KY	
UM1430S5-36	3.6V		5KU	
UM1430S5-37	3.7V		5KZ	
UM1430S5-38	3.8V		5JC	
UM1430S5-39	3.9V		5JD	
UM1430S5-40	4.0V		5JE	
UM1430S5-41	4.1V		5JF	
UM1430S5-42	4.2V		5JH	
UM1430S5-43	4.3V		5JL	
UM1430S5-44	4.4V		5JM	
UM1430S5-45	4.5V		5JJ	
UM1430S5-46	4.6V		5JK	
UM1430S5-47	4.7V		5JW	
UM1430S5-48	4.8V		5JP	
UM1430S5-49	4.9V		5JQ	
UM1430S5-50	5.0V		5JR	
UM1430S5-51	5.1V		5JS	
UM1430S5-52	5.2V		5JT	
UM1430S5-53	5.3V		5JY	
UM1430S5-54	5.4V		5JU	
UM1430S5-55	5.5V		5JZ	
UM1430S5-56	5.6V		5NC	
UM1430S5-57	5.7V		5ND	
UM1430S5-58	5.8V		5NE	
UM1430S5-59	5.9V		5NF	
UM1430S5-60	6.0V		5NH	

Ordering Information (Continued)

Part Number	Output Voltage	Packaging Type	Marking Code	Shipping Qty
UM1430Y-20	2.0V	SOT89-3 (Tab connected to VIN)	4EA	1000pcs/7Inch Tape & Reel
UM1430Y-21	2.1V		4EB	
UM1430Y-22	2.2V		4E2	
UM1430Y-23	2.3V		4E3	
UM1430Y-24	2.4V		4E4	
UM1430Y-25	2.5V		4E5	
UM1430Y-26	2.6V		4E6	
UM1430Y-27	2.7V		4E7	
UM1430Y-28	2.8V		4E8	
UM1430Y-29	2.9V		4E9	
UM1430Y-30	3.0V		4EC	
UM1430Y-31	3.1V		4ED	
UM1430Y-32	3.2V		4EE	
UM1430Y-33	3.3V		4EF	
UM1430Y-34	3.4V		4EH	
UM1430Y-35	3.5V		4EL	
UM1430Y-36	3.6V		4EM	
UM1430Y-37	3.7V		4EJ	
UM1430Y-38	3.8V		4EK	
UM1430Y-39	3.9V		4EN	
UM1430Y-40	4.0V		4EP	
UM1430Y-41	4.1V		4EQ	
UM1430Y-42	4.2V		4ER	
UM1430Y-43	4.3V		4ES	
UM1430Y-44	4.4V		4ET	
UM1430Y-45	4.5V		4EY	
UM1430Y-46	4.6V		4EU	
UM1430Y-47	4.7V		4EZ	
UM1430Y-48	4.8V		4FA	
UM1430Y-49	4.9V		4FB	
UM1430Y-50	5.0V		4FC	
UM1430Y-51	5.1V		4FD	
UM1430Y-52	5.2V		4F2	
UM1430Y-53	5.3V		4F3	
UM1430Y-54	5.4V		4F4	
UM1430Y-55	5.5V		4F5	
UM1430Y-56	5.6V		4F6	
UM1430Y-57	5.7V		4F7	
UM1430Y-58	5.8V		4F8	
UM1430Y-59	5.9V		4F9	
UM1430Y-60	6.0V		4FE	

Ordering Information (Continued)

Part Number	Output Voltage	Packaging Type	Marking Code	Shipping Qty
UM1430B-20	2.0V	SOT89-3 (Tab connected to GND)	4HA	1000pcs/7Inch Tape & Reel
UM1430B-21	2.1V		4HB	
UM1430B-22	2.2V		4H2	
UM1430B-23	2.3V		4H3	
UM1430B-24	2.4V		4H4	
UM1430B-25	2.5V		4H5	
UM1430B-26	2.6V		4H6	
UM1430B-27	2.7V		4H7	
UM1430B-28	2.8V		4H8	
UM1430B-29	2.9V		4H9	
UM1430B-30	3.0V		4HC	
UM1430B-31	3.1V		4HD	
UM1430B-32	3.2V		4HE	
UM1430B-33	3.3V		4HF	
UM1430B-34	3.4V		4HH	
UM1430B-35	3.5V		4HL	
UM1430B-36	3.6V		4HM	
UM1430B-37	3.7V		4HJ	
UM1430B-38	3.8V		4HK	
UM1430B-39	3.9V		4HN	
UM1430B-40	4.0V		4HP	
UM1430B-41	4.1V		4HQ	
UM1430B-42	4.2V		4HR	
UM1430B-43	4.3V		4HS	
UM1430B-44	4.4V		4HT	
UM1430B-45	4.5V		4HY	
UM1430B-46	4.6V		4HU	
UM1430B-47	4.7V		4HZ	
UM1430B-48	4.8V		4JA	
UM1430B-49	4.9V		4JB	
UM1430B-50	5.0V		4JC	
UM1430B-51	5.1V		4JD	
UM1430B-52	5.2V		4J2	
UM1430B-53	5.3V		4J3	
UM1430B-54	5.4V		4J4	
UM1430B-55	5.5V		4J5	
UM1430B-56	5.6V		4J6	
UM1430B-57	5.7V		4J7	
UM1430B-58	5.8V		4J8	
UM1430B-59	5.9V		4J9	
UM1430B-60	6.0V		4JE	

Ordering Information (Continued)

Part Number	Output Voltage	Packaging Type	Marking Code	Shipping Qty
UM1440S-20	2.0V	SOT23-5	5SA	3000pcs/7Inch Tape & Reel
UM1440S-21	2.1V		5SB	
UM1440S-22	2.2V		5S2	
UM1440S-23	2.3V		5S3	
UM1440S-24	2.4V		5S4	
UM1440S-25	2.5V		5S5	
UM1440S-26	2.6V		5S6	
UM1440S-27	2.7V		5S7	
UM1440S-28	2.8V		5S8	
UM1440S-29	2.9V		5S9	
UM1440S-30	3.0V		5SC	
UM1440S-31	3.1V		5SD	
UM1440S-32	3.2V		5SE	
UM1440S-33	3.3V		5SF	
UM1440S-34	3.4V		5SH	
UM1440S-35	3.5V		5SL	
UM1440S-36	3.6V		5SM	
UM1440S-37	3.7V		5SJ	
UM1440S-38	3.8V		5SK	
UM1440S-39	3.9V		5SN	
UM1440S-40	4.0V		5SP	
UM1440S-41	4.1V		5SQ	
UM1440S-42	4.2V		5SR	
UM1440S-43	4.3V		5SS	
UM1440S-44	4.4V		5ST	
UM1440S-45	4.5V		5SY	
UM1440S-46	4.6V		5SU	
UM1440S-47	4.7V		5SZ	
UM1440S-48	4.8V		5TA	
UM1440S-49	4.9V		5TB	
UM1440S-50	5.0V		5TC	
UM1440S-51	5.1V		5TD	
UM1440S-52	5.2V		5T2	
UM1440S-53	5.3V		5T3	
UM1440S-54	5.4V		5T4	
UM1440S-55	5.5V		5T5	
UM1440S-56	5.6V		5T6	
UM1440S-57	5.7V		5T7	
UM1440S-58	5.8V		5T8	
UM1440S-59	5.9V		5T9	
UM1440S-60	6.0V		5TE	

Ordering Information (Continued)

Part Number	Output Voltage	Packaging Type	Marking Code	Shipping Qty
UM1440Y-20	2.0V	SOT89-5	1440-20	1000pcs/7Inch Tape & Reel
UM1440Y-21	2.1V		1440-21	
UM1440Y-22	2.2V		1440-22	
UM1440Y-23	2.3V		1440-23	
UM1440Y-24	2.4V		1440-24	
UM1440Y-25	2.5V		1440-25	
UM1440Y-26	2.6V		1440-26	
UM1440Y-27	2.7V		1440-27	
UM1440Y-28	2.8V		1440-28	
UM1440Y-29	2.9V		1440-29	
UM1440Y-30	3.0V		1440-30	
UM1440Y-31	3.1V		1440-31	
UM1440Y-32	3.2V		1440-32	
UM1440Y-33	3.3V		1440-33	
UM1440Y-34	3.4V		1440-34	
UM1440Y-35	3.5V		1440-35	
UM1440Y-36	3.6V		1440-36	
UM1440Y-37	3.7V		1440-37	
UM1440Y-38	3.8V		1440-38	
UM1440Y-39	3.9V		1440-39	
UM1440Y-40	4.0V		1440-40	
UM1440Y-41	4.1V		1440-41	
UM1440Y-42	4.2V		1440-42	
UM1440Y-43	4.3V		1440-43	
UM1440Y-44	4.4V		1440-44	
UM1440Y-45	4.5V		1440-45	
UM1440Y-46	4.6V		1440-46	
UM1440Y-47	4.7V		1440-47	
UM1440Y-48	4.8V		1440-48	
UM1440Y-49	4.9V		1440-49	
UM1440Y-50	5.0V		1440-50	
UM1440Y-51	5.1V		1440-51	
UM1440Y-52	5.2V		1440-52	
UM1440Y-53	5.3V		1440-53	
UM1440Y-54	5.4V		1440-54	
UM1440Y-55	5.5V		1440-55	
UM1440Y-56	5.6V		1440-56	
UM1440Y-57	5.7V		1440-57	
UM1440Y-58	5.8V		1440-58	
UM1440Y-59	5.9V		1440-59	
UM1440Y-60	6.0V	1440-60		

Absolute Maximum Ratings (Note 1)

Symbol	Parameter		Value	Unit
V _{IN}	Supply Voltage on VIN Pin		-0.3 to +24	V
V _{OUT}	Voltage on VOUT Pin		-0.3 to +24	V
T _J	Operating Junction Temperature (Notes 2, 3)		-40 to +125	°C
T _{STG}	Storage Temperature Range		-65 to +150	°C
T _L	Lead Temperature for Soldering 10 Seconds		+260	°C
P _D (Notes 4)	Power Dissipation@25°C	SOT23-3	0.40	W
		SOT89-3	1.0	
		SOT23-5	0.43	
		SOT89-5	1.20	
θ _{JA}	Package Thermal Resistance	SOT23-3	250	°C/W
		SOT89-3	100	
		SOT23-5	230	
		SOT89-5	83	

Note 1: Absolute Maximum Ratings are those values beyond which the life of a device may be impaired.

Note 2: The UM1430/1440 is tested and specified under pulse load conditions such that $T_J \approx T_A$. Specifications over the -40°C to 125°C operating junction temperature range are assured by design, characterization and correlation with statistical process controls.

Note 3: This IC includes over temperature protection that is intended to protect the device during momentary overload conditions. Junction temperature will exceed 125°C when over temperature protection is active. Continuous operation above the specified maximum operating junction temperature may impair device reliability.

Note 4: The maximum allowable power dissipation of any T_A (ambient temperature) is $P_{DMAX} = (T_{JMAX} - T_A) / \theta_{JA}$. Exceeding the maximum allowable power dissipation will result in excessive die temperature and the regulator will go into thermal shutdown.

Electrical Characteristics
 $V_{IN} = V_{OUT} + 1V$, $C_{IN} = 1\mu F$, $C_{OUT} = 10\mu F$, $T_A = 25^\circ C$.

Symbol	Parameter	Test Conditions	Min	Typ	Max	Unit
V_{IN}	Input Voltage Range		3.6		18	V
V_{OUT}	Output Voltage Range		2.0		6.0	V
I_Q	Operating Quiescent Current	$I_{OUT} = 0mA$, $V_{IN} = 18V$		4.8	7.0	μA
		$V_{IN} = 18V$, $I_{OUT} = 30mA$		70		
I_{SHDN}	Shutdown Leakage Current			1.3	2	μA
I_{OUT}	Output Current		30			mA
	Output Voltage Accuracy	$I_{OUT} = 30mA$, $T_A = +25^\circ C$	-3		+3	%
ΔV_{DO}	Dropout Voltage	$I_{OUT} = 30mA$		250	350	mV
I_{LIMIT}	Output Current Limit	$V_{IN} \geq 2.5V$		100		mA
t	Startup Time Response			150		μs
V_{IL}	Enable Input Low Voltage				0.7	V
V_{IH}	Enable Input High Voltage		2.0			V
T_C	Output Voltage Temperature Coefficient	$I_{OUT} = 10mA$		150		ppm/ $^\circ C$
	Line Regulation	$V_{OUT} + 1V \leq V_{IN} \leq 18V$ ($3.6V \leq V_{IN}$) $I_{OUT} = 10mA$		0.05		%/V
	Load Regulation	$V_{IN} = V_{OUT} + 1V$ ($3.6V \leq V_{IN}$) $1\mu A \leq I_{OUT} \leq 30mA$		15		mV
	Output Voltage Noise	10Hz to 100kHz $C_{IN} = 1\mu F$, $I_{OUT} = 100mA$ $V_{OUT} = 2.0V$		450		μV_{RMS}
PSRR	Power Supply Ripple Rejection	$V_{IN} = V_{OUT} + 1V$ $I_{OUT} = 100mA$ ($3.6V \leq V_{IN}$)	f=100Hz		55	dB
			f=1kHz		45	
			f=10kHz		35	

Typical Performance Characteristics

Quiescent Current vs. Input Voltage
 $I_{OUT}=0mA$

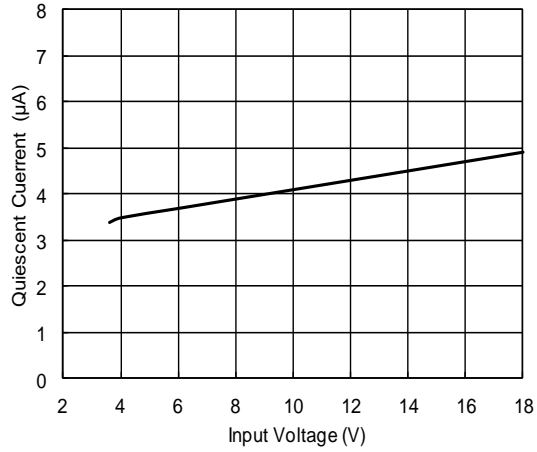

Quiescent Current vs. Temperature
 $V_{IN}=18V, I_{OUT}=0mA$

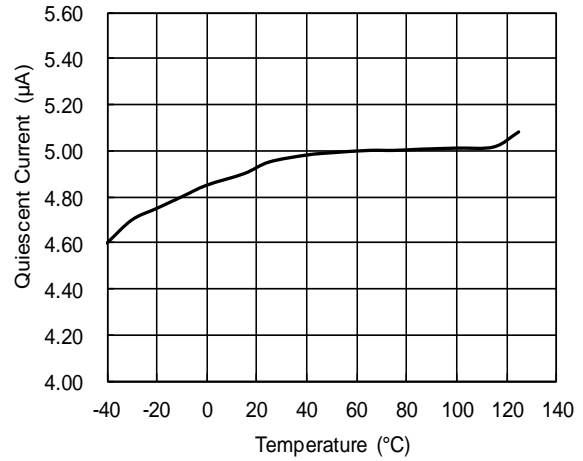

Ground Current vs. Output Current
 $V_{IN}=18V$

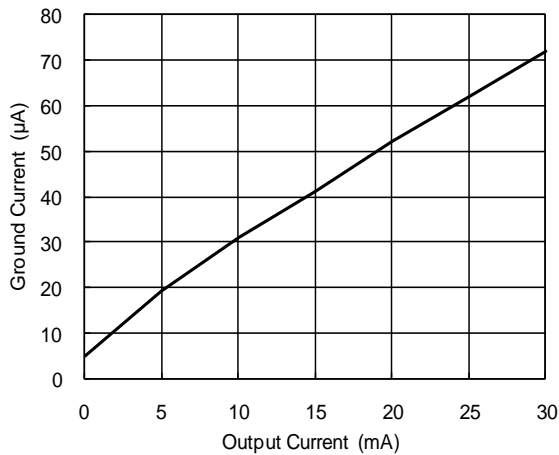

Enable Threshold Voltage vs. Input Voltage

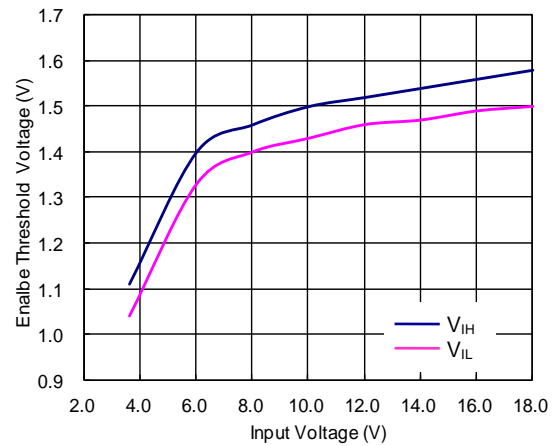

Output Voltage vs. Input Voltage
UM1440S-20

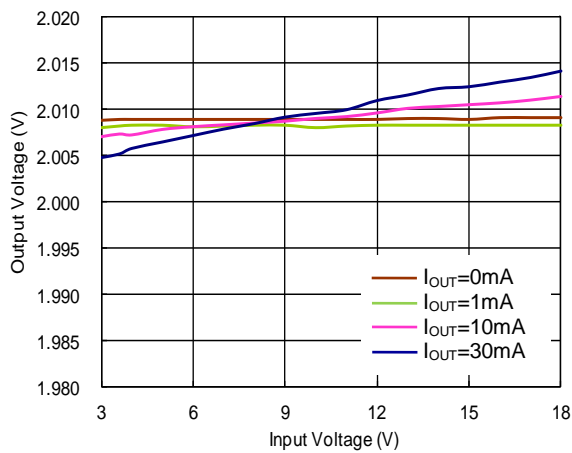

Output Voltage vs. Output Current
UM1440S-20, $V_{IN}=4.0V$

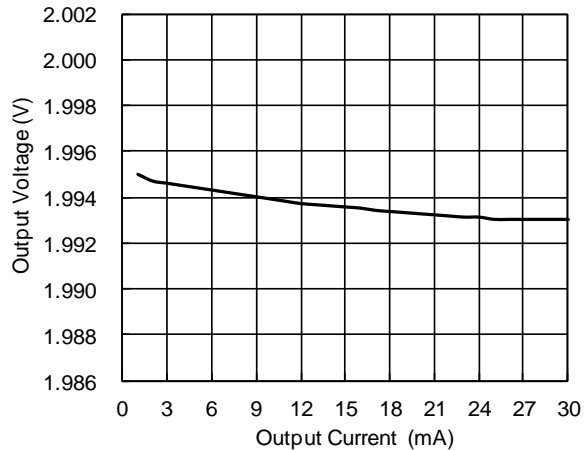

Typical Performance Characteristics (Continued)

Output Voltage vs. Temperature
 $V_{IN}=3.6V, I_{OUT}=1mA$

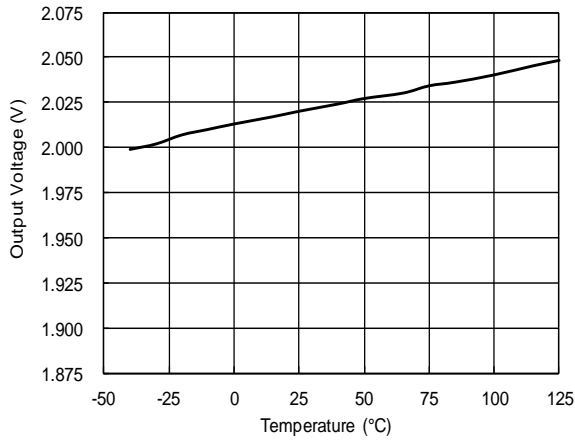

Output Voltage vs. Temperature
 $V_{IN}=18V, I_{OUT}=1mA$

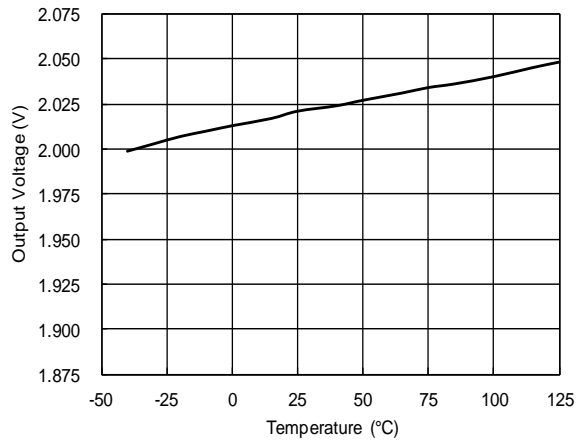

Shutdown Leakage Current vs. Input Voltage

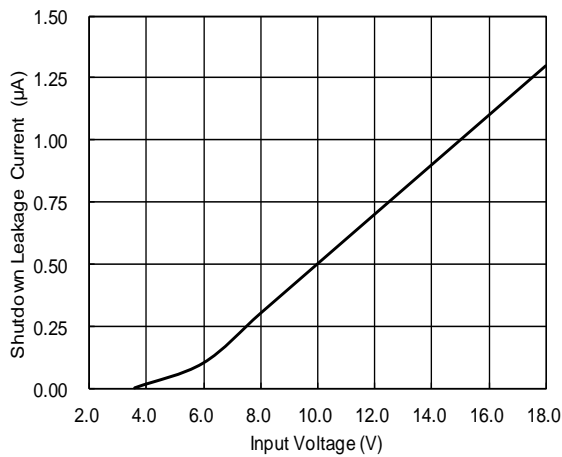

Shutdown Leakage Current vs. Temperature
 $V_{IN}=18V$

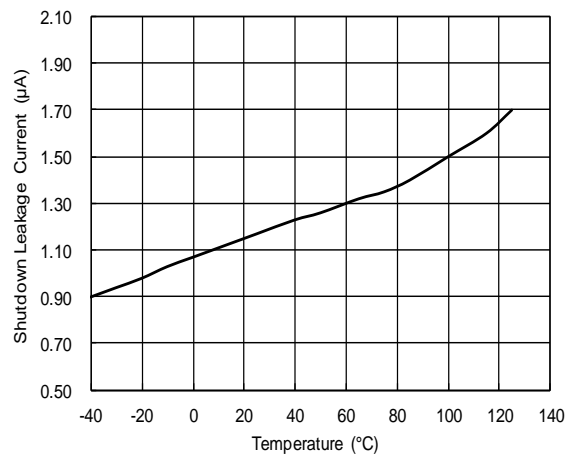

PSRR vs. Frequency

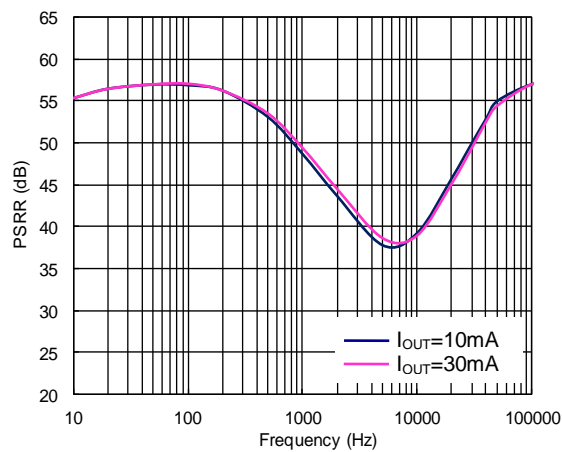

Dropout Voltage vs. Output Current
 UM1430S5-40

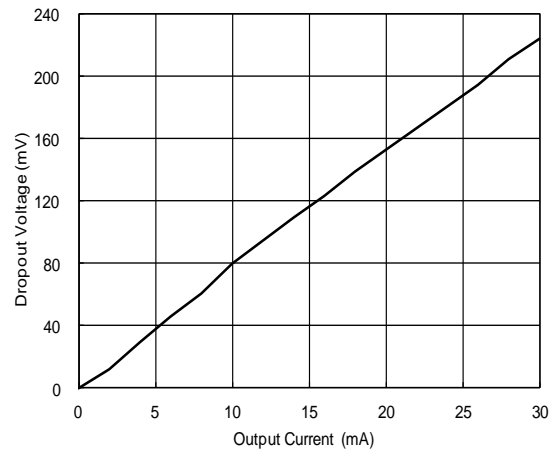

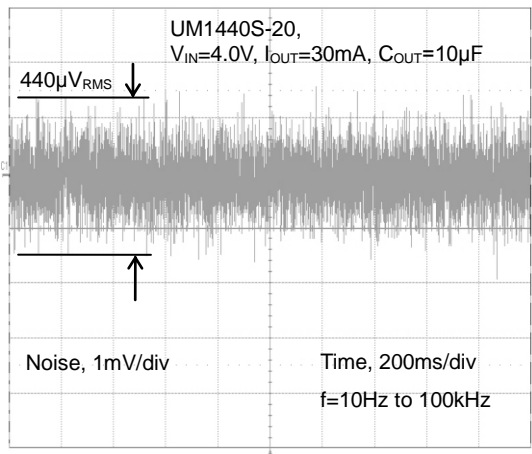
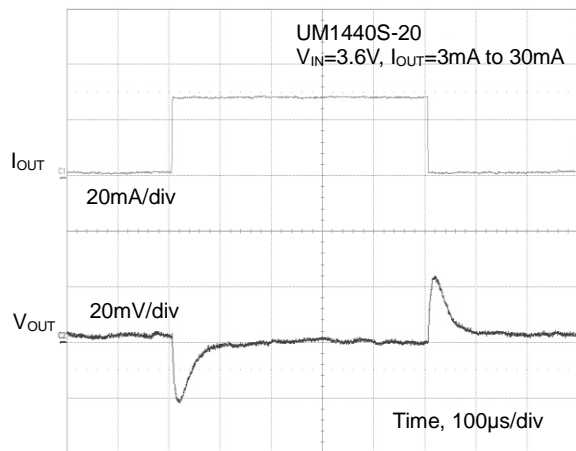
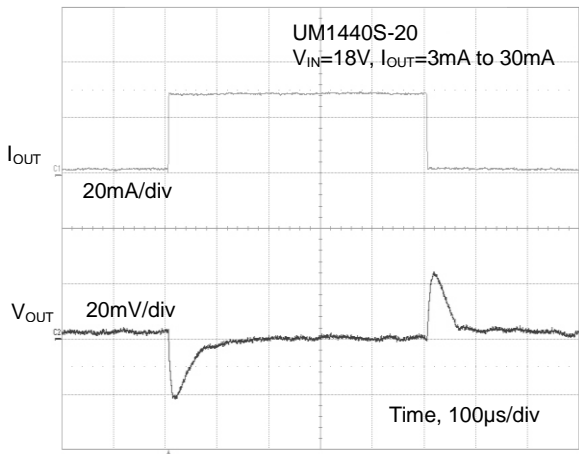
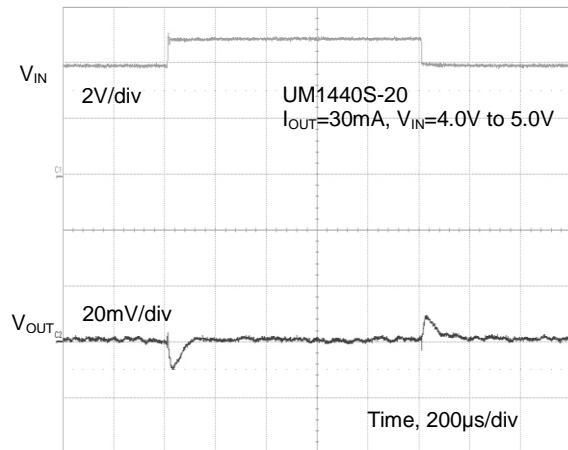
Typical Performance Characteristics (Continued)
Noise

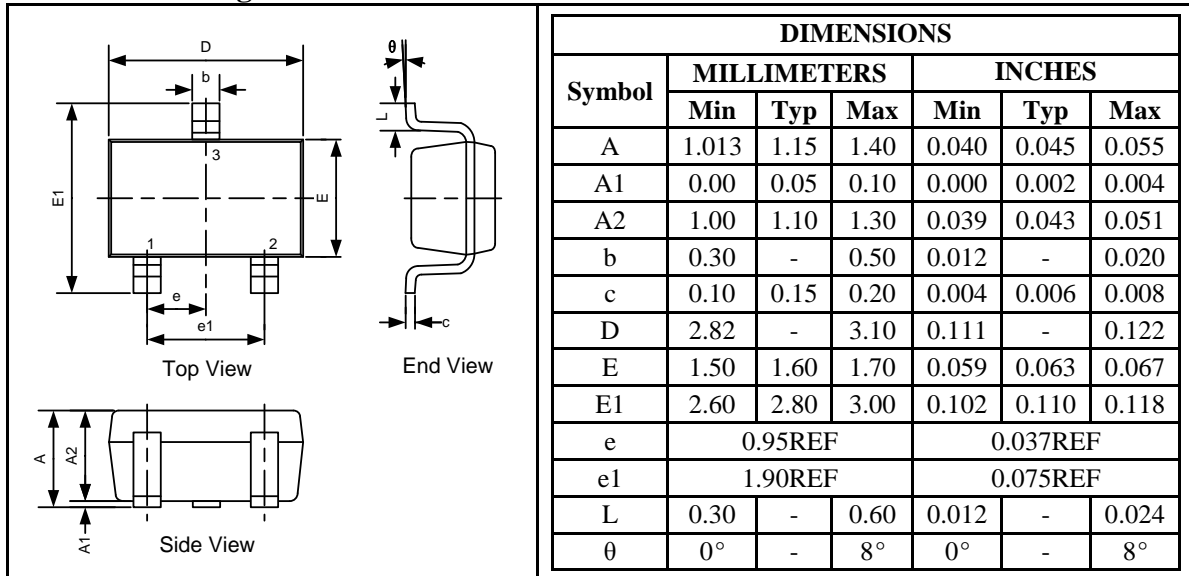
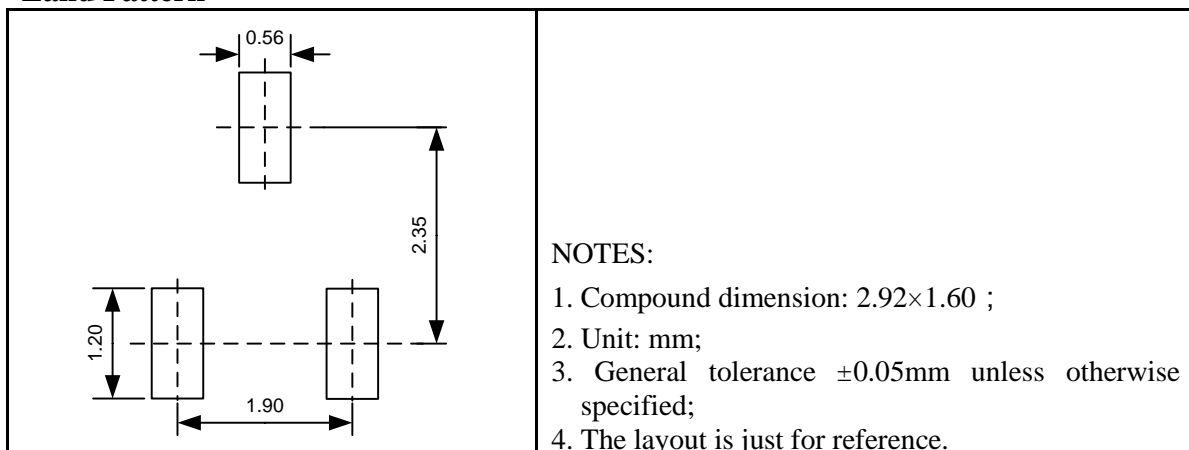
Load Transient Response

Load Transient Response

Line Transient Response

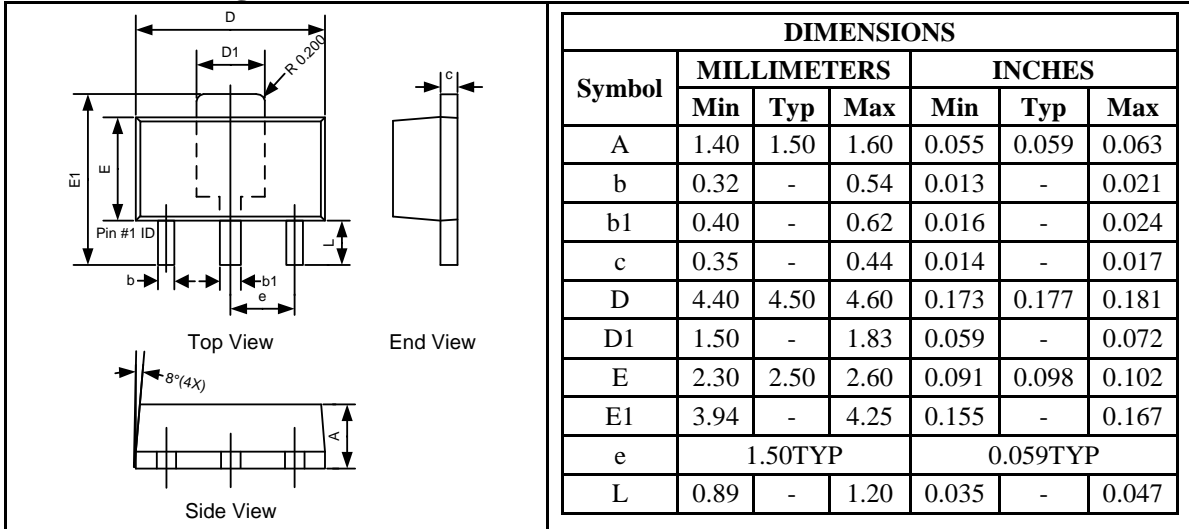
Package Information
UM1430S-xx: SOT23-3
Outline Drawing

Land Pattern

Tape and Reel Orientation

UM1430Y-xx, UM1430B-xx: SOT89-3

Outline Drawing

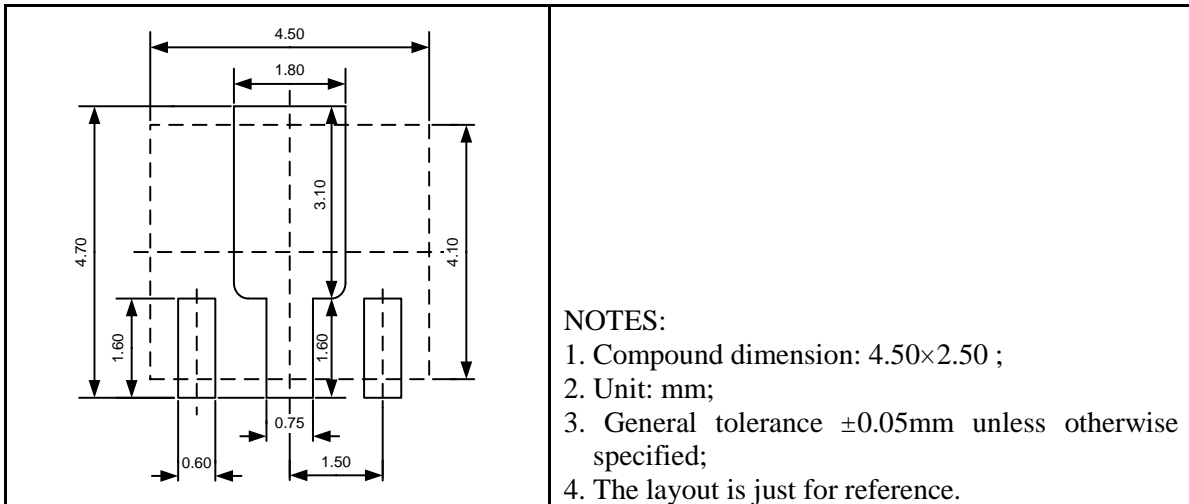

Land Pattern



Tape and Reel Orientation

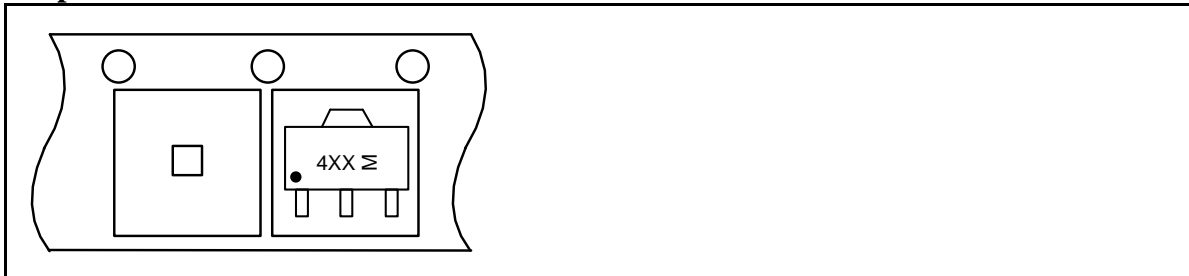

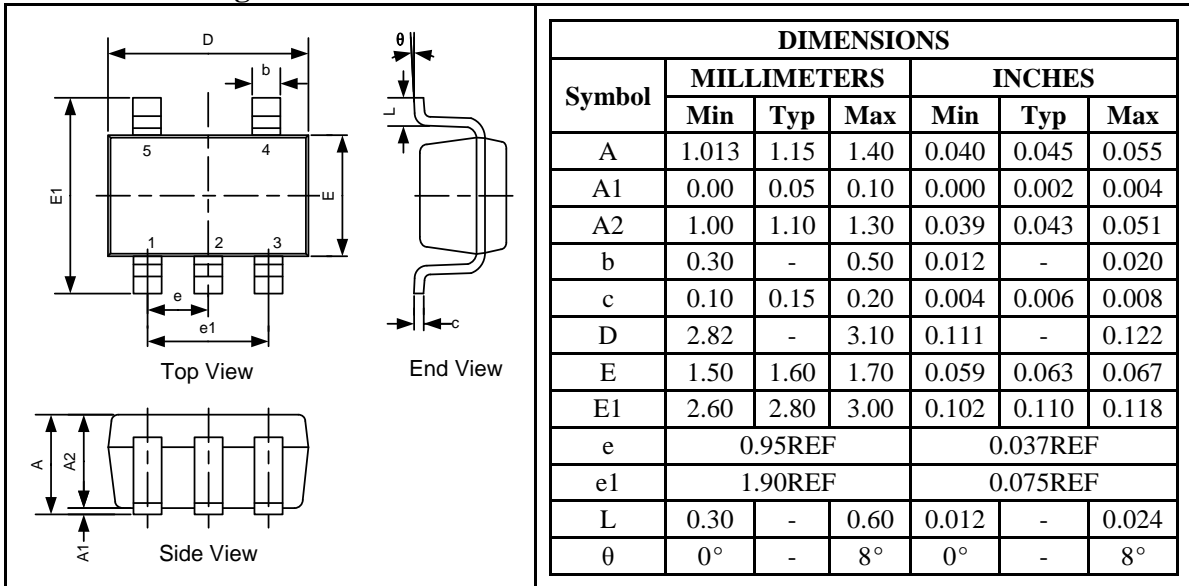
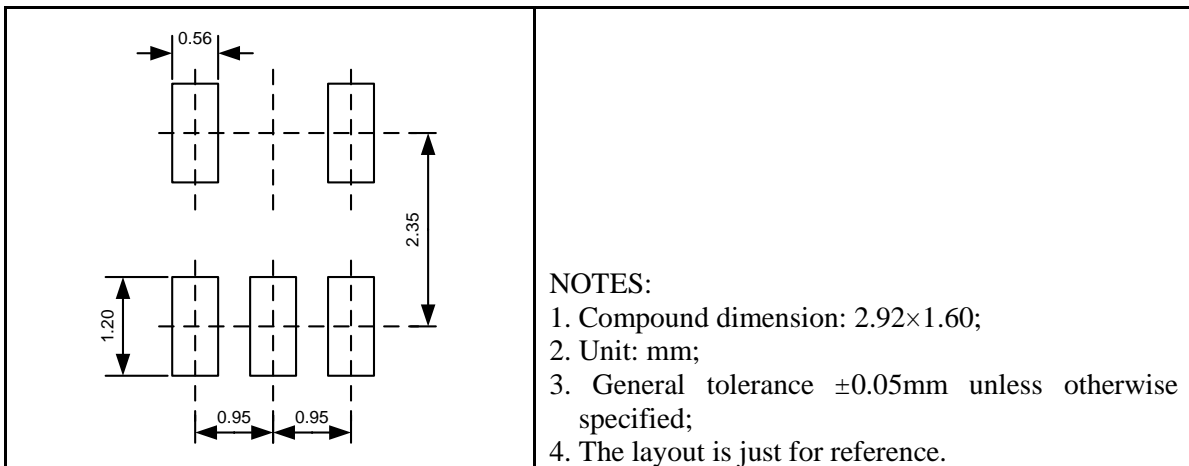
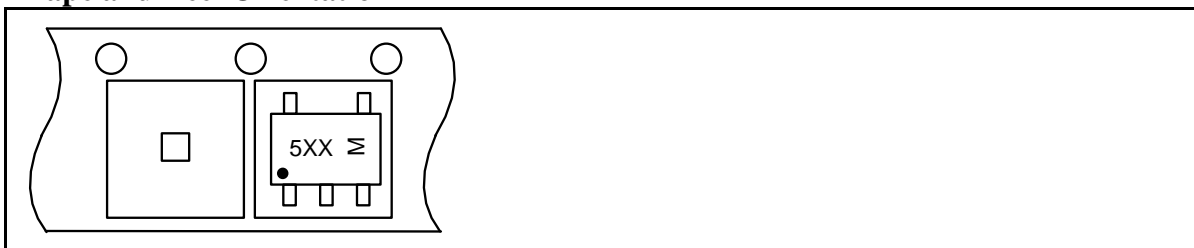
UM1430S5-xx, UM1440S-xx: SOT23-5
Outline Drawing

Land Pattern

Tape and Reel Orientation

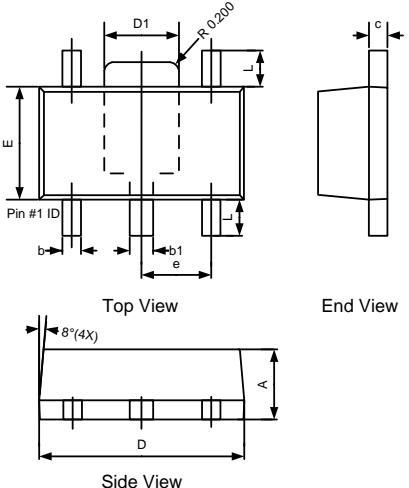
UM1440Y-xx: SOT89-5

Outline Drawing



DIMENSIONS						
Symbol	MILLIMETERS			INCHES		
	Min	Typ	Max	Min	Typ	Max
A	1.40	1.50	1.60	0.055	0.059	0.063
b	0.32	-	0.54	0.013	-	0.021
b1	0.38	-	0.62	0.015	-	0.024
c	0.35	-	0.44	0.014	-	0.017
D	4.40	4.50	4.60	0.173	0.177	0.181
D1	1.40	-	1.83	0.055	-	0.072
E	2.30	2.50	2.60	0.091	0.098	0.102
e	1.50TYP			0.059TYP		
L	0.65	-	1.20	0.026	-	0.047

Land Pattern

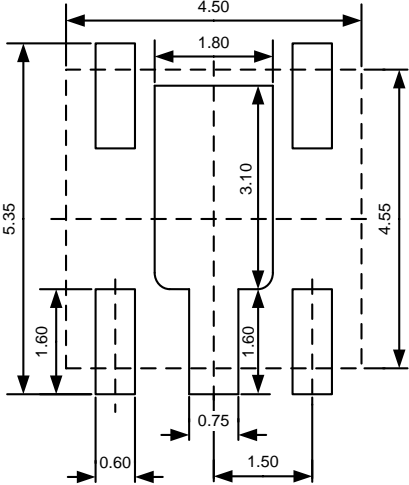

NOTES:

1. Compound dimension: 4.50×2.50;
2. Unit: mm;
3. General tolerance ±0.05mm unless otherwise specified;
4. The layout is just for reference.

Tape and Reel Orientation



GREEN COMPLIANCE

Union Semiconductor is committed to environmental excellence in all aspects of its operations including meeting or exceeding regulatory requirements with respect to the use of hazardous substances. Numerous successful programs have been implemented to reduce the use of hazardous substances and/or emissions.

All Union components are compliant with the RoHS directive, which helps to support customers in their compliance with environmental directives. For more green compliance information, please visit:

http://www.union-ic.com/index.aspx?cat_code=RoHSDeclaration

IMPORTANT NOTICE

The information in this document has been carefully reviewed and is believed to be accurate. Nonetheless, this document is subject to change without notice. Union assumes no responsibility for any inaccuracies that may be contained in this document, and makes no commitment to update or to keep current the contained information, or to notify a person or organization of any update. Union reserves the right to make changes, at any time, in order to improve reliability, function or design and to attempt to supply the best product possible.



Union Semiconductor, Inc

Add: Unit 606, No.570 Shengxia Road, Shanghai 201210

Tel: 021-51093966

Fax: 021-51026018

Website: www.union-ic.com