

# LM117HV/LM317HV

## 3-Terminal Adjustable Regulator

### General Description

The LM117HV/LM317HV are adjustable 3-terminal positive voltage regulators capable of supplying in excess of 1.5A over a 1.2V to 57V output range. They are exceptionally easy to use and require only two external resistors to set the output voltage. Further, both line and load regulation are better than standard fixed regulators. Also, the LM117HV is packaged in standard transistor packages which are easily mounted and handled.

In addition to higher performance than fixed regulators, the LM117HV series offers full overload protection available only in IC's. Included on the chip are current limit, thermal overload protection and safe area protection. All overload protection circuitry remains fully functional even if the adjustment terminal is disconnected.

Normally, no capacitors are needed unless the device is situated more than 6 inches from the input filter capacitors in which case an input bypass is needed. An optional output capacitor can be added to improve transient response. The adjustment terminal can be bypassed to achieve very high ripple rejections ratios which are difficult to achieve with standard 3-terminal regulators.

Besides replacing fixed regulators, the LM117HV is useful in a wide variety of other applications. Since the regulator is "floating" and sees only the input-to-output differential voltage, supplies of several hundred volts can be regulated as long as the maximum input to output differential is not exceeded, i.e. do not short the output to ground.

Also, it makes an especially simple adjustable switching regulator, a programmable output regulator, or by connecting a fixed resistor between the adjustment and output, the LM117HV can be used as a precision current regulator. Supplies with electronic shutdown can be achieved by clamping the adjustment terminal to ground which programs the output to 1.2V where most loads draw little current.

The LM117HVK STEEL and LM317HVK STEEL are packaged in standard TO-3 transistor packages, while the LM117HVH and LM317HVH are packaged in a solid Kovar base TO-39 transistor package. The LM317HVT uses a TO-220 plastic package. The LM117HV is rated for operation from  $-55^{\circ}\text{C}$  to  $+150^{\circ}\text{C}$ , and the LM317HV from  $0^{\circ}\text{C}$  to  $+125^{\circ}\text{C}$ .

### Features

- Adjustable output down to 1.2V
- Guaranteed 1.5A output current
- Line regulation typically 0.01%/V
- Load regulation typically 0.1%
- Current limit constant with temperature
- 100% electrical burn-in
- Eliminates the need to stock many voltages
- Standard 3-lead transistor package
- 80 dB ripple rejection
- Output is short-circuit protected
- P<sup>+</sup> Product Enhancement tested

### Typical Applications

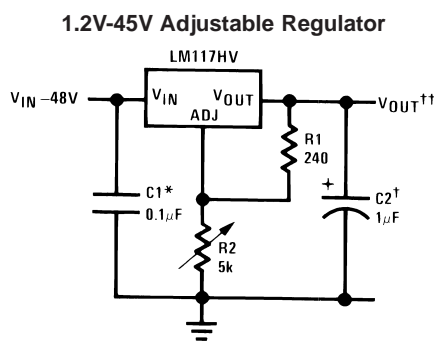

Full output current not available at high input-output voltages

†Optional—improves transient response. Output capacitors in the range of 1  $\mu\text{F}$  to 1000  $\mu\text{F}$  of aluminum or tantalum electrolytic are commonly used to provide improved output impedance and rejection of transients.

\*Needed if device is more than 6 inches from filter capacitors.

$$\dagger\dagger V_{\text{OUT}} = 1.25\text{V} \left( 1 + \frac{R_2}{R_1} \right) + I_{\text{ADJ}} R_2$$

## Typical Applications (Continued)

### Digitally Selected Outputs

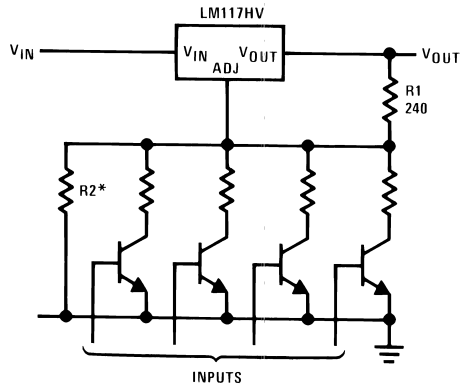

DS009062-2

\*Sets maximum  $V_{OUT}$

### 5V Logic Regulator with Electronic Shutdown\*

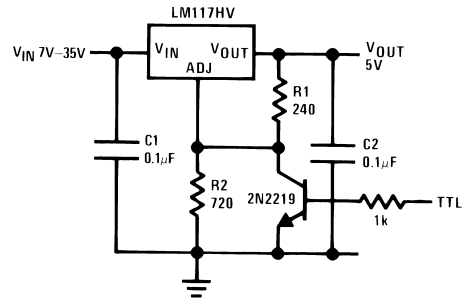

DS009062-3

\*Min. output  $\approx 1.2V$

**Absolute Maximum Ratings** (Note 1)

If Military/Aerospace specified devices are required, please contact the National Semiconductor Sales Office/Distributors for availability and specifications.

(Note 4)

Power Dissipation Internally limited  
Input—Output Voltage Differential +60V, -0.3V

Operating Junction Temperature Range

LM117HV -55°C to +150°C  
LM317HV 0°C to +125°C  
Storage Temperature -65°C to +150°C  
Lead Temperature (Soldering, 10 sec.) 300°C  
ESD Tolerance (Note 5) 2000V

**Electrical Characteristics** (Note 2)

Parameter	Conditions	LM117HV			LM317HV			Units
		Min	Typ	Max	Min	Typ	Max	
Line Regulation	$T_J = 25^\circ\text{C}$ , $3\text{V} \leq V_{\text{IN}} - V_{\text{OUT}} \leq 60\text{V}$ (Note 3) $I_L = 10\text{ mA}$		0.01	0.02		0.01	0.04	%/V
Load Regulation	$T_J = 25^\circ\text{C}$ , $10\text{ mA} \leq I_{\text{OUT}} \leq I_{\text{MAX}}$		0.1	0.3		0.1	0.5	%
Thermal Regulation	$T_J = 25^\circ\text{C}$ , 20 ms Pulse		0.03	0.07		0.04	0.07	%/W
Adjustment Pin Current			50	100		50	100	$\mu\text{A}$
Adjustment Pin Current Change	$10\text{ mA} \leq I_L \leq I_{\text{MAX}}$ $3.0\text{ V} \leq (V_{\text{IN}} - V_{\text{OUT}}) \leq 60\text{V}$		0.2	5		0.2	5	$\mu\text{A}$
Reference Voltage	$3.0\text{ V} \leq (V_{\text{IN}} - V_{\text{OUT}}) \leq 60\text{V}$ , (Note 4) $10\text{ mA} \leq I_{\text{OUT}} \leq I_{\text{MAX}}$ , $P \leq P_{\text{MAX}}$	1.20	1.25	1.30	1.20	1.25	1.30	V
Line Regulation	$3.0\text{V} \leq (V_{\text{IN}} - V_{\text{OUT}}) \leq 60\text{V}$ , $I_L = 10\text{ mA}$ , (Note 3)		0.02	0.05		0.02	0.07	%/V
Load Regulation	$10\text{ mA} \leq I_{\text{OUT}} \leq I_{\text{MAX}}$ (Note 3)		0.3	1		0.3	1.5	%
Temperature Stability	$T_{\text{MIN}} \leq T_J \leq T_{\text{MAX}}$		1			1		%
Minimum Load Current	$(V_{\text{IN}} - V_{\text{OUT}}) = 60\text{V}$		3.5	7		3.5	12	mA
Current Limit	$(V_{\text{IN}} - V_{\text{OUT}}) \leq 15\text{V}$ K, T Packages	1.5	2.2	3.5	1.5	2.2	3.7	A
		0.5	0.8	1.8	0.5	0.8	1.9	A
	$(V_{\text{IN}} - V_{\text{OUT}}) \leq 60\text{V}$ K, T Packages		0.3			0.3		A
			0.03			0.03		A
RMS Output Noise, % of $V_{\text{OUT}}$	$T_J = 25^\circ\text{C}$ , $10\text{ Hz} \leq f \leq 10\text{ kHz}$		0.003			0.003		%
Ripple Rejection Ratio	$V_{\text{OUT}} = 10\text{V}$ , $f = 120\text{ Hz}$ $C_{\text{ADJ}} = 10\text{ }\mu\text{F}$		65			65		dB
		66	80		66	80		dB
Long-Term Stability	$T_J = 125^\circ\text{C}$		0.3	1		0.3	1	%
Thermal Resistance, Junction to Case	H Package		12	15		12	15	$^\circ\text{C/W}$
	T Package					4	5	$^\circ\text{C/W}$
	K Package		2.3	3		2.3	3	$^\circ\text{C/W}$
Thermal Resistance, Junction to Ambient (no heat sink)	H Package		140			140		$^\circ\text{C/W}$
	T Package					50		$^\circ\text{C/W}$
	K Package		35			35		$^\circ\text{C/W}$

**Note 1:** "Absolute Maximum Ratings" indicate limits beyond which damage to the device may occur. Operating Ratings indicate conditions for which the device is functional, but do not guarantee specific performance limits.

**Note 2:** Unless otherwise specified, these specifications apply:  $-55^\circ\text{C} \leq T_J \leq +150^\circ\text{C}$  for the LM117HV, and  $0^\circ\text{C} \leq T_J \leq +125^\circ\text{C}$  for the LM317HV;  $V_{\text{IN}} - V_{\text{OUT}} = 5\text{V}$  and  $I_{\text{OUT}} = 0.1\text{A}$  for the TO-39 package and  $I_{\text{OUT}} = 0.5\text{A}$  for the TO-3 and TO-220 packages. Although power dissipation is internally limited, these specifications are applicable for power dissipations of 2W for the TO-39 and 20W for the TO-3 and TO-220.  $I_{\text{MAX}}$  is 1.5A for the TO-3 and TO-220 and 0.5A for the TO-39 package.

**Note 3:** Regulation is measured at constant junction temperature. Changes in output voltage due to heating effects must be taken into account separately. Pulse testing with low duty cycle is used.

**Note 4:** Refer to RETS117HVH or RETS117HVK for LM117HVH or LM117HVK military specifications.

**Note 5:** Human body model, 1.5 k $\Omega$  in series with 100 pF.

# Typical Performance Characteristics

Output capacitor = 0  $\mu$ F unless otherwise noted.

**Load Regulation**

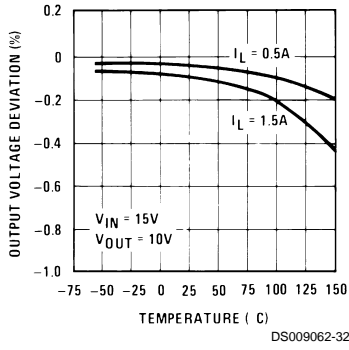

**Current Limit**

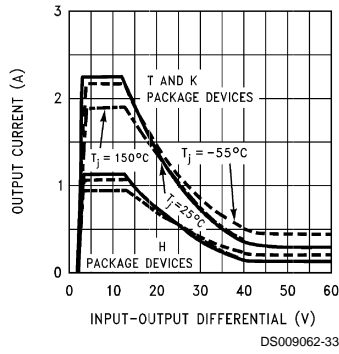

**Adjustment Current**

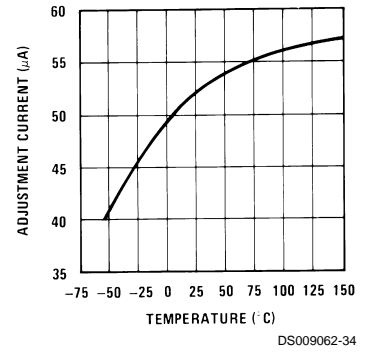

**Dropout Voltage**

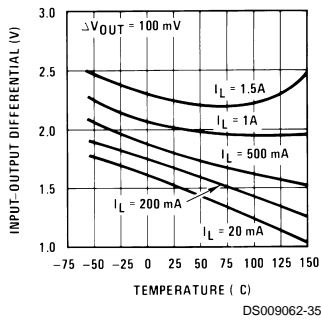

**Temperature Stability**

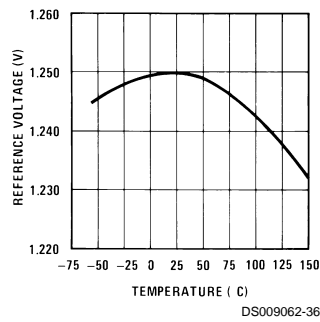

**Minimum Operating Current**

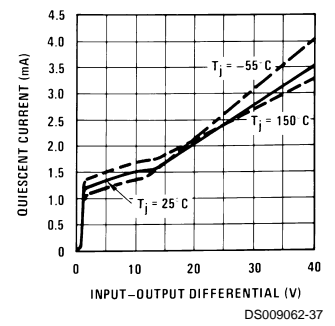

**Ripple Rejection**

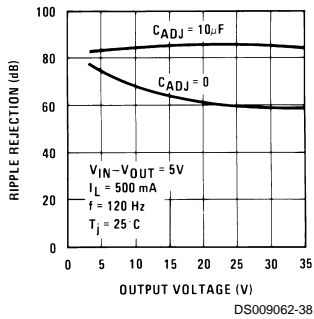

**Ripple Rejection**

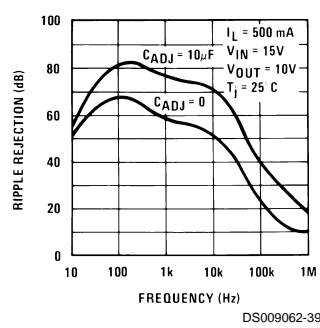

**Ripple Rejection**

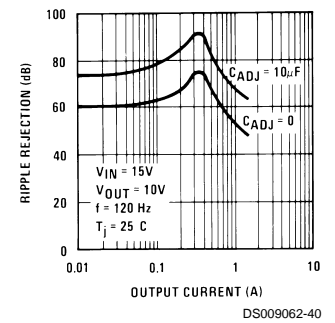

**Output Impedance**

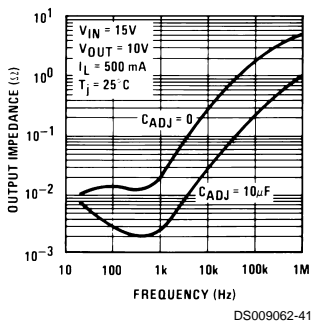

**Line Transient Response**

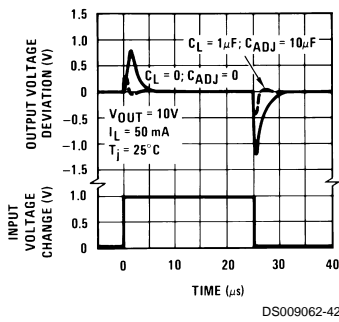

**Load Transient Response**

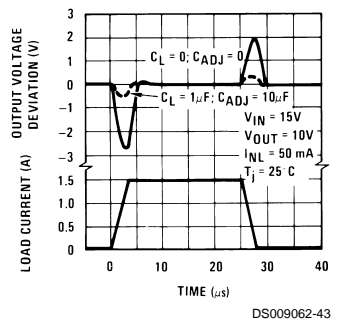

## Application Hints

In operation, the LM117HV develops a nominal 1.25V reference voltage,  $V_{REF}$ , between the output and adjustment terminal. The reference voltage is impressed across program resistor  $R1$  and, since the voltage is constant, a constant current  $I_1$  then flows through the output set resistor  $R2$ , giving an output voltage of

$$V_{OUT} = V_{REF} \left( 1 + \frac{R2}{R1} \right) + I_{ADJ}R2$$

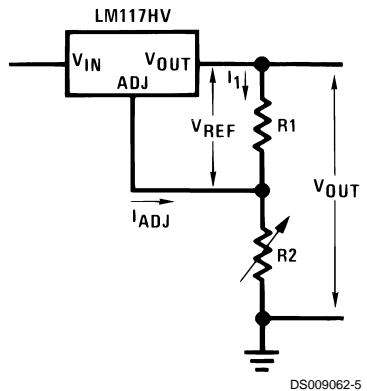

FIGURE 1.

Since the 100  $\mu$ A current from the adjustment terminal represents an error term, the LM117HV was designed to minimize  $I_{ADJ}$  and make it very constant with line and load changes. To do this, all quiescent operating current is returned to the output establishing a minimum load current requirement. If there is insufficient load on the output, the output will rise.

### External Capacitors

An input bypass capacitor is recommended. A 0.1  $\mu$ F disc or 1  $\mu$ F solid tantalum on the input is suitable input bypassing for almost all applications. The device is more sensitive to the absence of input bypassing when adjustment or output capacitors are used but the above values will eliminate the possibility of problems.

The adjustment terminal can be bypassed to ground on the LM117HV to improve ripple rejection. This bypass capacitor prevents ripple from being amplified as the output voltage is increased. With a 10  $\mu$ F bypass capacitor 80 dB ripple rejection is obtainable at any output level. Increases over 10  $\mu$ F do not appreciably improve the ripple rejection at frequencies above 120 Hz. If the bypass capacitor is used, it is sometimes necessary to include protection diodes to prevent the capacitor from discharging through internal low current paths and damaging the device.

In general, the best type of capacitors to use are solid tantalum. Solid tantalum capacitors have low impedance even at high frequencies. Depending upon capacitor construction, it takes about 25  $\mu$ F in aluminum electrolytic to equal 1  $\mu$ F solid tantalum at high frequencies. Ceramic capacitors are also good at high frequencies; but some types have a large decrease in capacitance at frequencies around 0.5 MHz. For this reason, 0.01  $\mu$ F disc may seem to work better than a 0.1  $\mu$ F disc as a bypass.

Although the LM117HV is stable with no output capacitors, like any feedback circuit, certain values of external capacitance can cause excessive ringing. This occurs with values between 500 pF and 5000 pF. A 1  $\mu$ F solid tantalum (or 25  $\mu$ F aluminum electrolytic) on the output swamps this effect and

insures stability. Any increase of load capacitance larger than 10  $\mu$ F will merely improve the loop stability and output impedance.

### Load Regulation

The LM117HV is capable of providing extremely good load regulation but a few precautions are needed to obtain maximum performance. The current set resistor connected between the adjustment terminal and the output terminal (usually 240 $\Omega$ ) should be tied directly to the output of the regulator rather than near the load. This eliminates line drops from appearing effectively in series with the reference and degrading regulation. For example, a 15V regulator with 0.05 $\Omega$  resistance between the regulator and load will have a load regulation due to line resistance of 0.05 $\Omega$   $\times$   $I_L$ . If the set resistor is connected near the load the effective line resistance will be 0.05 $\Omega$  (1 +  $R2/R1$ ) or in this case, 11.5 times worse.

Figure 2 shows the effect of resistance between the regulator and 240 $\Omega$  set resistor.

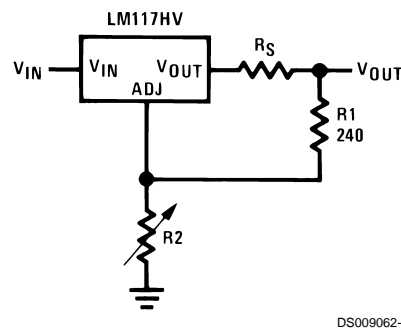

FIGURE 2. Regulator with Line Resistance in Output Lead

With the TO-3 package, it is easy to minimize the resistance from the case to the set resistor, by using two separate leads to the case. However, with the TO-5 package, care should be taken to minimize the wire length of the output lead. The ground of  $R2$  can be returned near the ground of the load to provide remote ground sensing and improve load regulation.

### Protection Diodes

When external capacitors are used with any IC regulator it is sometimes necessary to add protection diodes to prevent the capacitors from discharging through low current points into the regulator. Most 10  $\mu$ F capacitors have low enough internal series resistance to deliver 20A spikes when shorted. Although the surge is short, there is enough energy to damage parts of the IC.

When an output capacitor is connected to a regulator and the input is shorted, the output capacitor will discharge into the output of the regulator. The discharge current depends on the value of the capacitor, the output voltage of the regulator, and the rate of decrease of  $V_{IN}$ . In the LM117HV, this discharge path is through a large junction that is able to sustain 15A surge with no problem. This is not true of other types of positive regulators. For output capacitors of 25  $\mu$ F or less, there is no need to use diodes.

The bypass capacitor on the adjustment terminal can discharge through a low current junction. Discharge occurs when either the input or output is shorted. Internal to the LM117HV is a 50 $\Omega$  resistor which limits the peak discharge current. No protection is needed for output voltages of 25V

## Application Hints (Continued)

or less and 10  $\mu\text{F}$  capacitance. *Figure 3* shows an LM117HV with protection diodes included for use with outputs greater than 25V and high values of output capacitance.

### Current Limit

Internal current limit will be activated whenever the output current exceeds the limit indicated in the Typical Performance Characteristics. However, if during a short circuit condition the regulator's differential voltage exceeds the Absolute Maximum Rating of 60V (e.g.  $V_{IN} \geq 60\text{V}$ ,  $V_{OUT} = 0\text{V}$ ), internal junctions in the regulator may break down and the device may be damaged or fail. Failure modes range from an apparent open or short from input to output of the regulator, to a destroyed package (most common with the TO-220 package). To protect the regulator, the user is advised to be aware of voltages that may be applied to the regulator during fault conditions, and to avoid violating the Absolute Maximum Ratings.

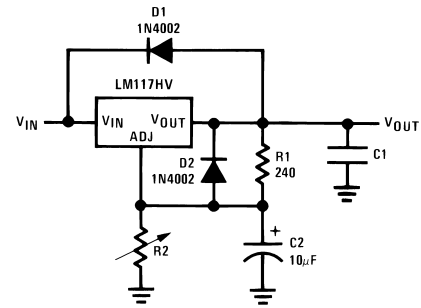

DS009062-7

FIGURE 3. Regulator with Protection Diodes

$$V_{OUT} = 1.25V \left( 1 + \frac{R_2}{R_1} \right) + I_{ADJ}R_2$$

**Note:** D1 protects against C1  
D2 protects against C2

## Schematic Diagram

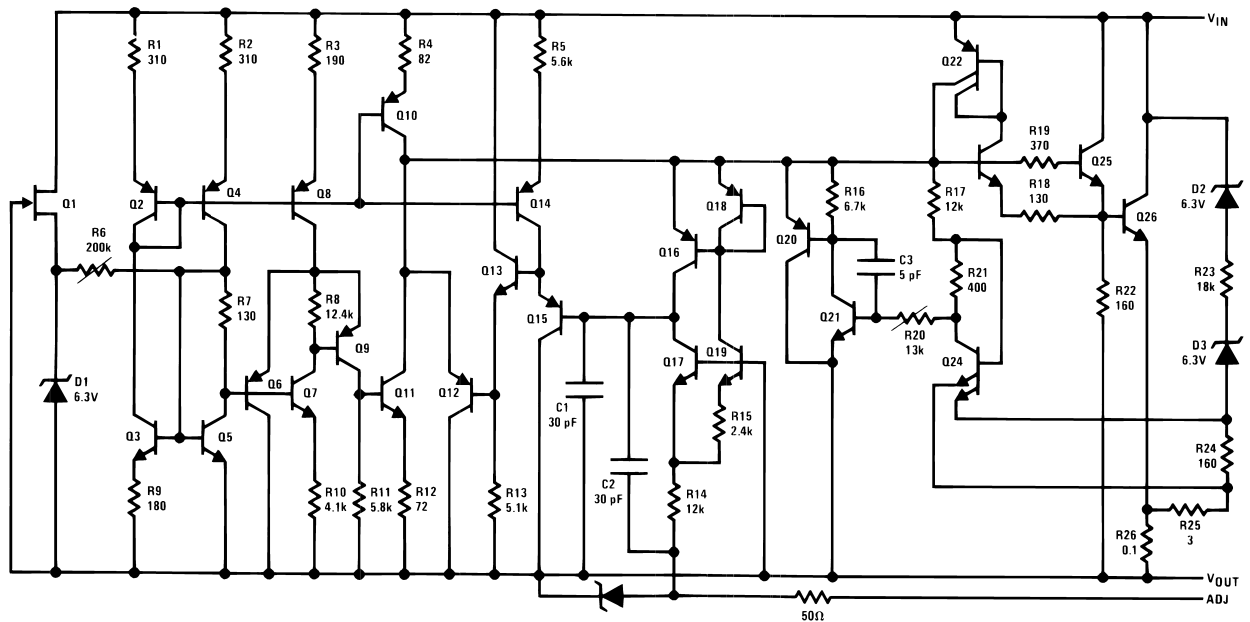

DS009062-8

## Typical Applications

### Slow Turn-On 15V Regulator

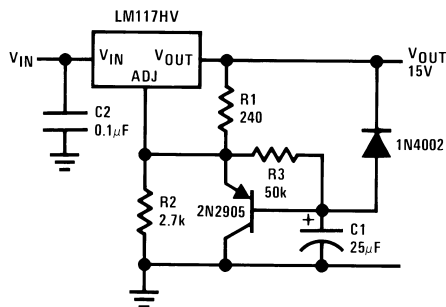

DS009062-9

### Adjustable Regulator with Improved Ripple Rejection

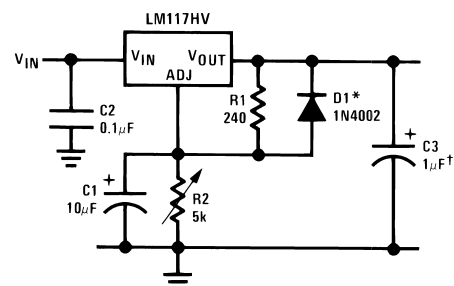

DS009062-10

†Solid tantalum

\*Discharges C1 if output is shorted to ground

# Typical Applications (Continued)

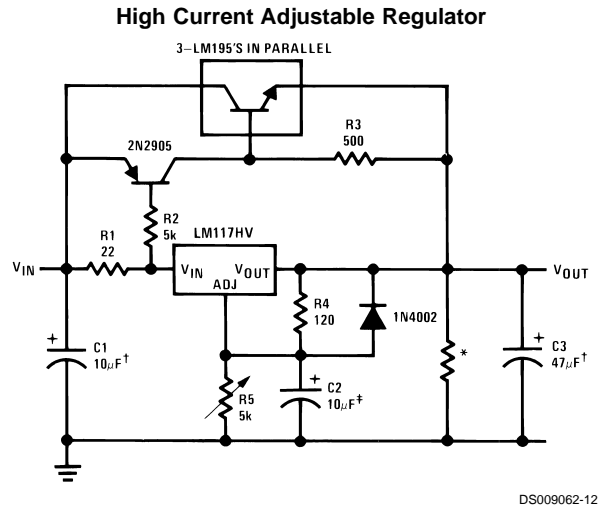
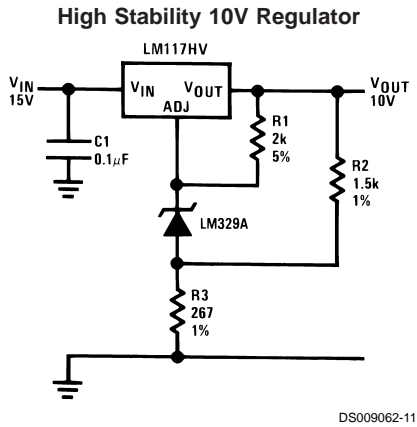

†Solid tantalum  
 \*Minimum load current = 30 mA  
 ‡Optional — improves ripple rejection

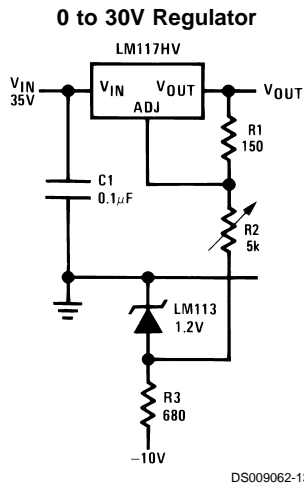

Full output current not available at high input-output voltages

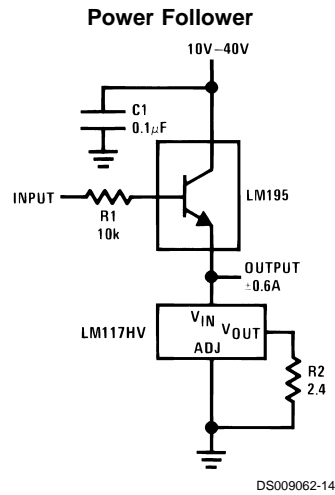

Typical Applications (Continued)

5A Constant Voltage/Constant Current Regulator

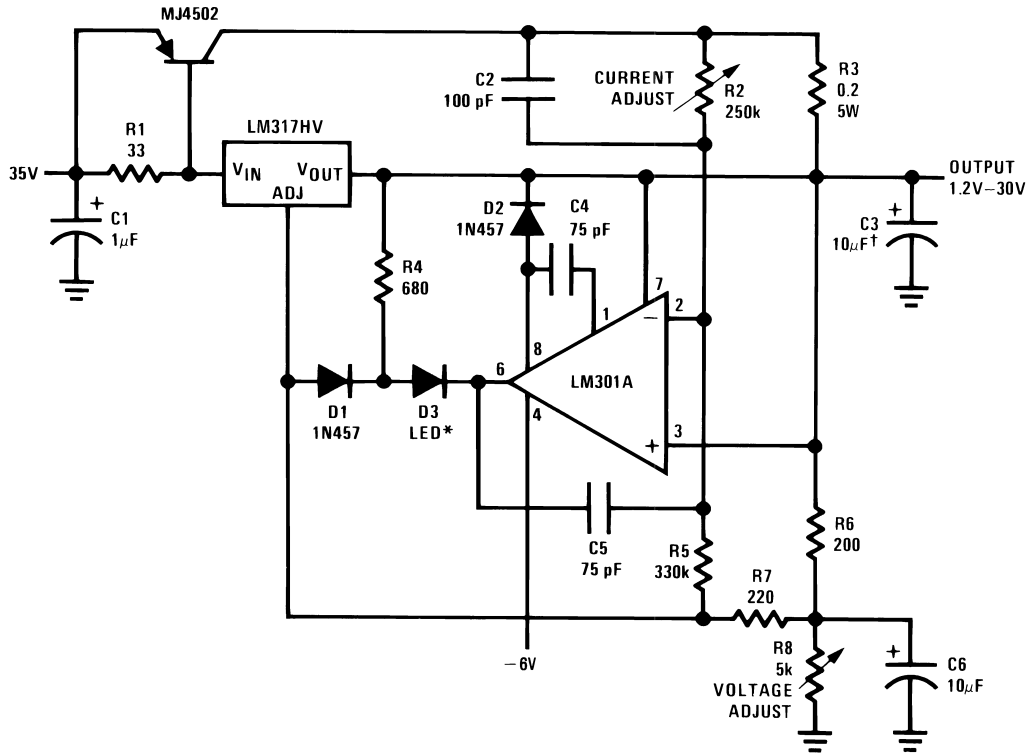

DS009062-15

†Solid tantalum  
\*Lights in constant current mode

1A Current Regulator

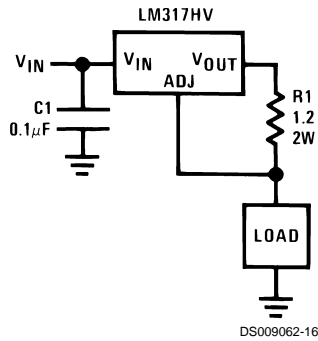

DS009062-16

1.2V-20V Regulator with Minimum Program Current

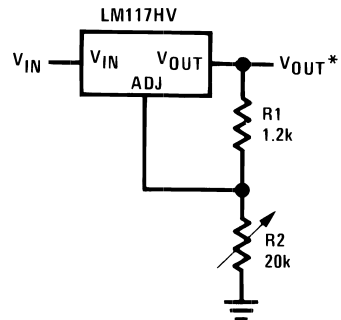

DS009062-17

\*Minimum load current ≈ 4 mA



# Typical Applications (Continued)

### High Gain Amplifier

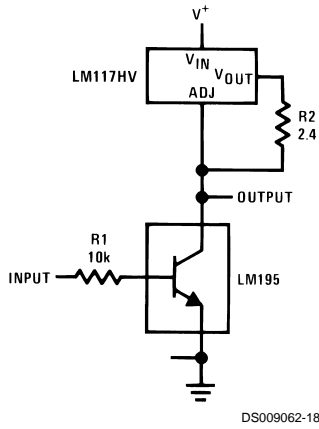

### Low Cost 3A Switching Regulator

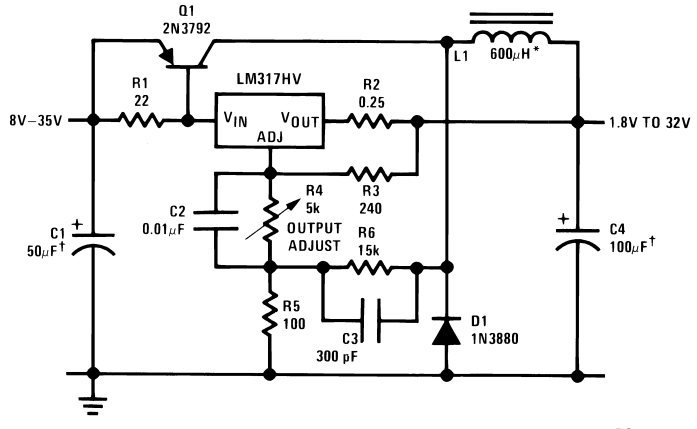

†Solid tantalum  
\*Core—Arnold A-254168-2 60 turns

### 4A Switching Regulator with Overload Protection

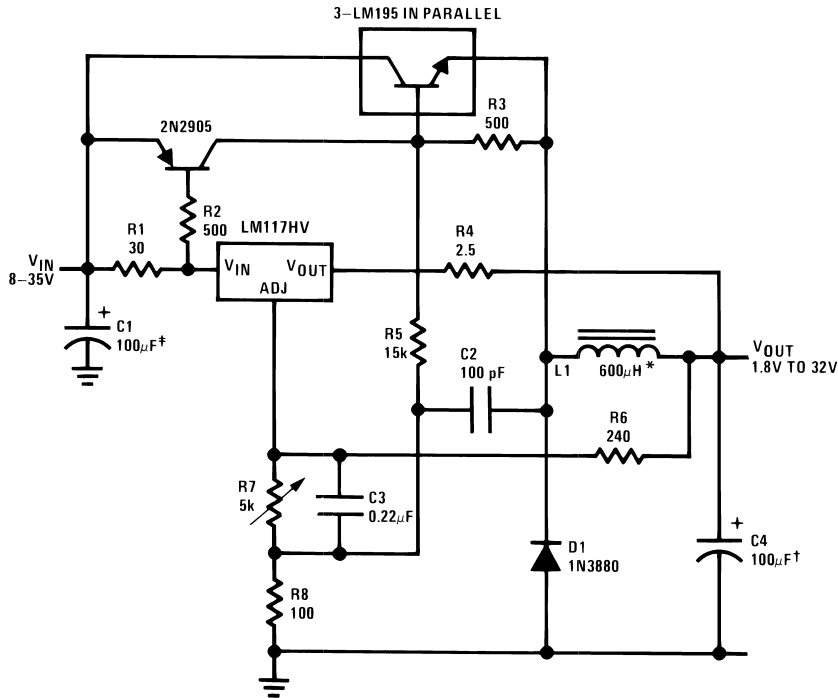

†Solid tantalum  
\*Core—Arnold A-254168-2 60 turns

## Typical Applications (Continued)

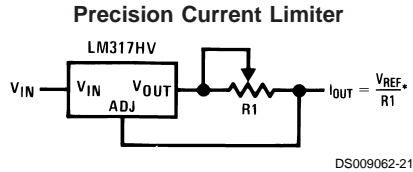

\*  $0.8\Omega \leq R_1 \leq 120\Omega$

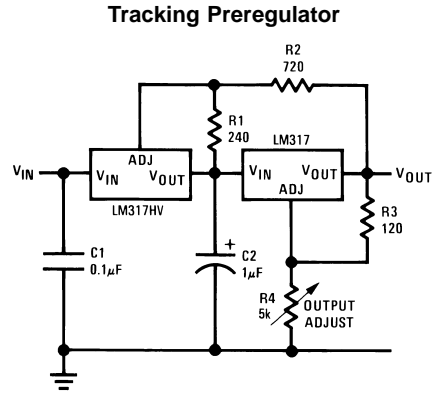

### Adjustable Multiple On-Card Regulators with Single Control\*

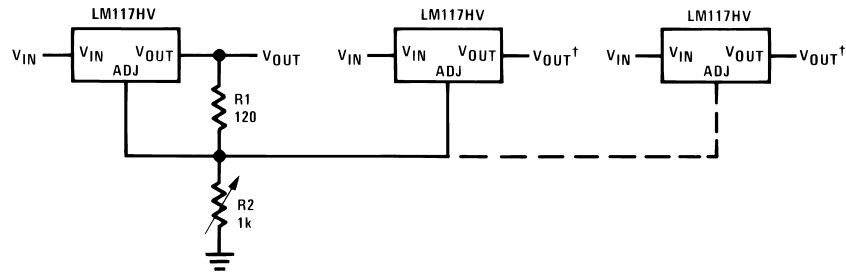

\*All outputs within  $\pm 100$  mV

†Minimum load — 10 mA

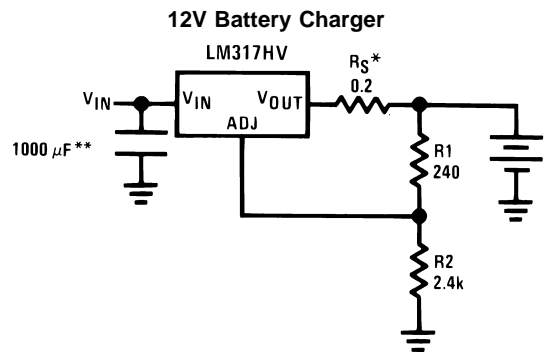
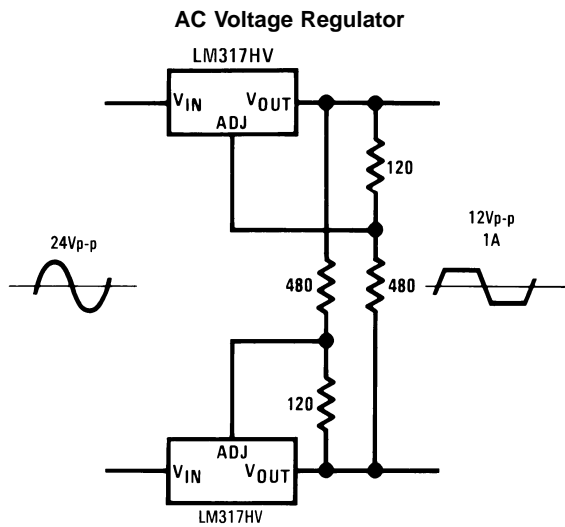

\* $R_S$ —sets output impedance of charger  $Z_{OUT} = R_S \left( 1 + \frac{R_2}{R_1} \right)$

Use of  $R_S$  allows low charging rates with fully charged battery.  
 \*\*The 1000  $\mu F$  is recommended to filter out input transients

# Typical Applications (Continued)

50 mA Constant Current Battery Charger

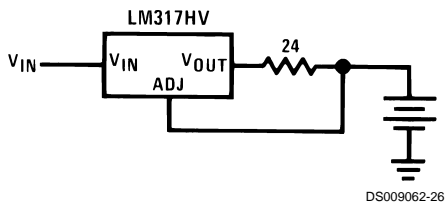

Adjustable 4A Regulator

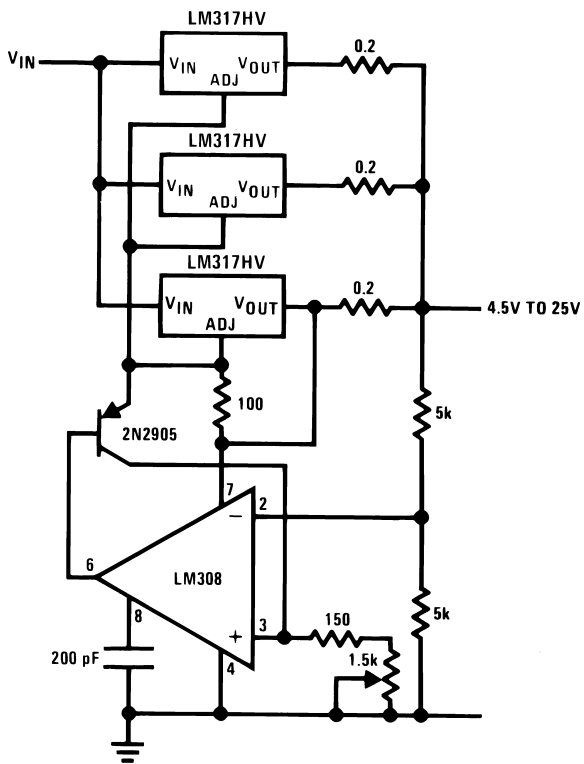

Current Limited 6V Charger

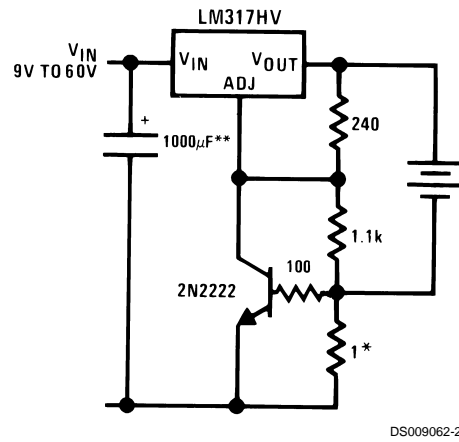

\*Sets peak current (0.6A for 1Ω)

\*\*The 1000 μF is recommended to filter out input transients

**Connection Diagrams** (See Physical Dimension section for further information)

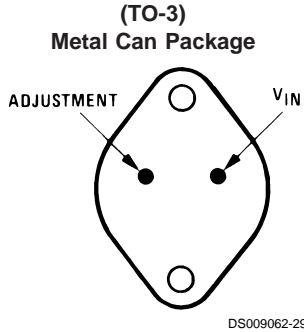

**Case is Output  
Bottom View**  
Order Number LM117HVKSTL/883  
See NS Package Number K02C  
Order Number LM317HVK STEEL  
See NS Package Number K02A

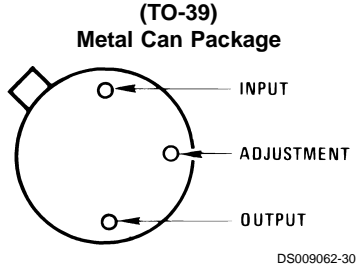

**Case is Output  
Bottom View**  
Order Number LM117HVH,  
LM117HVH/883  
or LM317HVH  
See NS Package Number H03A

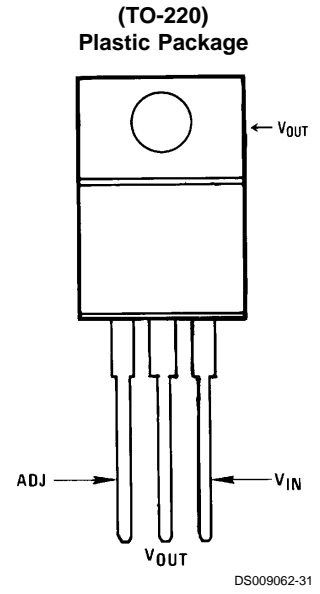

**Front View**  
Order Number LM317HVT  
See NS Package Number T03B

**Physical Dimensions** inches (millimeters) unless otherwise noted

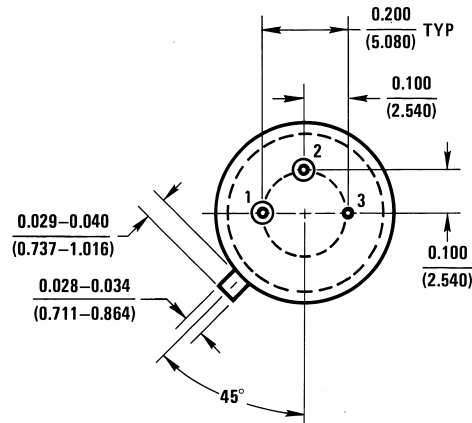
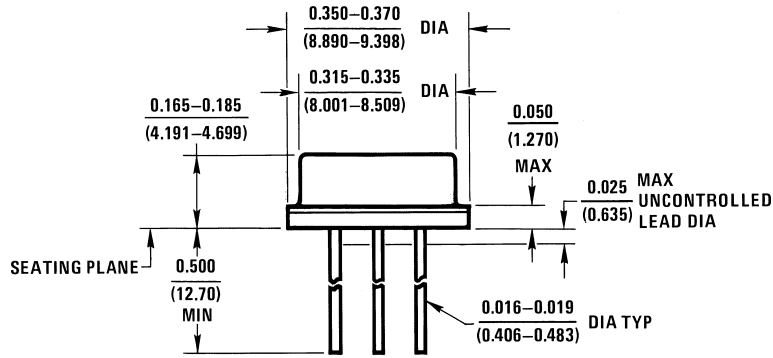

H03A (REV B)

**Order Number LM117HVH, LM117HVH/883, or LM317HVH**  
**NS Package Number H03A**

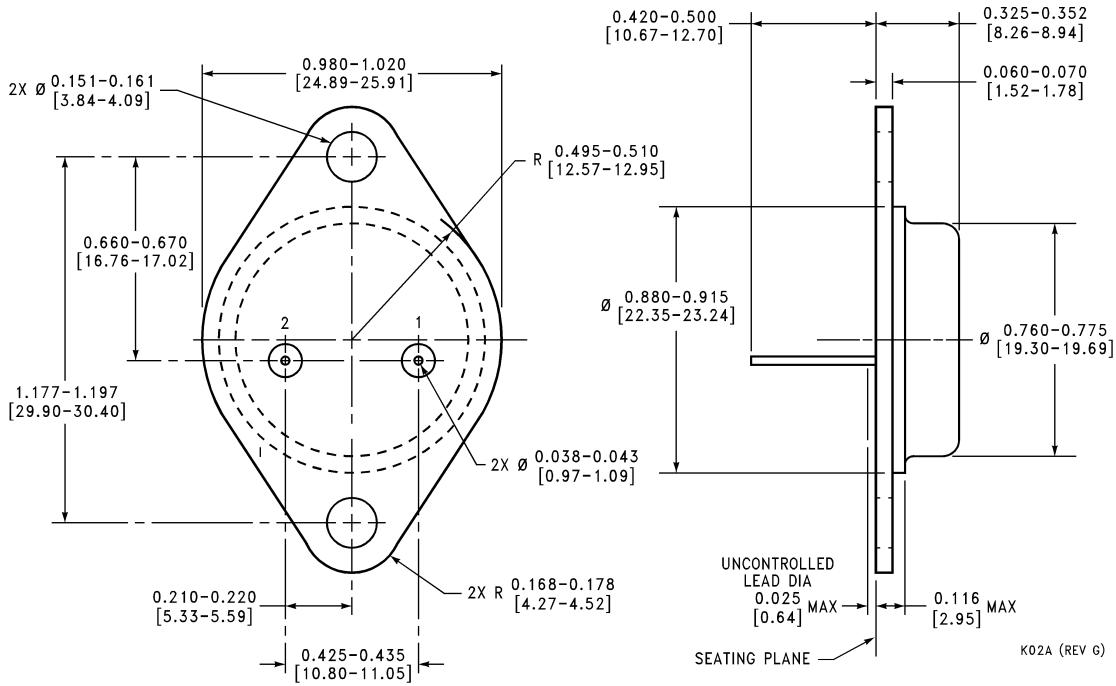

**Metal Can Package (K)**  
**Order Number LM317HVK STEEL**  
**NS Package Number K02A**

**Physical Dimensions** inches (millimeters) unless otherwise noted (Continued)

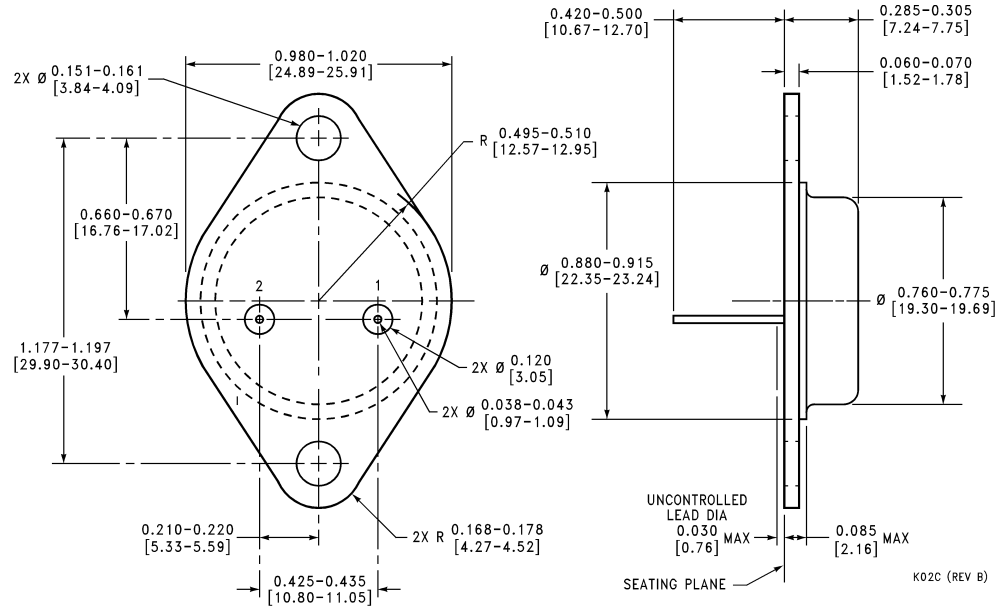

**Metal Can Package (K)**  
**Mil-Aero Product**  
**Order Number LM117HVKSTL/883**  
**NS Package Number K02C**

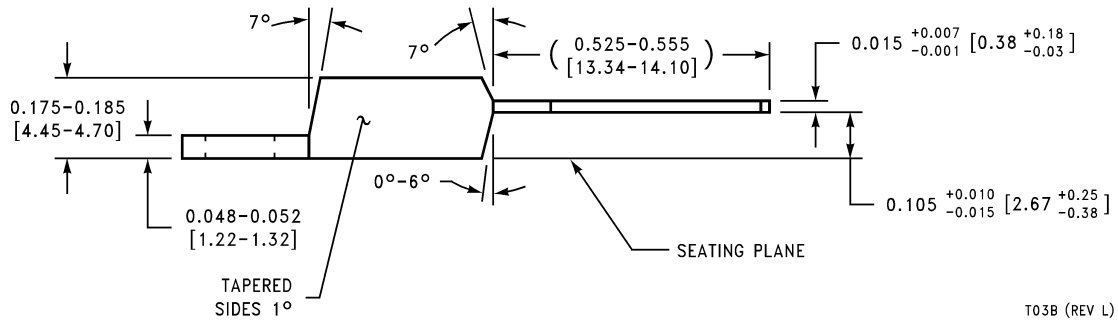
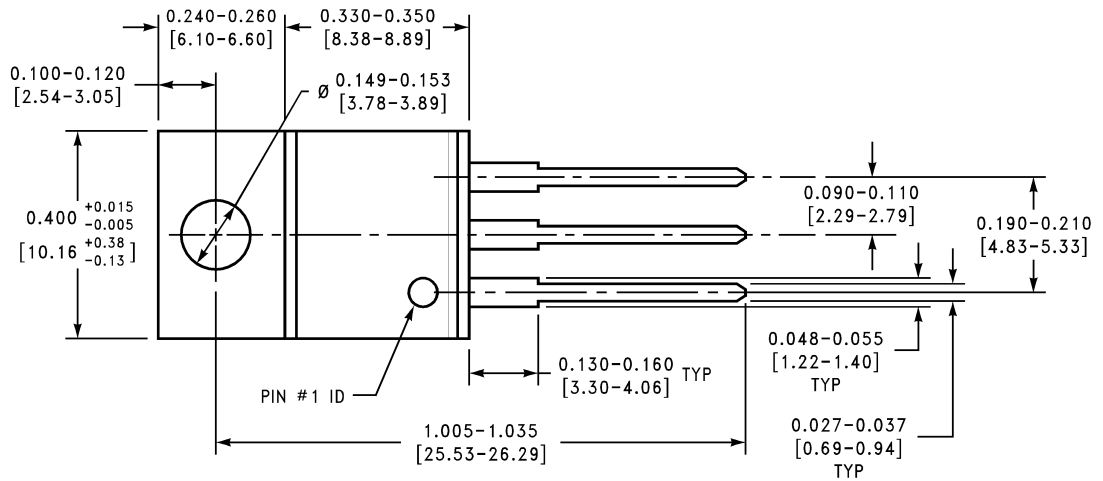

**Order Number LM317HVT**  
**NS Package Number T03B**

## Notes

### LIFE SUPPORT POLICY

NATIONAL'S PRODUCTS ARE NOT AUTHORIZED FOR USE AS CRITICAL COMPONENTS IN LIFE SUPPORT DEVICES OR SYSTEMS WITHOUT THE EXPRESS WRITTEN APPROVAL OF THE PRESIDENT AND GENERAL COUNSEL OF NATIONAL SEMICONDUCTOR CORPORATION. As used herein:

1. Life support devices or systems are devices or systems which, (a) are intended for surgical implant into the body, or (b) support or sustain life, and whose failure to perform when properly used in accordance with instructions for use provided in the labeling, can be reasonably expected to result in a significant injury to the user.
2. A critical component is any component of a life support device or system whose failure to perform can be reasonably expected to cause the failure of the life support device or system, or to affect its safety or effectiveness.



[www.national.com](http://www.national.com)