

White LED PFM Step-Up DC-DC Converter

Outline:

The BL8532 is a PFM step-up DC-DC converter specifically designed to drive white LEDs with a constant current. It can deliver stable constant output current from 0mA to 500mA by adjusting the external resistor.

The BL8532 can drive one or more LEDs in parallel connection, also it can drive two in series, several in parallel connection from one or two battery cells. With overvoltage limit protection circuit interiorly, the chip and the external circuits will be safe even if the load is not connected. The device also can deliver steady constant output voltage from 2.5V to 6.0V by adjusting the external resistor.

The BL8532 integrates stable reference circuits and it uses trimming technology in the process, so it can afford high precision and low temperature-drift coefficient output current or output voltage.

The BL8532 devices are available in SOT-89-5 package.

Features:

- Low start-up voltage (when the output current is 1mA)-----0.8V
- The converter can output constant voltage from 2.5V to 6.0V or it can output constant current from 0 to 500mA by adjusting the external resistor.
- Output current accuracy -----±10%
- Low temperature-drift coefficient of the output current-----±100ppm/°C
- Only four external components are necessary: an inductor, a Schottky diode, an output filter capacitor and a resistor.
- High conversion efficiency (When $V_{in}=2.5V$, for 1W LED)-----80%

Applications:

- Power source for white LED
- Supply constant current
- Power source for a single or dual-cell battery-powered equipments

Selection guide:

BL8532-XX X XX

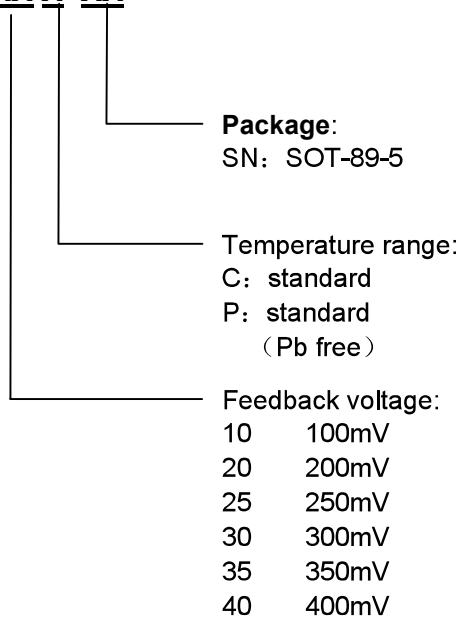

Pin configuration:

Pin No.	Symbol	Description
1	IFB	Current feedback pin
2	Vout	Output pin, power supply for internal circuits
3	CE	Chip enable pin (active high)
4	Lx	Switching pin(Nch open drain)
5	GND	Ground pin

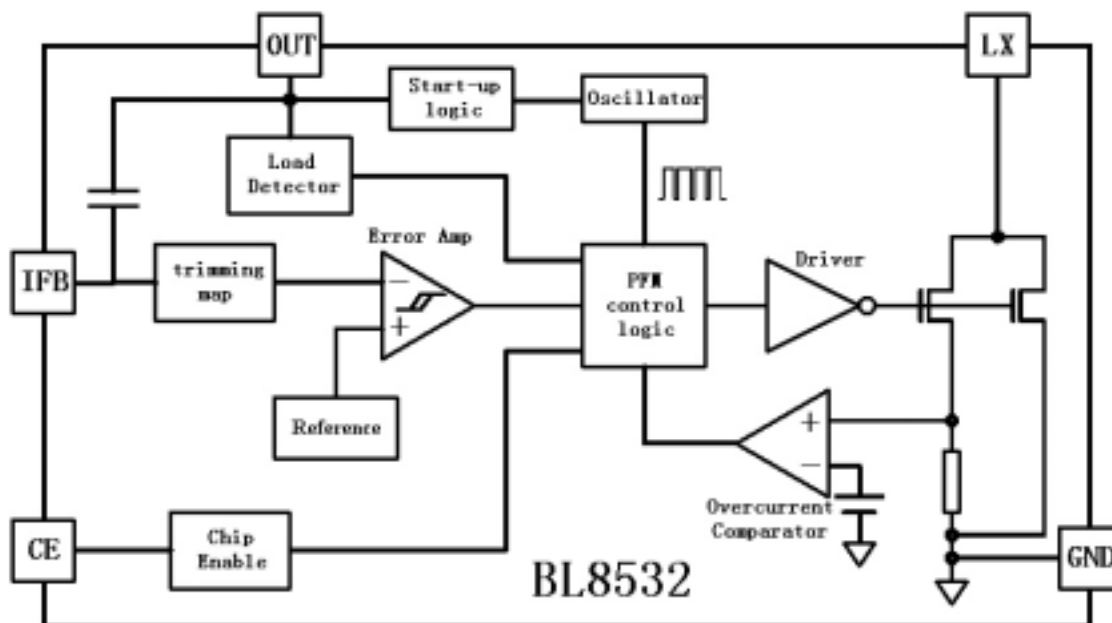
Functional block diagram :

Absolute maximum ratings:

Input voltage range	-----	-0.3V~10V
LX pin voltage	-----	-0.3V~(Vout+0.3)
CE pin voltage	-----	-0.3V~(Vout+0.3)
IFB pin voltage	-----	-0.3V~(Vout+0.3)
Lx pin output current	-----	1.5A
Maximum power dissipation: Pd@T=25°C		
SOT-89-5	-----	0.5W
Maximum junction temperature	-----	150°C
Operating free-air temperature range	-----	-20°C ~+85°C
Storage temperature range	-----	-40°C ~125°C
Lead temperature and time	-----	260°C, 10S

Recommended operating conditions:

	MIN	NOM	MAX	UNIT
Input voltage range	0.8		Vout	V
inductor	10	22	100	μH
Input capacitor	0	≥22		μF
Output capacitor*	47	100	220	μF
Compensation capacitor*	10	22	47	μF
Operating junction temperature	-20		85	°C

* **Suggestion:** Tantalum capacitor is recommended to reduce the ripple of the output voltage.

Electrical characteristics:

 ($V_{in}=2.5V$, $V_{CE}=V_{out}=3.3V$, $R=33\Omega$, $T_A=25^\circ C$, unless otherwise noted.)

Symbol	Item	Test conditions	Reference data			Unit
			Min	Typ.	Max	
V_{IFB}	Feedback voltage	$I_{out}=100mA$	80	100	120	mV
			180	200	220	
			230	250	270	
			280	300	320	
			330	350	370	
			380	400	420	
V_{start}	Start-up voltage	$I_{out}=1mA$, $V_{in}: 0 \rightarrow 2V$		0.8	0.9	V
V_{hold}	Hold-on voltage	$I_{out}=1mA$, $V_{in}: 2 \rightarrow 0V$	0.6	0.7		V
I_{DD2}^{*5}	Quiescent current drawn from power source	LX hung in air, $V_{CE}=V_{IFB}=$ $V_{out}=3.3V$, $V_{in}=2.5V$		20	30	μA
$I_{no load}^{*6}$	Current with no load	OUT pin and IFB pin without any load, $V_{IFB}=0$		100	150	μA
I_{LX}	LX switching current	$V_{LX}=0.4V$, $V_{IFB}=0$	700			mA
$I_{LX leak}$	LX leakage current	$V_{out}=V_{LX}=V_{IFB}=6V$,			1	μA
I_{leak}	Stand-by current	$V_{out}=3.3V$, $V_{CE}=0$, LX、IFB hung in air		< 0.1	0.5	μA
F_{osc}	Oscillator frequency	$V_{IFB}=0$,	300	350	400	KHZ
$Maxdty$	Oscillator duty cycle	On (VLX “L”) side	70	75	80	%
η	Efficiency	$I_{out}=300mA$		80		%
V_{CEH}	CE “H” threshold voltage	$V_{CE}: 0 \rightarrow 2V$	0.6	0.9		V
V_{CEL}	CE “L” threshold voltage	$V_{CE}: 2 \rightarrow 0V$		0.3	0.6	V
V_{OM}	Maximum output voltage (with no load)	No load between OUT pin and IFB pin, $V_{in} < V_{out}$	7.0	7.2	7.4	V
I_{OM}	Maximum output current	$V_{IFB}=0$, $V_{out} \equiv 3.3V$		500		mA

Note:

- 1、Diode: schottky type, such as:1N5817,1N5819,1N5822
- 2、Inductor: 22 μH ($R < 0.5\Omega$)
- 3、Capacitor: 100 μF (Tantalum type)
- 4、Compensation capacitor: 22 μF (Tantalum type)
- 5、 I_{DD2} is quiescent current drawn from power source, It is the minimum current of the chip without any dynamic current.
- 6、 $I_{no load}$ is the current with no load in constant current application, it's also the current consumed by the converter itself, including the chip and external circuits, when $V_{in}=2.5V$, $V_{out}=V_{OM}$.

Typical applications:

(1) Constant output current application

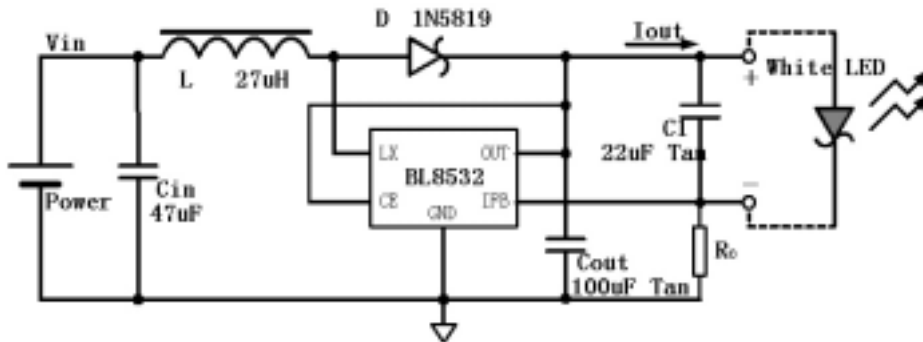

(A) Drive only one white LED

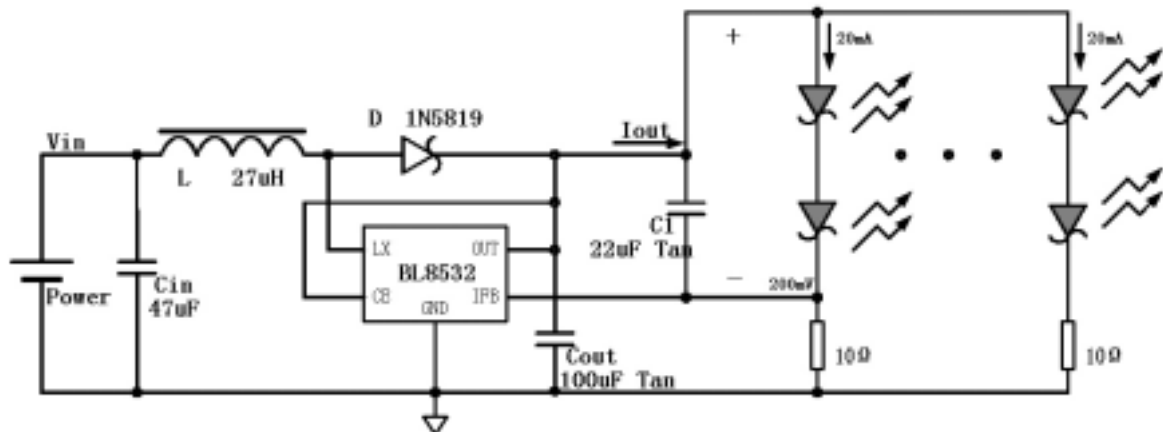

(B) Drive two white-LED in series and several in parallel connection

(2) Constant output voltage application

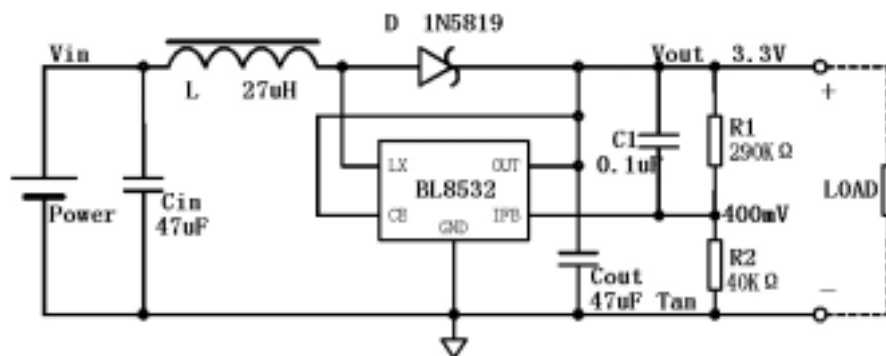

Detailed description:

The BL8532 series are boost structure, voltage-type pulse-frequency modulation (PFM) step-up DC-DC converter. It can deliver constant current or constant voltage. In constant current application, only five external components are necessary to supply output current from 0 to 500mA: an inductor, an output filter capacitor, a shottky diode, a compensation capacitor and a resistor which adjusts the output current. In constant voltage application, to deliver adjustable and low noise output voltage from 2.0V to 6.0V, only six external components are necessary as well: an inductor, a output filter capacitor, a shottky diode, a compensation capacitor and two resistors for output voltage detect. The BL8532 device consists of resistors for output voltage detection and trimming, a start-up voltage circuit, an oscillator, a reference circuit, a PFM control circuit, a switch protection circuit, a voltage limit protection circuit and a driver transistor.

- How to determine Rc in constant current application condition:

We define output current is I_{out} , then Rc can be determined by $R_c = \frac{V_{IFB}}{I_{out}}$.

For example, if we need $I_{out}=100\text{mA}$, and we choose the chip of $V_{IFB}=200\text{mV}$, thus $R_c=200\text{mV}/100\text{mA}=2\Omega$.

- How to determine R1, R2 in constant voltage application :

We define output voltage is V_{out} , then $\frac{R1}{R2} = \frac{V_{out}}{V_{IFB}} - 1$, R2 is in the range of $1\text{K}\Omega\sim 100\text{K}\Omega$.

If we need $V_{out}=3.3\text{V}$, and we choose the BL8532 of $V_{IFB}=400\text{mV}$ and select $R2=4\text{K}\Omega$, thus $R1=29\text{K}\Omega$.

In constant voltage application, we suggest using the high VIFB type BL8532, because there is voltage ripple in existence on feedback voltage. When VIFB is high, the infection of the ripple is less than that of low VIFB type, so the output is more stable.

The PFM control circuit is the core of the BL8532 IC. This block controls power switch on/off duty cycle to stabilize output voltage by calculating results of other blocks which sense input voltage, output voltage, output current and load conditions. In PFM modulation system, the frequency and pulse width is fixed. The duty cycle is adjusted by skipping pulses, so that switch on-time is changed based on the conditions such as input voltage, output current and load. The oscillate block inside BL8532 provides fixed frequency and pulse width wave.

High-gain differential error amplifier guarantees stable output voltage at difference input voltage and load. In order to reduce ripple and noise, the error amplifier is designed with high bandwidth.

Though at very low load condition, the quiescent current of chip do affect efficiency certainly. The four main energy loss of Boost structure DC-DC converter in full load are the ESR of inductor, the voltage of Schottky diode, on resistor of internal N-channel MOSFET and its driver. In order to improve the efficiency, BL8532 integrates low on-resistor N-channel MOSFET and well designed driver circuits. The switch energy loss is limited at very low level.

Selection of the external components:

Thus it can be seen, the inductor and shottky diode affect the conversion efficiency greatly. The inductor and the capacitor also have great influence on the output voltage ripple of the converter. So it is necessary to choose a suitable inductor, a capacitor and a right shottky diode, to obtain high efficiency, low ripple and low noise.

Before discussion, we define:
$$D \equiv \frac{V_{out} - V_{in}}{V_{out}}$$

(1) Inductor Selection

Above all, we should define the minimum value of the inductor that can ensure the boost DC-DC to operate in the continuous current-mode condition.

$$L_{min} \geq \frac{D(1-D)^2 R_L}{2f}$$

The above expression is got under conditions of continuous current mode, neglect Schottky diode's voltage, ESR of both inductor and capacitor. The actual value is greater than it. If inductor's value is less than L_{min} , the efficiency of DC-DC converter will drop greatly, and the DC-DC circuit will not be stable.

Secondly, consider the ripple of the output voltage,

$$\Delta I = \frac{D \cdot V_{in}}{Lf}$$

$$I_{max} = \frac{V_{in}}{(1-D)^2 R_L} + \frac{DV_{in}}{2Lf}$$

If inductor value is too small, the current ripple through it will be great. Then the current through diode and power switch will be great. Because the power switch on chip is not ideal switch, the energy of switch will improve. The efficiency will fall.

Thirdly, in general, smaller inductor values supply more output current while larger values start up with lower input voltage and acquire high efficiency.

An inductor value of 3uH to 1mH works well in most applications. If DC-DC converter delivers large output current (for example: output current is great than 50mA), large inductor value is recommended in order to improve efficiency. If DC-DC must output very large current at low input supply voltage, small inductor value is recommended.

The ESR of inductor will affect efficiency greatly. Suppose ESR value of inductor is r_L , R_{load} is load resistor, then the energy can be calculated by following expression :

$$\Delta \eta \approx \frac{r_L}{R_{load}(1-D)^2}$$

For example: input 1.5V, output is 3.0V, $R_{load}=20\Omega$, $r_L=0.5\Omega$, The energy loss is 10%.

Consider all above, inductor value of 47uH、ESR<0.5Ω is recommended in most applications. Large value is recommended in high efficiency applications and smaller value is recommended

(2) Capacitor Selection

Ignore ESR of capacitor, the ripple of output voltage is:

$$r = \frac{\Delta V_{out}}{V_{out}} = \frac{D}{R_{load} Cf}$$

So large value capacitor is needed to reduce ripple. But too large capacitor value will slow down system reaction and cost will improve. So 100uF capacitor is recommended. Larger capacitor value will be used in large output current system. If output current is small (<10mA), small value is needed.

Consider ESR of capacitor, ripple will increase:

$$r' = r + \frac{I_{max} \cdot R_{ESR}}{V_{out}}$$

When current is large, ripple caused by ESR will be main factor. It may be greater than 100mV. The ESR will affects efficiency and increase energy loss. So low-ESR capacitor (for example: tantalum capacitor) is recommend or connect two or more filter capacitors in parallel.

(3) Diode Selection

Rectifier diode will affects efficiency greatly, Though a common diode (such as 1N4148) will work well for light load, it will reduce about 5%~10% efficiency for heavy load, For optimum performance, a Schottky diode (such as 1N5817、1N5819、1N5822) is recommended.

(4) Input Capacitor

If supply voltage is stable, the DC-DC circuit can output low ripple, low noise and stable voltage without input capacitor. If voltage source is far away from DC-DC circuit, input capacitor value greater than 10uF is recommended.

(5) Resistor R1、R2 for output voltage detect

In constant current application, R1 and R2 can be selected by following expression :

$$\frac{V_{out}}{V_{IFB}} = \frac{R1}{R2} + 1$$

For example, when $V_{IFB}=400mV$, $V_{out}=3.3V$,

If $R2=4K\Omega$, then $R1 = (\frac{V_{out}}{V_{IFB}} - 1) \times R2 = 29K\Omega$; if $R2=40K\Omega$, then $R1=290 K\Omega$.

(6) Selection of L、C and compensation capacitor C1

When the load current is large (eg: $I_{out}=100mA$), the output voltage ripple will increase:

$$\Delta V_{out} \approx \sqrt{\frac{L}{C} I_L^2 + V_{out}^2} - V_{out}$$

As we can see, When output current is large, the maximum current of the inductor I_L will increase, thus the ripple of the output voltage will increase. To decrease the ripple, there are two ways:

Firstly, select the appropriate value of L、C. It require the value of $L \cdot C$ be not too large, and the value of L/C be small. For example, select $L=22\mu H$, $C=100\mu F$; or $L=10\mu H$, $C=47\mu F$; etc.

If select $L/C > 1$ (such as $L=100\mu H$, $C=47\mu F$), it is improper in large current (larger than 100mA) application.

Secondly, add a compensation capacitor C1 to reduce the ripple. However, the value of the compensation capacitor is different between constant current application and constant voltage mode. C1 and the resistor parallel connected with it will generate a pole, thus, it can compensate the syntonc frequency made by L、C.

In constant voltage mode, if the resistor parallel connected with C1 is large, (eg: $R1=290K\Omega$) then $\tau=R1 \cdot C1$ is large, therefore, when $C1 \geq 0.1\mu F$, the ripple can be decreased greatly.

But in constant current mode, the resistor parallel connected with C1 is just the equivalent resistor of the white-LED, about 1Ω. Then, to maintain larger τ require larger compensation capacitor, normally between 10uF to 47uF. Many experiments have proved, when $L=22\mu\text{H}$, $C_{out}=100\mu\text{F}$, $C_1=22\mu\text{F}$, the ripple of the output voltage, the output current, and the feedback voltage is smallest, and the characteristic of the constant current is excellent, even the efficiency is highest.

Test circuits:

(1) Feedback voltage test circuit

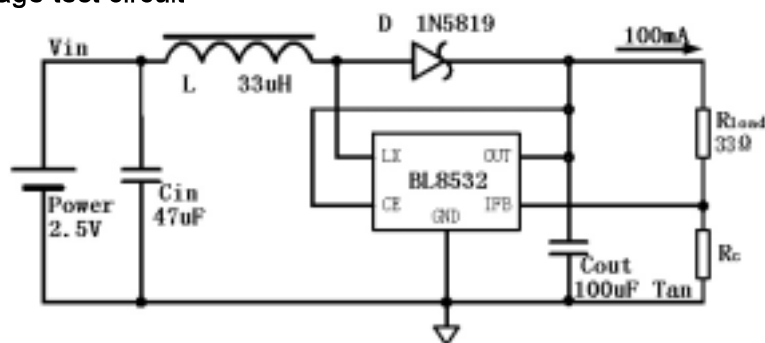
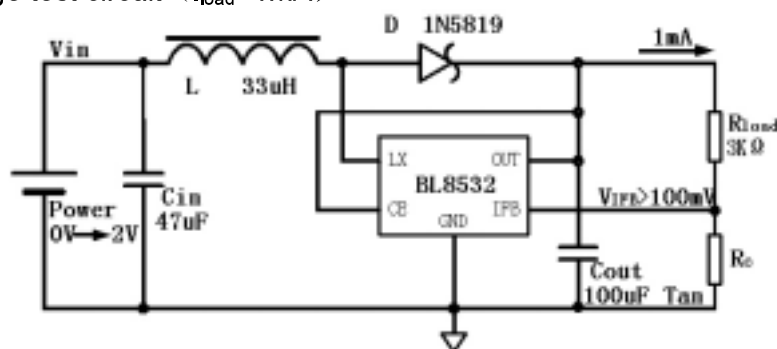
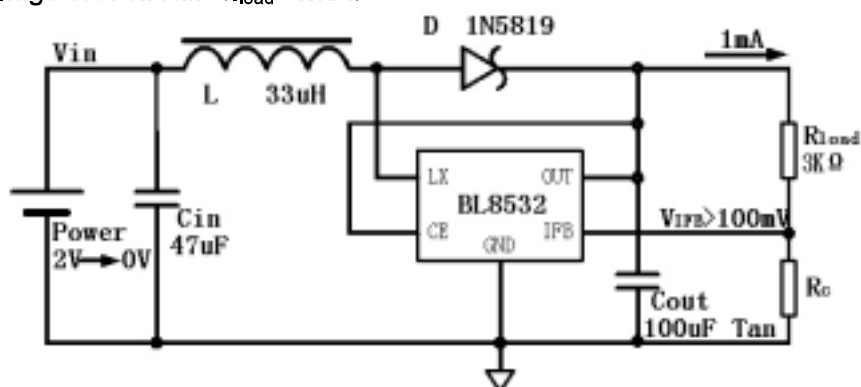
 (2) Start-up voltage test circuit ($I_{load}=1\text{mA}$)

 (3) Hold-on voltage test circuit ($I_{load}=1\text{mA}$)

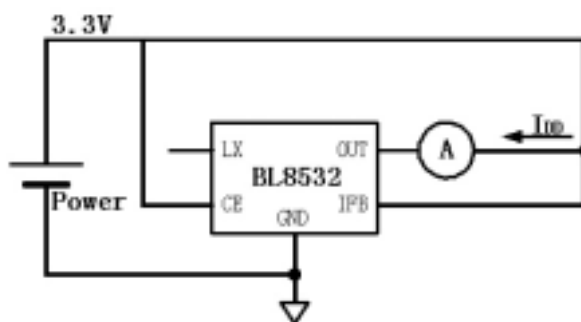
(4) Quiescent current test circuit

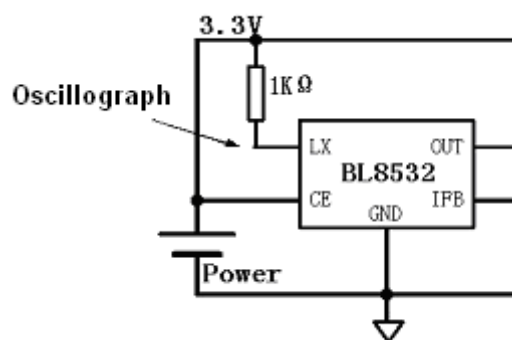

(5) Oscillator frequency and duty cycle test circuit



(6) LX switching current test circuit

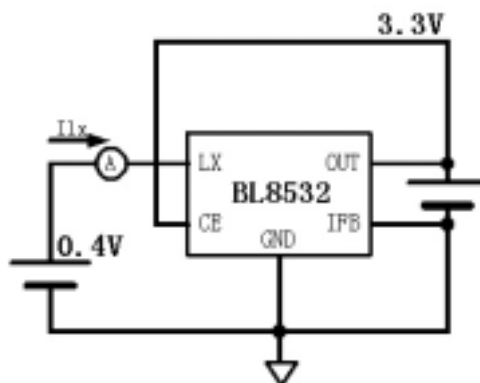

(7) LX leakage current test circuit

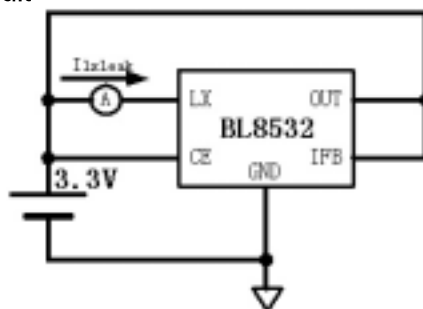

(8) CE “H” voltage test circuit

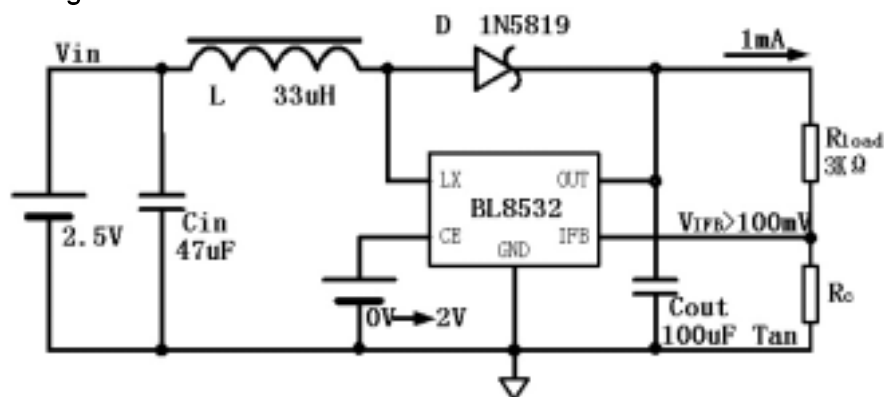

(9) CE “L” voltage test circuit

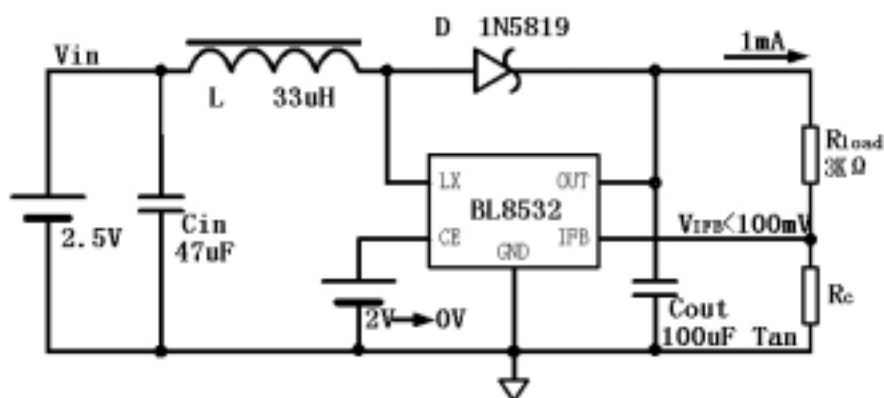

(10) Maximum output voltage (with no load) test circuit

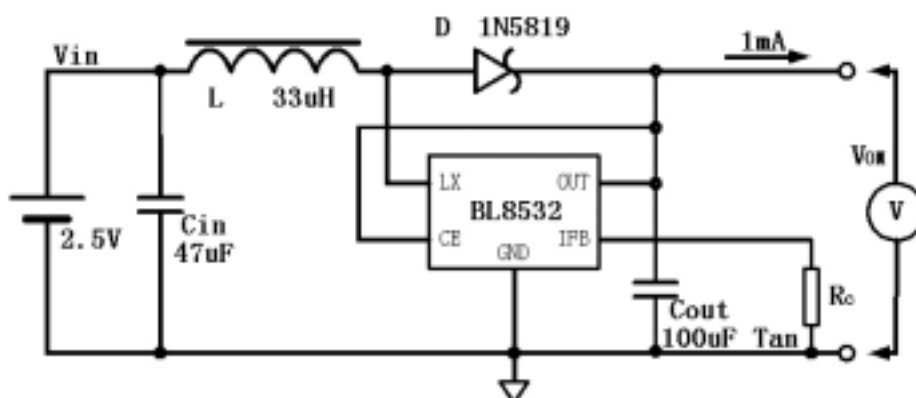

Typical characteristic:

 (Operating conditions: $C_{in}=47\mu F, C_1=22\mu F, C_{out}=100\mu F, L=22\mu H$ $T_{opt}=25^\circ C$ 。 Unless otherwise noted)

1. Output Current VS. Input Voltage

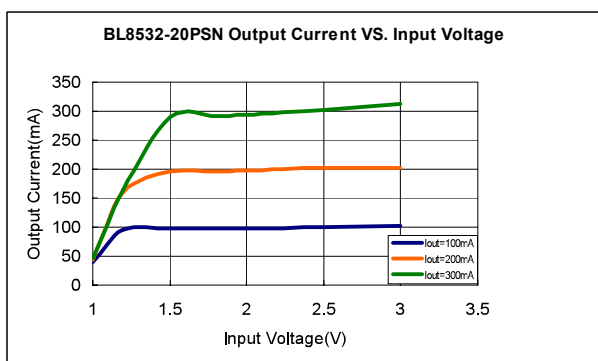

2. Efficiency VS. Input Voltage

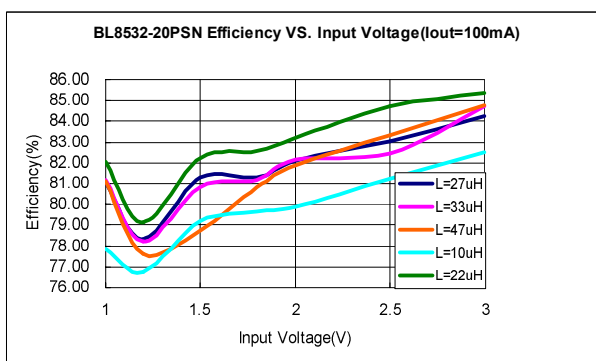

3. Efficiency VS. Input Voltage

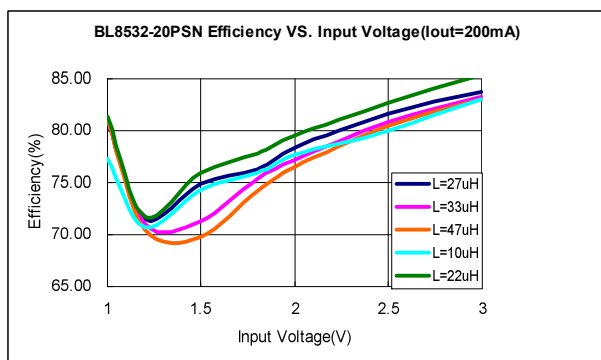

4. Efficiency VS. Input Voltage

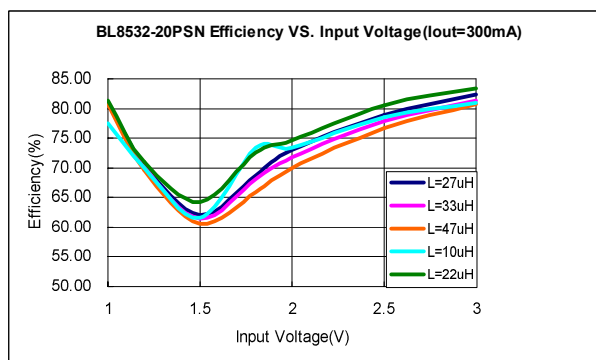

5. Ripple Voltage VS. Input Voltage

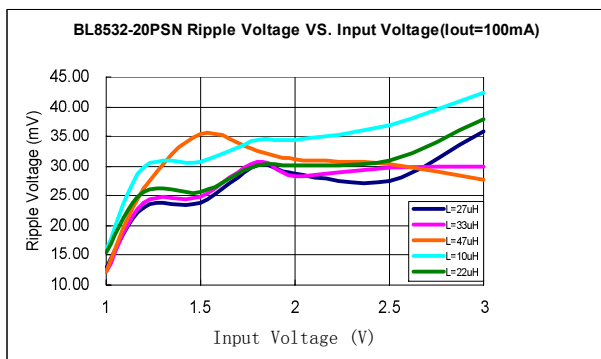

6. Ripple Voltage VS. Input Voltage

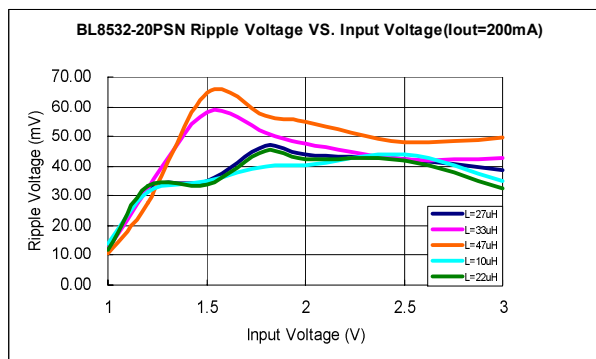

7. Ripple Voltage VS. Input Voltage

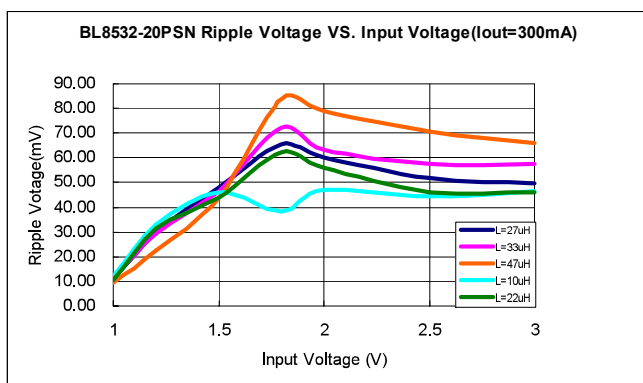

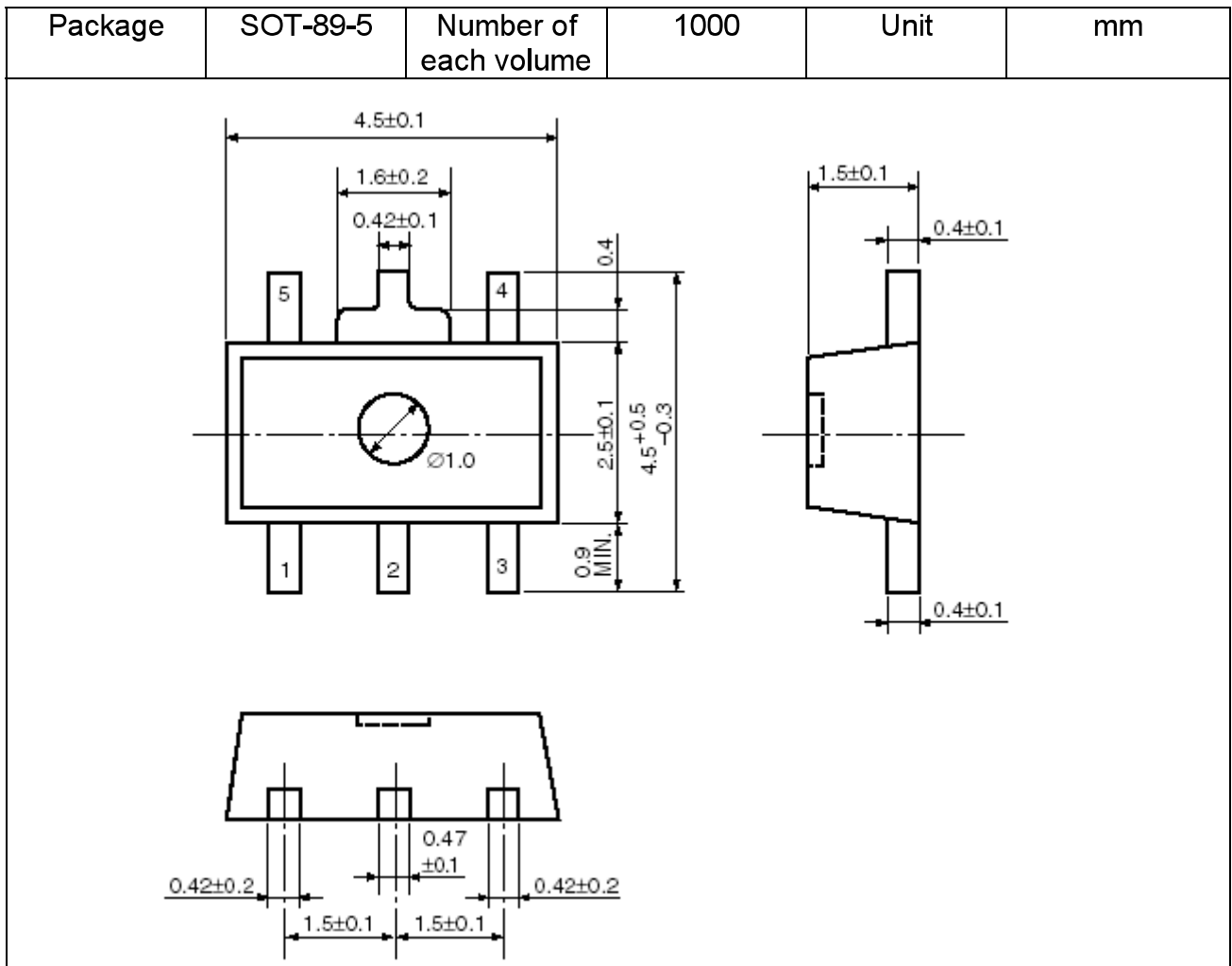
Package description:

Brede size:

Mode (1) is the standard package;
 Mode (2) is customized for client.

