

---

# CYT3000A Specification

## The product description

CYT3000A is a high power factor linear constant current driver on high voltage LED chips, used in LED lighting field. The IC CYT3000A through a unique patented technology, constant current control to realize constant current precision is less than  $\pm 5\%$ , the output current can be regulated by the external REXT resistance. The IC CYT3000A with high power factor and low harmonic distortion.

Simple system structure , the IC CYT3000A has a variety of protection function without transformer and electrolytic capacitor, the IC CYT3000A use few peripheral components, can save the space of electronic components, which can realize mass homework for LED lighting solution.

## Features

- With no transformer and electrolytic capacitors
- Integrated high voltage power supply
- Output current can be adjusted, the maximum of 60mA
- Current deviation  $< \pm 5\%$
- Efficiency:  $> 80\%$
- PF  $> 0.95$
- THD:  $< 20\%$
- With overheating protection function
- Applications without EMI problems
- ESOP8 packaging format

## Application

- T5 / T8 series LED tube
- LED bulb light
- LED downlight
- LED ceiling light

## Pin figure

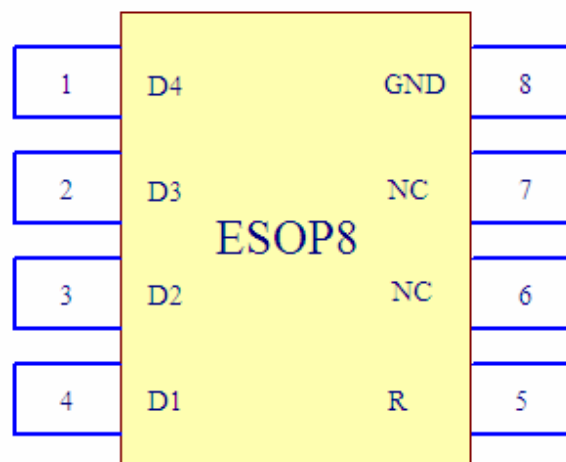

## Model circuit diagram

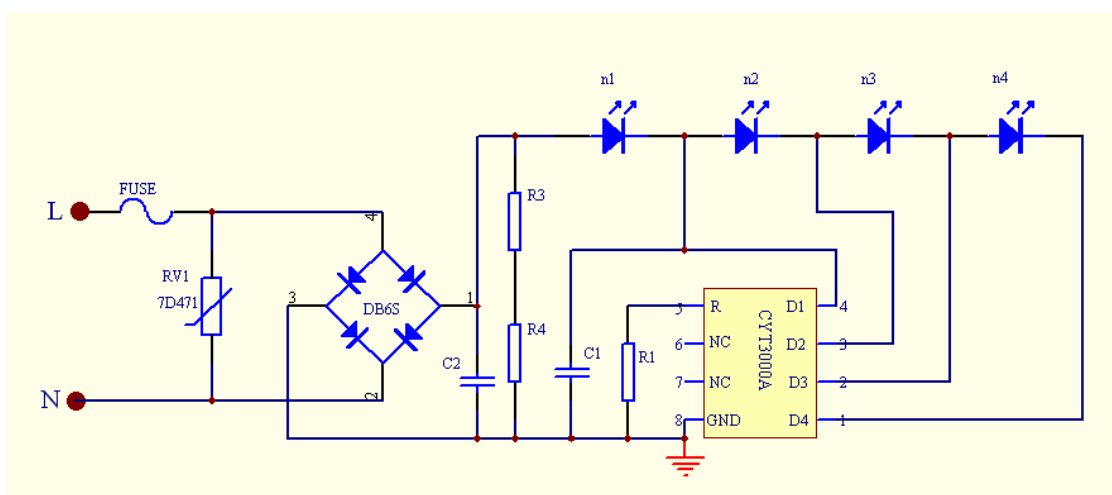

picture 1 3000A Model Application Solutions

## Pin Definition

Pin name	Pin No.	Definition
D4	1	Constant current output port 4
D3	2	Constant current output port 3
D2	3	Constant current output port 2
D1	4	IC power input & Constant current output port 1
R	5	Value of output current set port
NC	6、7	NC
GND	8	GND

## Absolute Maximum Rating

Parameters	Symbol	Range
Working temperature	TOP	-20℃~+120℃
Storage temperature	TSTG	-50℃~+150℃
ESD stress	VESD	>2000V

## Electrical characteristics

Parameters	Symbol	Condition	Min	Typical value	Max	Unit
D1 Input voltage	VD1	----	9			V
Output current	IOUT	----	10		60	mA
REXT port voltage	VREXT	VD1=VD4=10		0.9		V
D1/D2 port pressure	VDS_BV1	ID1=ID2=0	400			V
D3/D4 port pressure	VDS_BV2-4	ID3=ID4=0	250			V
IOUT precision	DIOUT	IOUT=10mA~50mA		±5		%
Current compensation starting point	TSC	-	-	110	-	℃

## Current Settings

CYT3000A is LED constant current drive control circuit, integrated multi-functions module such as LED constant current control module, the OUT port driver module and so on. The IC CYT3000A D1 port minimum input voltage is 6 v ( $I_{OUT} = 20\text{ ma}$ ), can be achieved through external REXT resistance output current from  $10\text{mA} \sim 60\text{mA}$ , built-in LED constant current driver module can make the LED current in high precision and is not affected by environmental temperature. IC CYT3000A can be realized through step by step to open four switch high efficiency, high power factor.

CYT3000A output current adjusted by REXT resistance,  $I_{OUT} = V_{REXT}/R$ , 4 level switch opens output current step by step as follows:

$$ID1=0.55V/R$$

$$ID2=0.70V/R$$

$$ID3=0.85V/R$$

$$ID4=0.90V/R$$

## Application solutions

### ◆ CYT3000A Typical application solutions

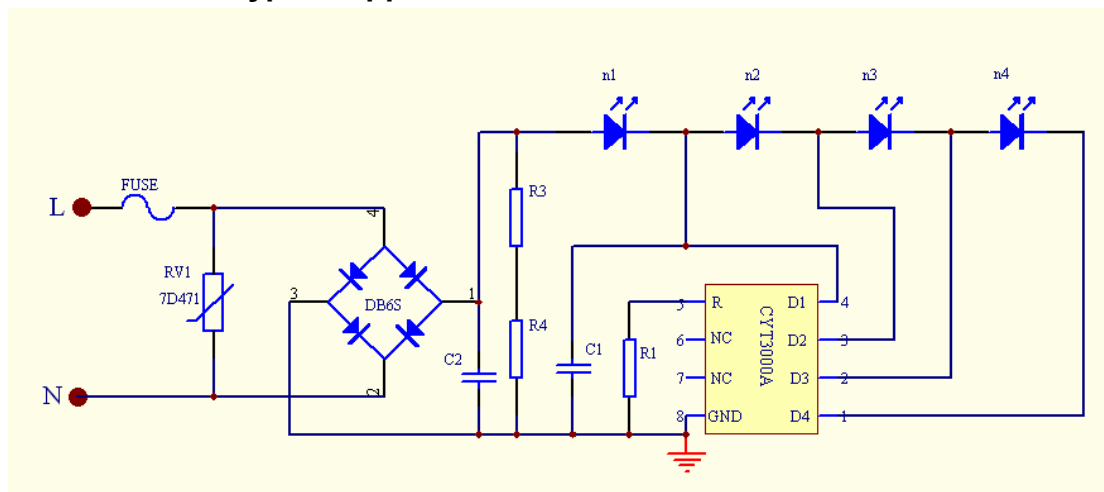

picture 2. 3000A Model Application Solutions

## CYT3000A Parallel scheme

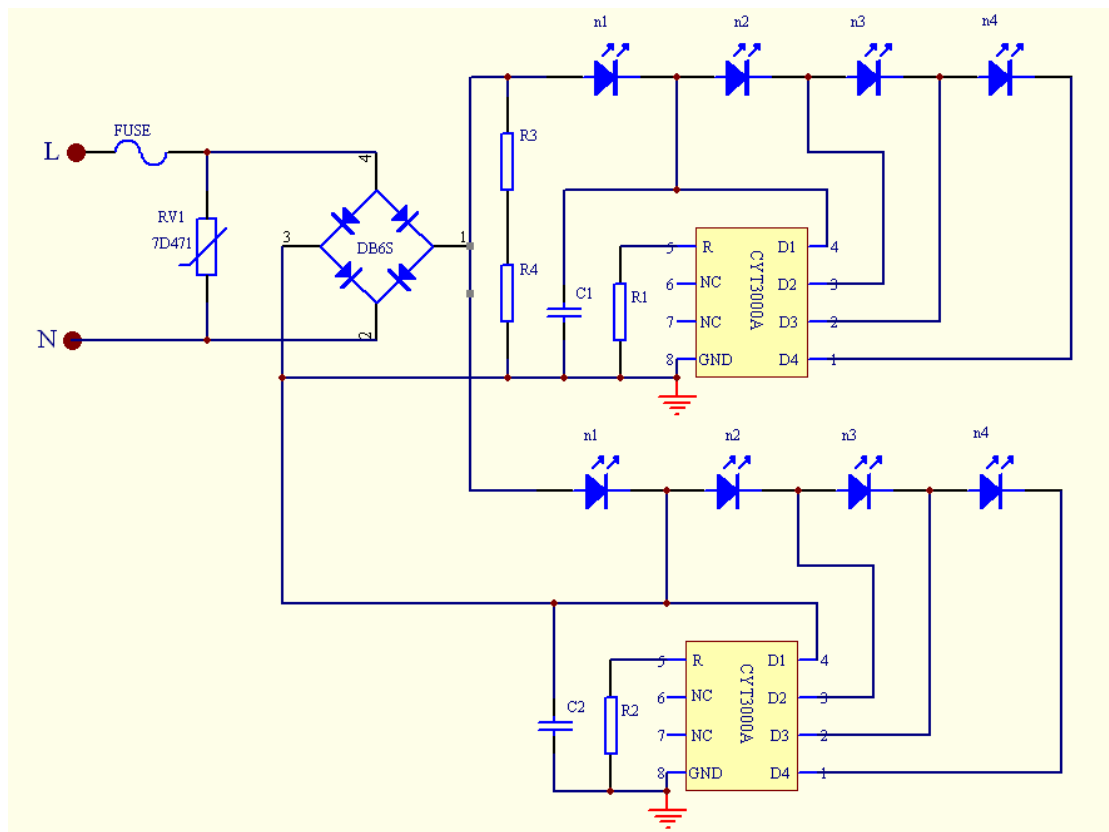

Picture3. CYT3000A Parallel scheme

## ◆ Reference design—PCB design

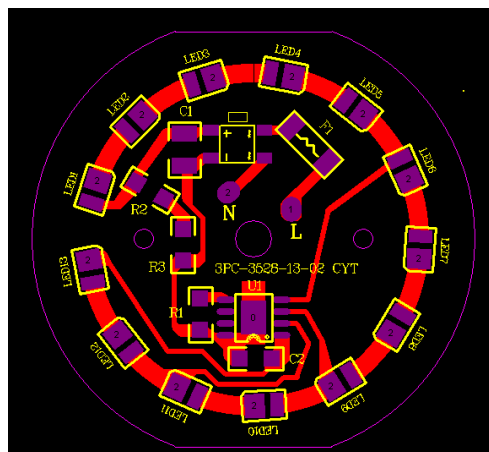

PCB Picture

## Reference design - application circuit diagram

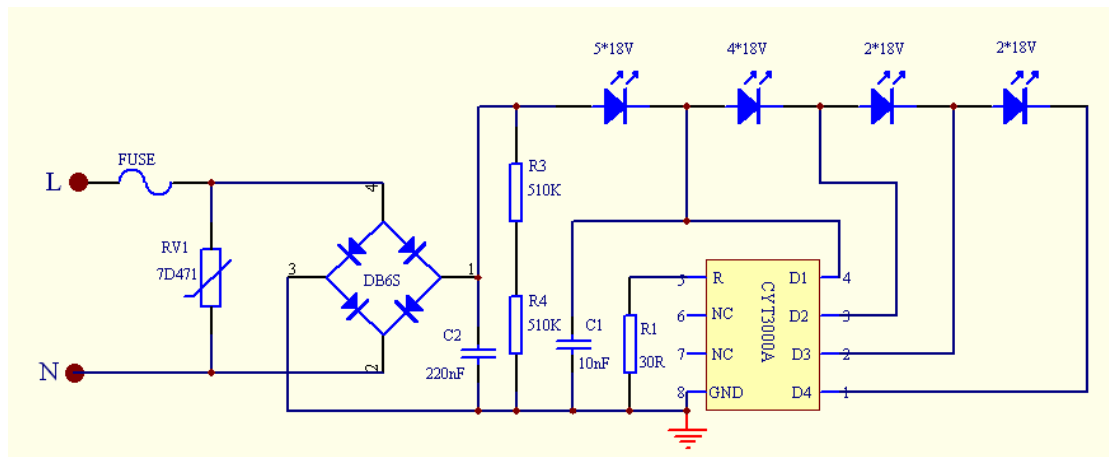

Remark : C2 capacitor is EMI components

### ◆ Reference design - 5W Module BOM

Components	Name	Specifications	Qty
F1	SMD fuse	MF2410F2.000TM, 250V/1A	1
DB1	SMD Rectifier bridge	MB6S, 600V 0.5A MBS	1
U1	Constant current IC	ESOP-8, CYT3000A	1
LED1-LED13	SMD LED	CYT2835-E36C-00, 18V	13
C2	MLCC	1210, 1/3W0.22uF/400V	1
C1	MLCC	1206, 10nF, 1KV	1
R1	SMD Resistor	1206, 1/4W 30R ±1%	1

## Package Type

### ESOP8

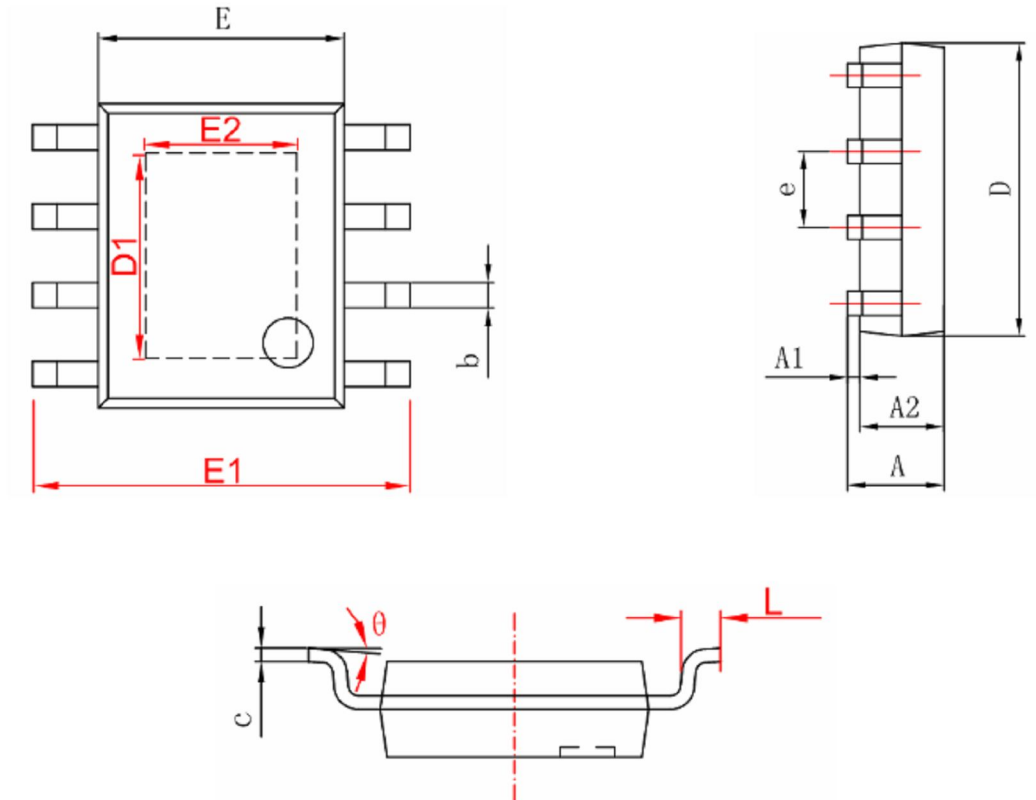

	MILLIMETERS		INCHES	
	MIN	MAX	MIN	MAX
A	1.350	1.750	0.053	0.069
A1	0.050	0.150	0.004	0.010
A2	1.350	1.550	0.053	0.061
b	0.330	0.510	0.013	0.020
c	0.170	0.250	0.006	0.010
D	4.700	5.100	0.185	0.200
D1	3.202	3.402	0.126	0.134
E	3.800	4.000	0.150	0.157
E1	5.800	6.200	0.228	0.244
E2	2.313	2.513	0.091	0.099
e	1.270(BSC)		0.050(BSC)	
L	0.400	1.270	0.016	0.050
$\theta$	0°	8°	0°	8°