

15 ~ 60mA Single/Dual channel LED Driver

Features

- The most easy used linear constant current LED driver
- 15mA~ 60mA, 1 to 2 channel constant current regulator
- No external current setting resistor is needed
- 1.5V ~ 12V wide supply voltage range supports self power structure in lighting application
- Very low dropout voltage
 $I_{PN} \leq 40mA \rightarrow V_{PN} \approx 0.4V$
 $I_{PN} > 40mA \rightarrow V_{PN} \approx 0.6V$
- PWM dimming by V_{DD} pin
- 2uS/2uS current rising/falling time
- -40°C ~ 120°C junction operating temperature
- Cascade-able for higher voltage applications*
 (type 1Axx only)
- Current leak/no leak design for lighting/display application
- Less than 1%/V load (or line) regulation
- Minimized footprint
- Green package

Product Description

NU501 is a simple general purpose current regulation component that can be easily used in various LED lighting applications. With the excellent load/line regulation and minimized chip current skew, NU501 keep LED's current very stable even when power or load fluctuate in a wide range and make light intensity very uniform in large area of LED light source.

Except power supply function, the V_{DD} pin of NU501 is output enable (OE) also, and can be used in digital PWM controlled circuit to achieve more precise current adjusting in gray level applications.

The minimized power supply voltage let NU501 be used as a current regulative diode (CRD) when V_{DD} and V_P pin are tight together. This application makes NU501 very easy to be used. Just like a diode, when this diode is inserted in LED series, the current in circuit is regulated.

In high supply voltage and low LED load voltage applications, two or more single channel NU501 (A type) can be connected in series to share redundant high voltage. With the unique share voltage technology of NUMEN Tech., the extra redundant voltage can be shared by each NU501 by a reasonable mechanism. This special capability let NU501 very suit for the usage of wide range power supply that many liner type LED drivers cannot work.

Applications

Type A – For lighting application

- General LED lighting
- LCD back lighting
- LED torch / flashlight
- RGB lighting

Type B – For display application (No current leak)

- RGB display pixel driver

Package Type

- SOT 23-3 (single channel, type A/B)

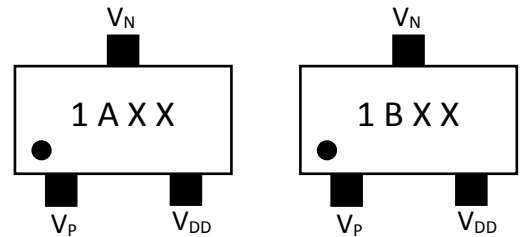

PS: Customized product for special order

- SOT23-5 (dual channel, type A, 2A18 and 2A20 only) – two independent driver in single package.

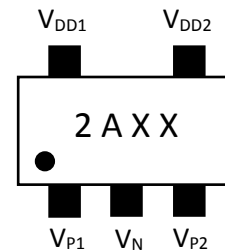

PS: Customized product for special order

- SOT89-3 (single channel, type A, 1A60 only)

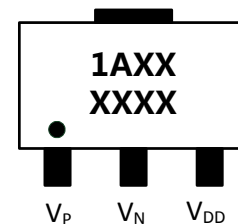

Terminal Description

Pin name	Function
V _{DD}	Power supply
V _P	Current in
V _N	Current out

Ordering Information

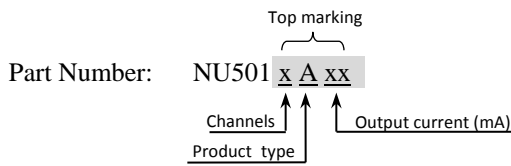

Example: “1A25” is single channel cascade-able NU501, current 25mA.

“1B25” is single channel NU501, current 25mA

“2A20” is dual channel NU501, current 20mA.

PS: Before you issue your P.O., please contact your agent or NUMEN technology to make sure the channel and center current that is available.

Block Diagram per channel and Ideal IV characteristic

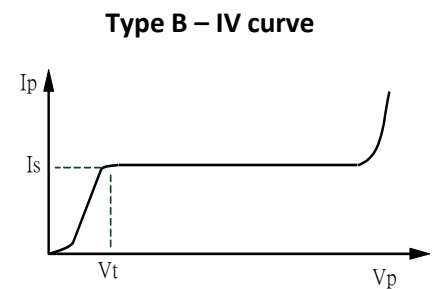
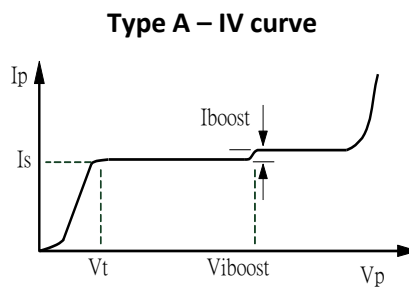
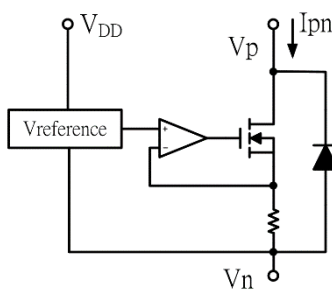

Maximum Ratings (T = 25°C)

Characteristic	Symbol	Rating	Unit
Supply voltage	V _{DD}	0 ~ 16	V
Output voltage	V _P	-0.2 ~ 17	V
Output current	I _{PN}	I _S ** +10%	mA
Power Dissipation (Ta=25°C)	PD	SOT 23	0.4
		SOT 89	0.7
Thermal Resistance (On PCB, Ta=25°C)	R _{TH(j-a)}	SOT 23	300
		SOT 89	180
Operating temperature	T _{OPR}	-40~+85	°C
Storage temperature	T _{STG}	-55~+150	°C

Electrical Characteristics and Recommended Operating Conditions

Characteristic	Symbol	Condition	Min.	Typ.	Max.	Unit	
Supply voltage	V_{DD}	Room Temp. $V_{PN} \geq 1V$	$I_S \leq 25mA$	1.5	-	12	V
			$I_S \leq 40mA$	2	-	12	
			$I_S > 40mA$	2.5	-	12	
Supply voltage rising and falling speed *1	V_{DDspd}	$V_{DD} \leq 5V$	0.05	-	-	uS	
		$V_{DD} > 5V$	5	-	-		
Supply current	I_{DD}	-	100	150	250	uA	
Minimum dropout voltage	V_{PNmin}	$V_{DD} \geq 3.8V$	0.4	-	0.6	V	
Maximum output voltage	V_{PNmax}	$I_{PN} = I_S$	-	-	$0.25 / I_{PN}$	V	
Output breakdown voltage	V_{PNBD}	$I_{PN} = 0, V_{DD} = 0V$	-	-	17	V	
Output current	I_S^{*2}	Spec.	15	-	60	mA	
Leakage	$I_{Leakage}$	$0V < V_{DD} < 0.4V,$ $V_P = 10V$	Type A	1	-	5	uA
			Type B	0	-	0.5	uA
Line regulation	$\%/V_{DD}$	$12V > V_{DD} > 1.6V$	-	-	± 1	$\%/V$	
Load regulation	$\%/V_P$	$8V > V_P > 1.6V$	-	-	± 1	$\%/V$	
Thermal regulation	$\%/10^\circ C$	$V_{DD} = V_P = 2V$	-	-	± 0.5	$\%/10^\circ C$	
Threshold voltage (Type A only)	V_{iboot}	$I_P = I_S * 1.1$	11	12	13	V	
Current boost (Type A only)	I_{boost}	$V_P = V_{iboot}$	7	10	13	$\% * I_S$	
Power Dissipation	P_D	Room Temp.		0.25		W	
Chip current skew	I_{skew}	$V_{DD}=3.8V,$ $V_P = 0.8V$	$I_{PN} \leq 40mA$	-	-	5	%
		$V_{DD}=3V,$ $V_P \leq 8V$	$I_{PN} > 40mA$	-	6 $V_P=2.5V$	12 $V_P=8V$	

*1 For the stable reason, the rising and falling speed of supply voltage (V_{DD}) on NU501 should be slower when higher V_{DD} than 5V is adopted. Fast and high V_{DD} transition will bring the timing of output current instable. Please refer to typical application circuit in this specification for proper using.

*2 I_S is output saturation current.

Switching Characteristics (T = 25°C)

Characteristic	Symbol	Condition	Min.	Typ.	Max.	Unit
Propagation Delay Time V_{DD} from "L" to "H"	t_{pLH}	$V_P=1V, V_{DD} = 0V \rightarrow 3V$	-	1	-	uS
Output current rising time	t_{Rise}	$V_P=1V, V_{DD} = 0V \rightarrow 3V$	-	1.5	5	uS
Propagation Delay Time V_{DD} from "H" to "L"	t_{pHL}	$V_P=1V, V_{DD} = 3V \rightarrow 0V$	-	1	-	uS
Output current falling time	t_{Fall}	$V_P=1V, V_{DD} = 3V \rightarrow 0V$	-	1.5	5	uS

Test Circuit

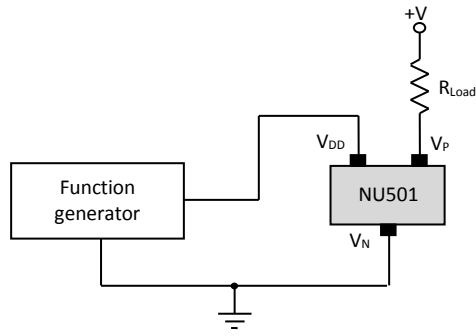

Timing Waveform

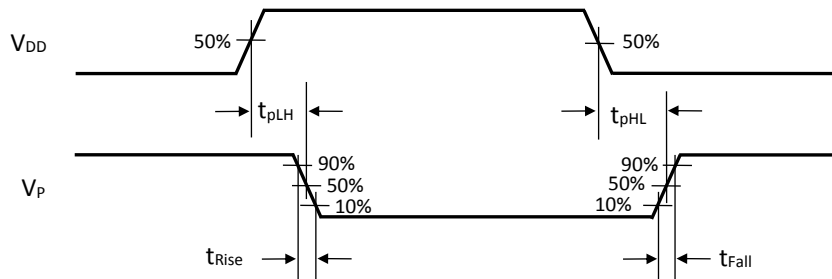

I/V curve

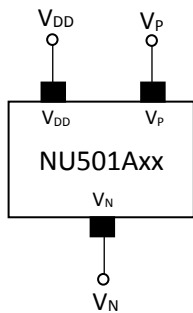

Load regulation characteristic (A type)

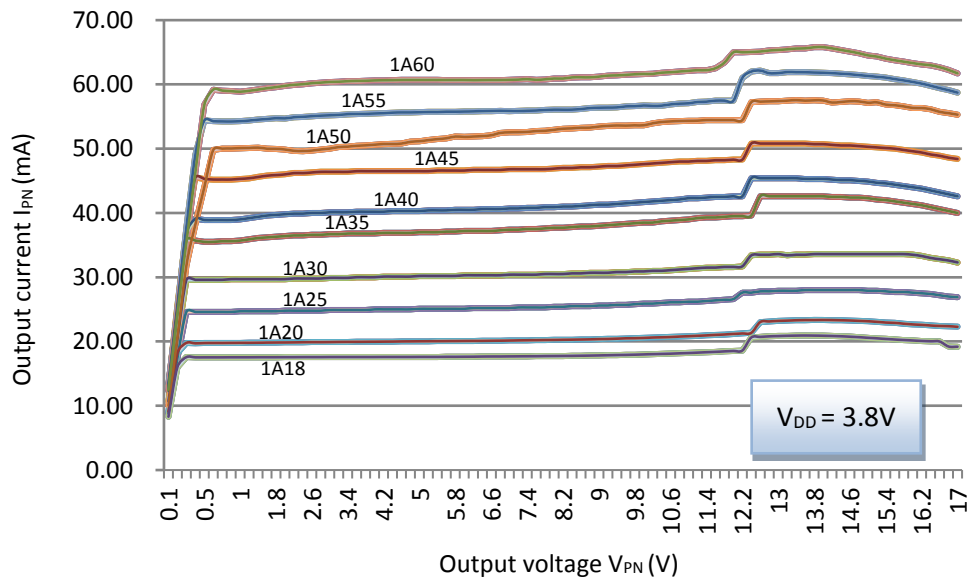

Load regulation characteristic (B type)

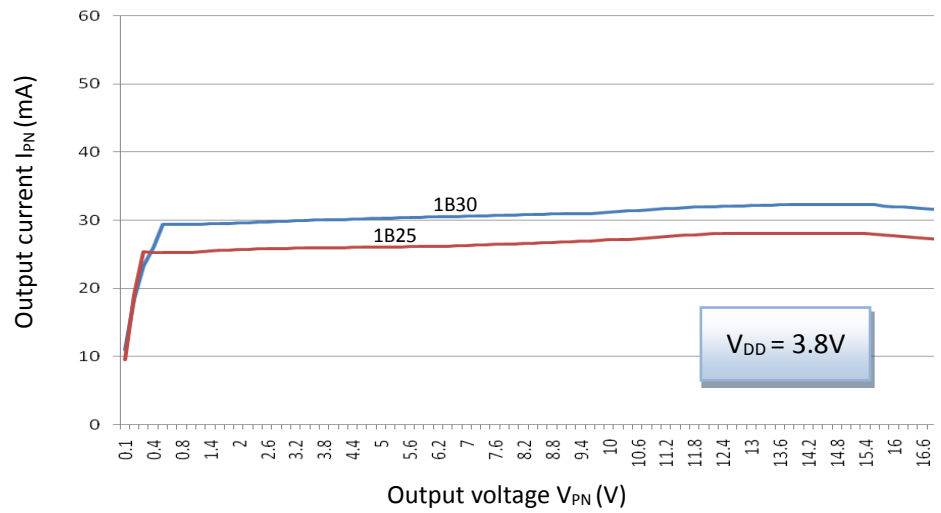
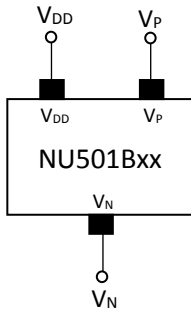

Line regulation characteristic

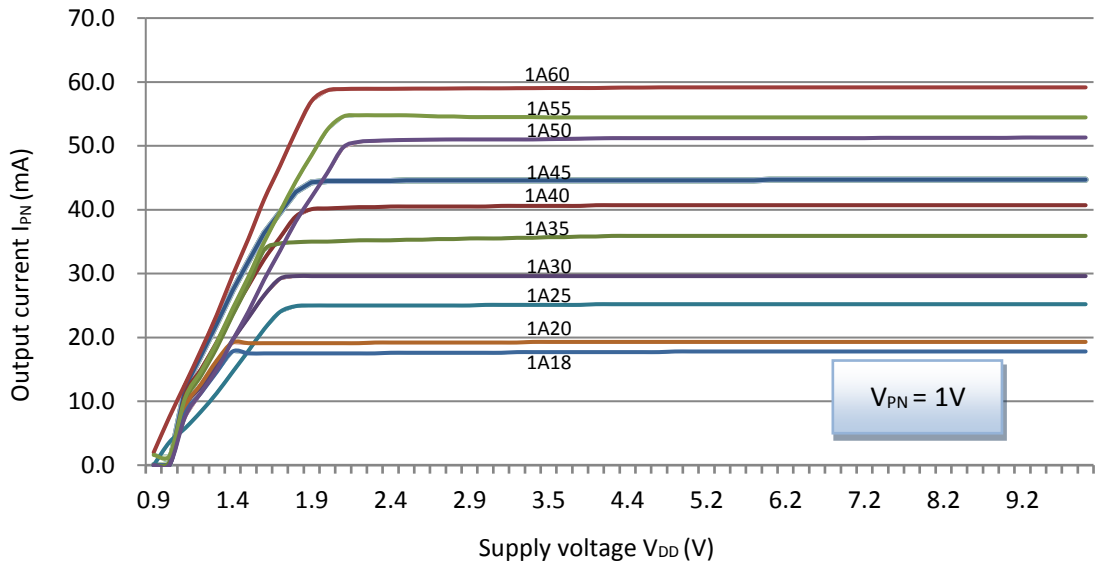

I_{DD} Consumption

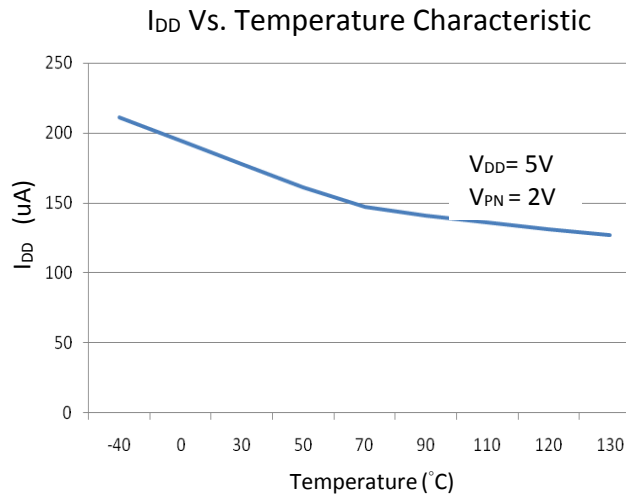
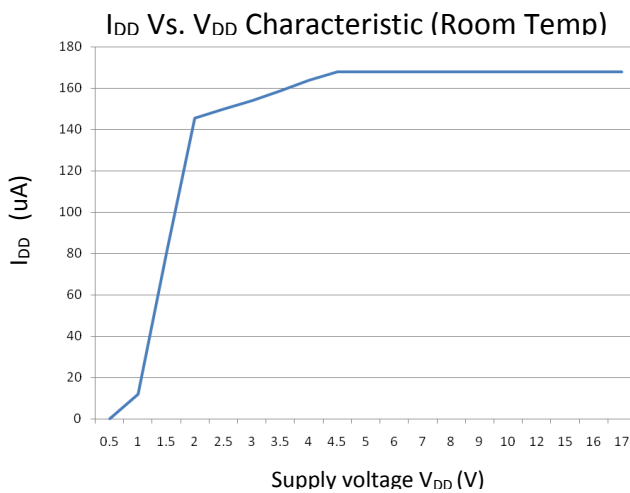

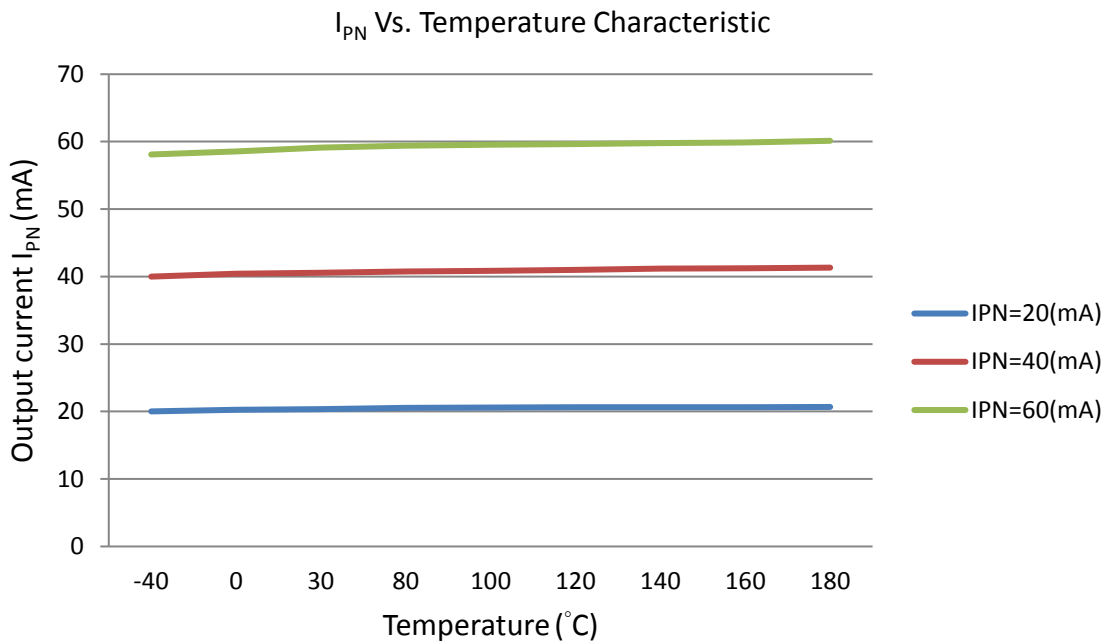
I_{PN}/Temperature Curve**Application design consideration**

NU501 is a linear constant current driver. While this device is designed in lighting system, the heat generation should be considered. Generally, the higher current designed in system, the higher power will suffer by this device. To reduce the power consuming by NU501 and to increase the whole system efficiency, the drop voltage across NU501 should be minimized. The following design note can reduce the heat generation from NU501 in the condition of keeping the required output constant current and the needed supply voltage (normal operation condition).

1. Drop the power supply voltage as low as possible in the normal operation condition.
2. Get the LEDs in current loop as many as possible in the normal operation condition.
3. Get a voltage sharing resistor in series in current loop.
4. If system power is greater than 24W, it suggests to connect a small SMD type capacitor (1nF~100nF) between V_{DD} and V_N pin. That will greatly improve the stability of system.

Application Circuits

- 5V PWM indicator application

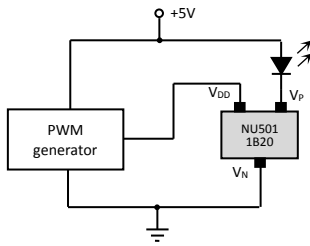

- 24V PWM lighting with dimming application

With the special designed character of leak, the A type NU501 can be used in dimming application even when system power is higher than the maximum V_p voltage.

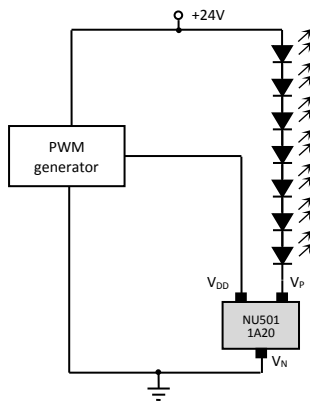

- 12V lighting application

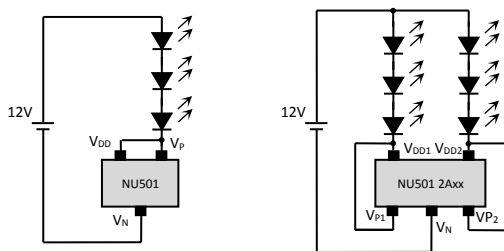

- High voltage drop application

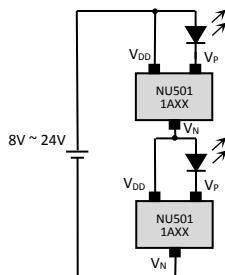

- Parallel application

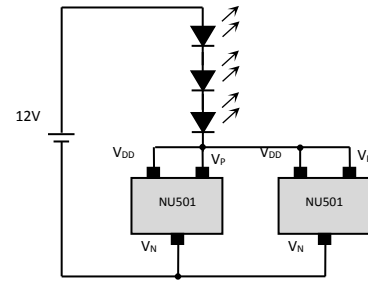

- RGB display pixel application

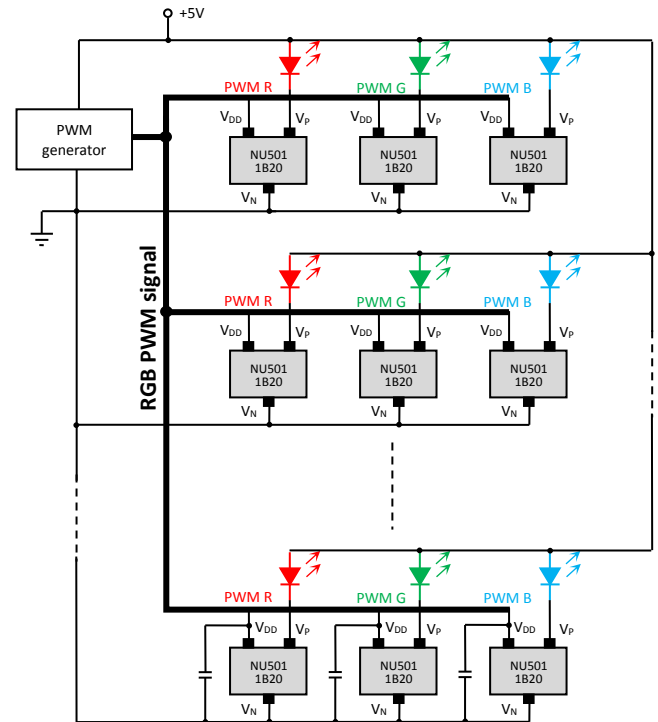

● 36V light tube application

LED $V_F = 2.9V \sim 3.1V$

$V_{LED} = 35.5V \sim 40V$

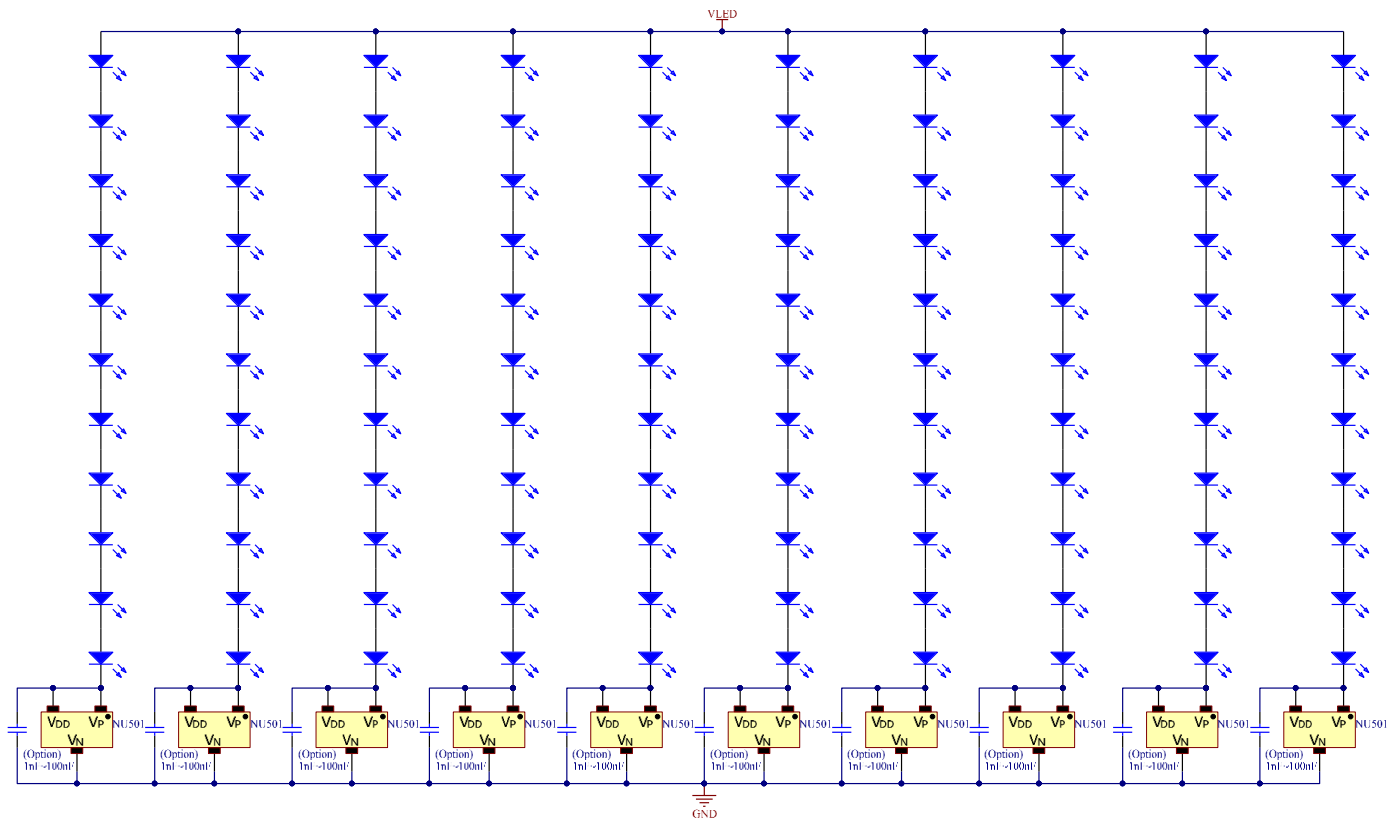

In application of V_{DD} pin short to V_P pin, at least 1.6V drop voltage on NU501 is required for constant output current regulation.

● Wide area lighting with PWM dimming function application

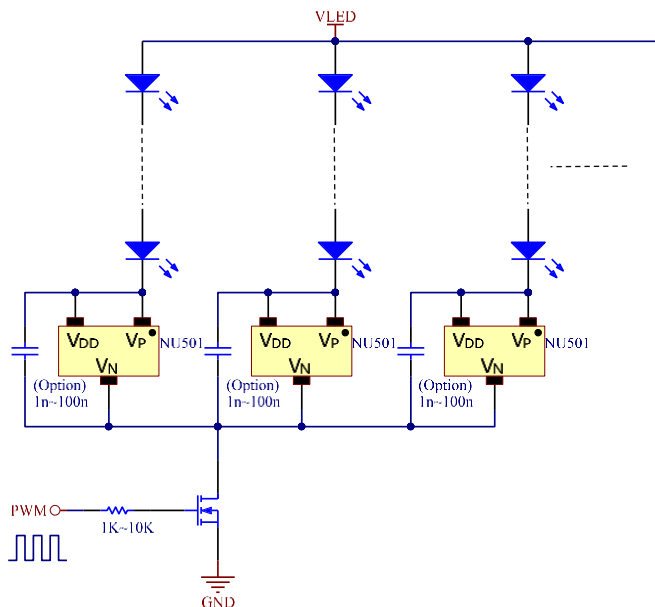

Note: Generally, The capacitance of V_{DD} capacitor when self-power structure is used is about the same as LED typical current. For example, if the typical current of LED is 20mA, the capacitance is about 20nF. The capacitance can be adjusted according to the requirement of real applications.

Package Dimensions

- SOT23-3

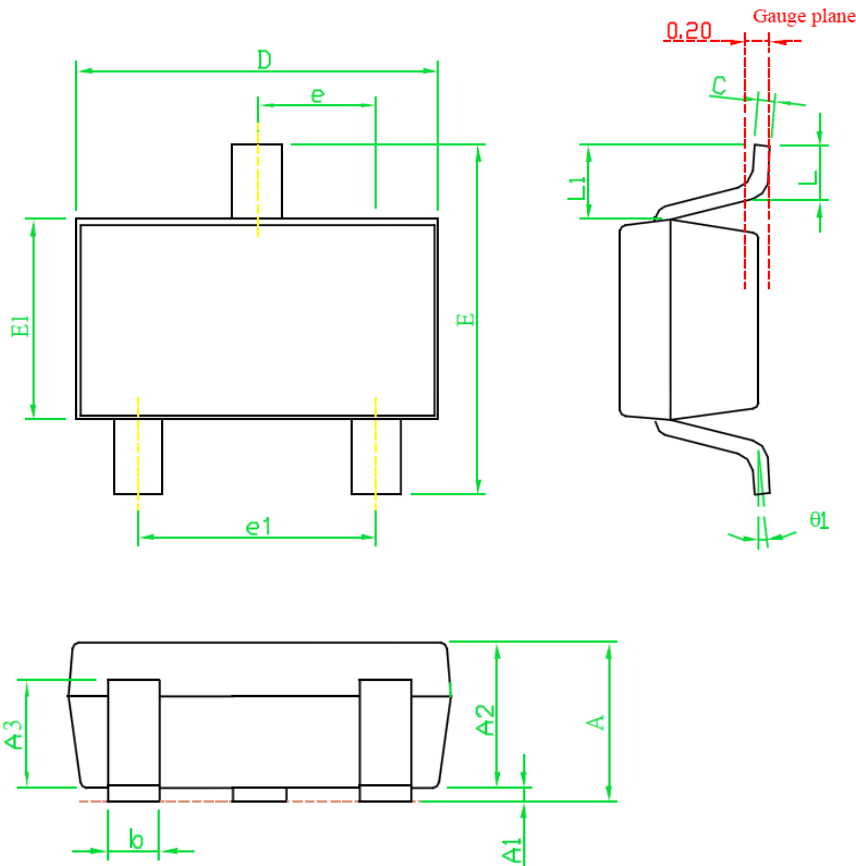

SYMBOLS	DIMENSIONS IN MILLIMETERS		
	MIN	NOM	MAX
A	1.00	1.10	1.40
A1	0.00	----	0.10
A2	1.00	1.10	1.30
A3	0.70	0.80	0.90
b	0.35	0.40	0.50
C	0.10	0.15	0.25
D	2.70	2.90	3.10
E1	1.40	1.60	1.80
e	----	0.95(TYP)	----
e1	----	1.90(TYP)	----
E	2.60	2.80	3.00
L	0.37	----	----
theta1	1°	5°	9°
L1	0.5	0.6	0.7

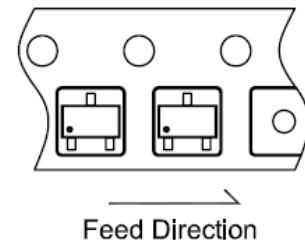

Taping Specification

PACKAGE	Q'TY/REEL
SOT23-3	3,000 ea
SOT23-5	3,000 ea
SOP89	1,000 ea

- SOT23-5

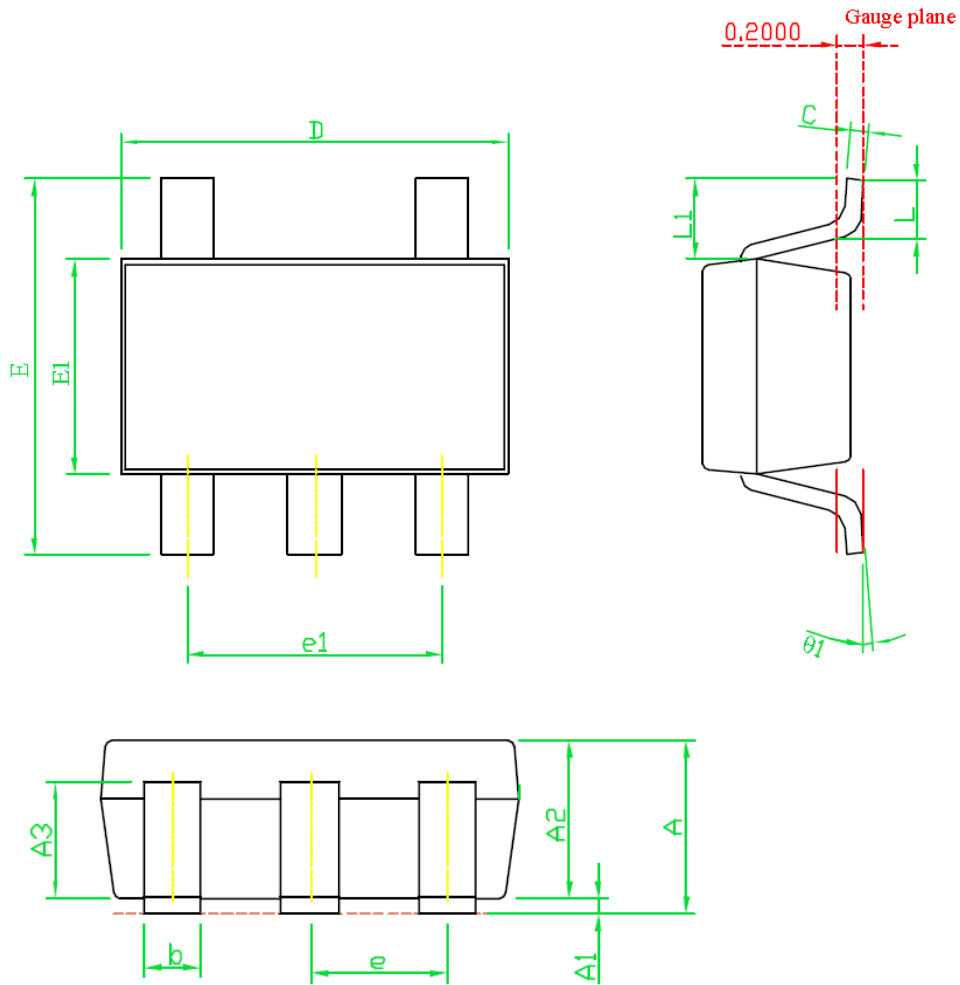

SYMBOLS	DIMENSIONS IN MILLIMETERS		
	MIN	NOM	MAX
A	1.00	1.10	1.40
A1	0.00	---	0.10
A2	1.00	1.10	1.30
A3	0.70	0.80	0.90
b	0.35	0.40	0.50
C	0.10	0.15	0.25
D	2.70	2.90	3.10
E1	1.50	1.60	1.80
e1	---	1.90(TYP)	---
E	2.60	2.80	3.00
L	0.37	---	---
theta1	1°	5°	9°
e	---	0.95(TYP)	---
L1	0.5	0.6	0.7

- SOT89

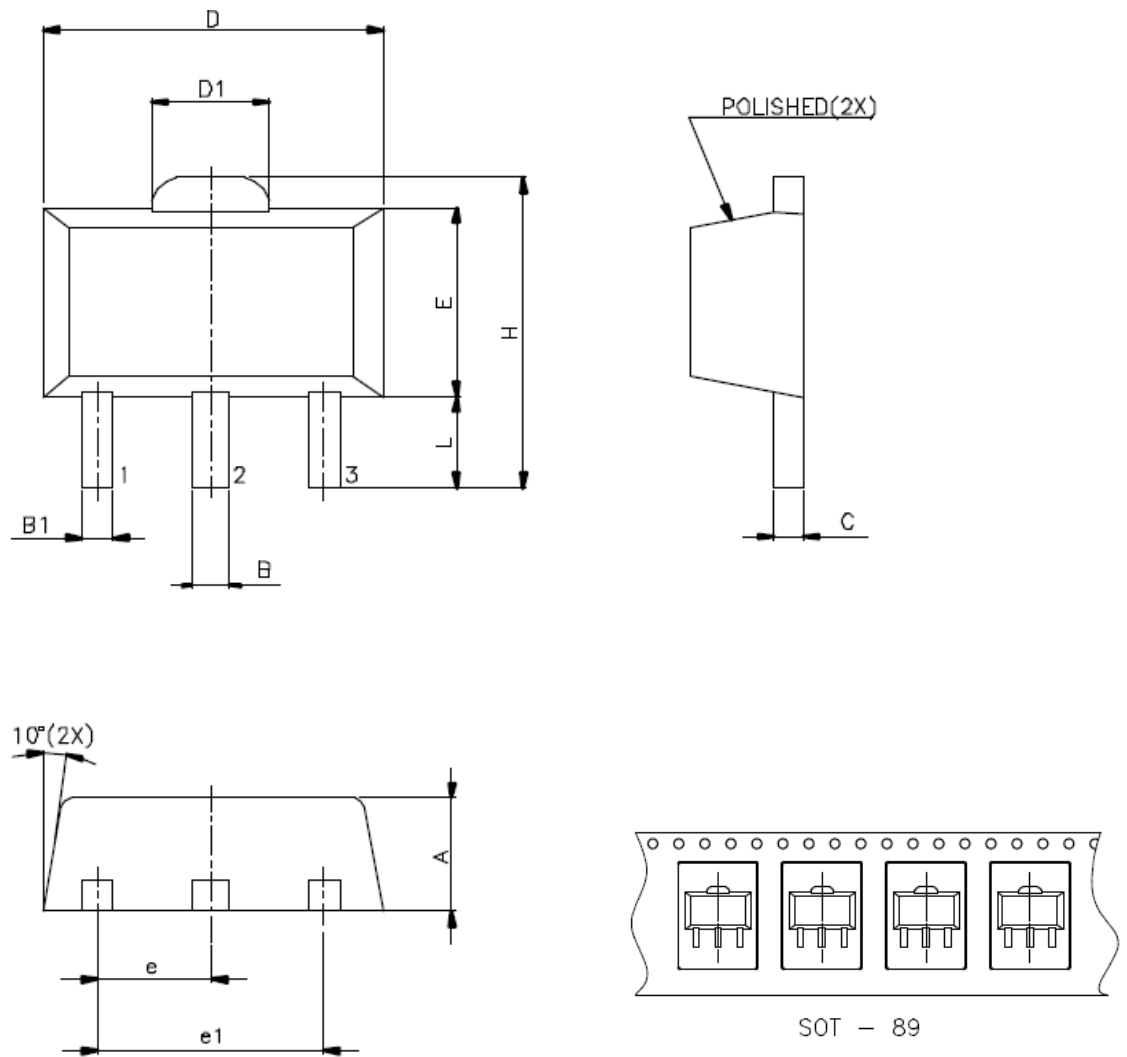

SYMBOLS	MIN.	MAX.
A	1.40	1.60
B	0.44	0.56
B1	0.36	0.48
C	0.35	0.44
D	4.40	4.60
D1	1.35	1.83
E	2.29	2.60
H	3.94	4.25
e	1.50 BSC	
e1	3.00 BSC	
L	0.89	1.2

UNIT : mm

Restrictions on product use

- NUMEN Tech. reserves the right to update these specifications in the future.
- The information contained herein is subject to change without notice.
- NUMEN Technology will continually working to improve the quality and reliability of its products. Nevertheless, semiconductor device in general can malfunction or fail due to their inherent electrical sensitivity and vulnerability to physical stress. It is the responsibility of the buyer, when utilizing NUMEN products, to comply with the standards of safety in making a safe design for the entire system, and to avoid situations in which a malfunction or failure of such NUMEN products could cause loss of human life, bodily injury or damage to property. In developing your designs, please ensure that NUMEN products are used within specified operating ranges as set forth in the most recent NUMEN products specifications.
- The NUMEN products listed in this document are intended for usage in general electronics applications (lighting system, personal equipment, office equipment, measuring equipment, industrial robotics, domestic appliances, etc.). These NUMEN products are neither intended nor warranted for usage in equipment that requires extraordinarily high quality and/or reliability or a malfunction or failure of which may cause loss of human life or bodily injury (“Unintended Usage”). Unintended Usage include atomic energy control instruments, airplane or spaceship instruments, transportation instruments, traffic signal instruments, combustion control instruments, medical instruments, all types of safety devices, etc.. Unintended Usage of NUMEN products listed in this document shall be made at the customer’s own risk.