

DESCRIPTION

PT6964 is an LED Controller driven on a 1/5 to 1/8 duty factor. 10 segment output lines, 4 grid output lines, 3 segment/ grid output lines, one display memory, control circuit, key scan circuit are all incorporated into a single chip to build a highly reliable peripheral device for a single chip microcomputer. Serial data is fed to PT6964 via a three-line serial interface. Housed in a 28 pins SOP Package, PT6964 pin assignments and application circuit are optimized for easy PCB Layout and cost saving advantages.

FEATURES

- CMOS technology
- Low power consumption
- Multiple display modes (10 segments, 7 grids to 13 segments, 4 grids)
- Key scanning (10 x 2 Matrix)
- 8-step dimming circuitry
- Serial interface for clock, data input, data output, strobe pins
- Available in 28 pins, SOP

APPLICATIONS

- Micro-computer peripheral device
- VCR set
- Combo set

BLOCK DIAGRAM

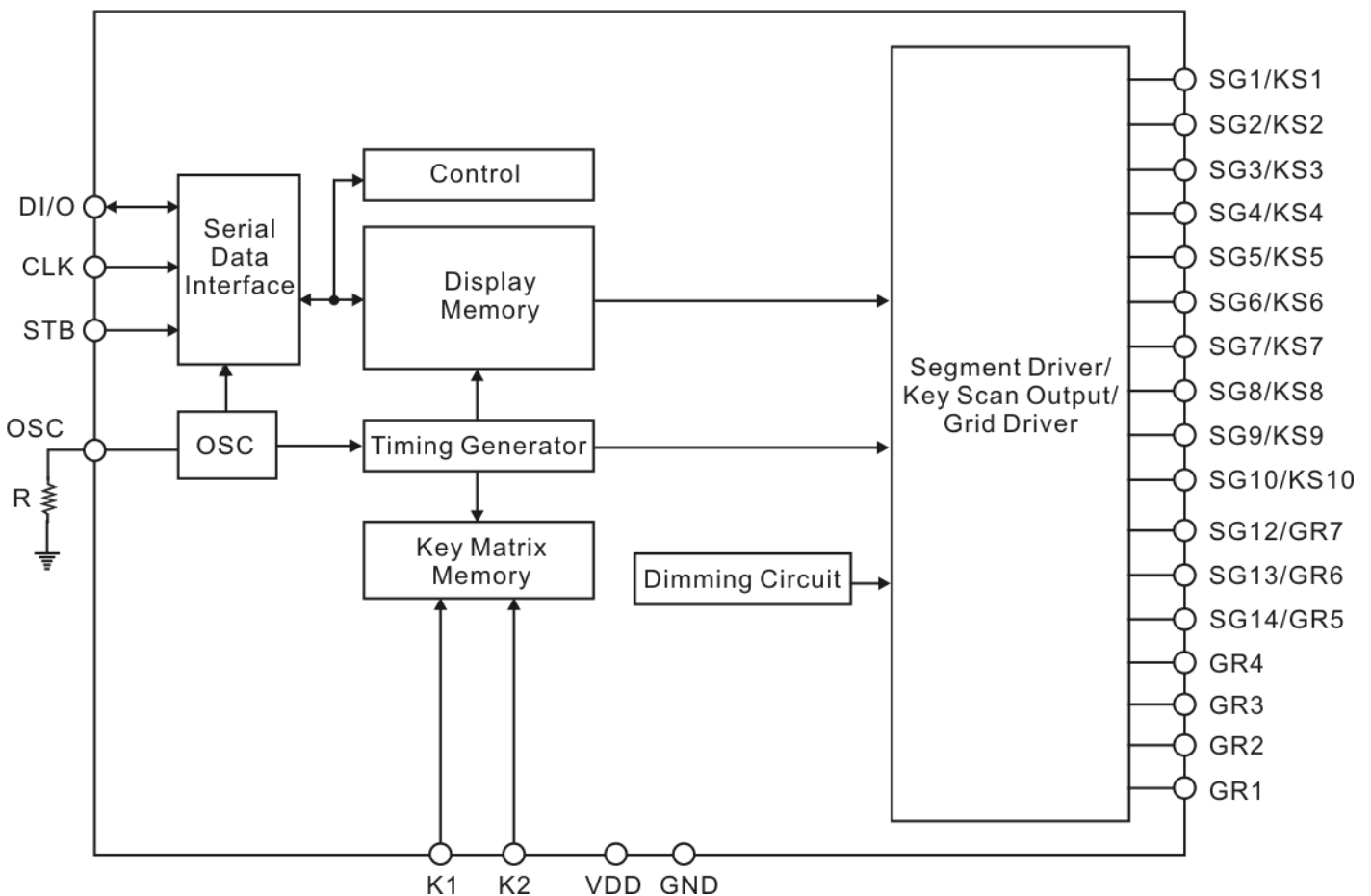

APPLICATION CIRCUIT

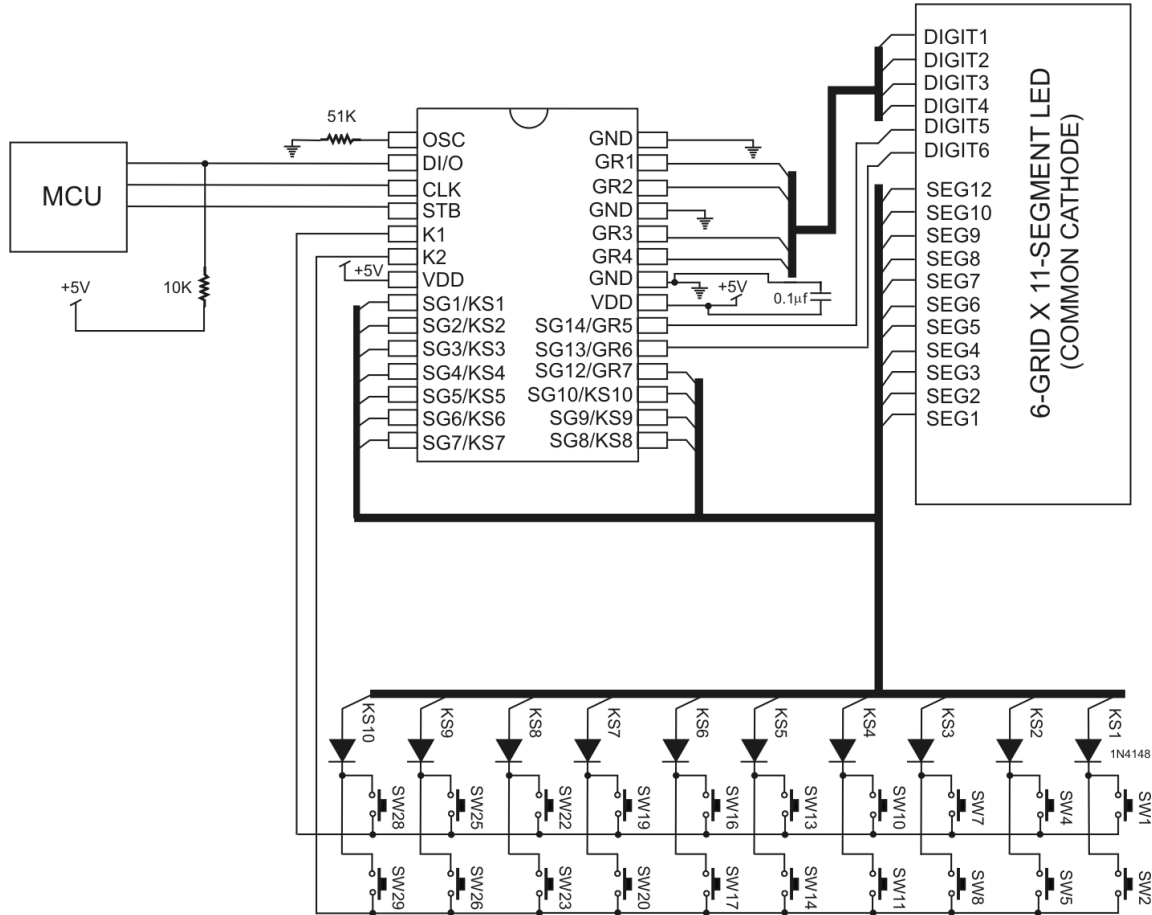

Notes:

1. The capacitor (0.1µF) connected between the GND and the VDD pins must be located as close as possible to the PT6964 chip.
2. The PT6964 power supply is separate from the application system power supply.

COMMON CATHODE TYPE LED PANEL

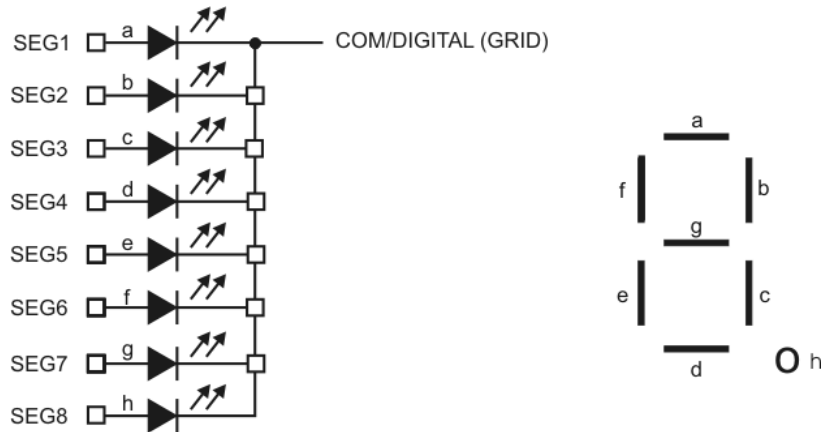

ORDER INFORMATION

Valid Part Number	Package Type	Top Code
PT6964-S	28 Pins, SOP, 300mil	PT6964-S

PIN DESCRIPTION

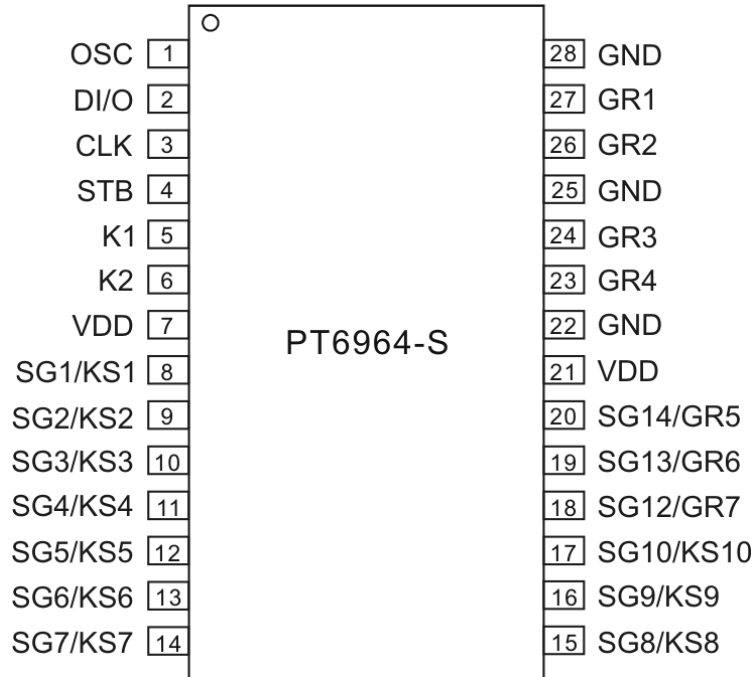

PIN DESCRIPTION

Pin Name	I/O	Description	Pin No.
OSC	I	Oscillator Input Pin A resistor is connected to this pin to determine the oscillation frequency	1
DI/O	I/O	Data Input Pin This pin inputs serial data at the rising edge of the shift clock (starting from the lower bit) Data Output Pin (N-Channel, Open-Drain)	2
CLK	I	Clock Input Pin This pin reads serial data at the rising edge and outputs data at the falling edge.	3
STB	I	Serial Interface Strobe Pin The data input after the STB has fallen is processed as a command. When this pin is HIGH", CLK is ignored.	4
K1 ~ K2	I	Key Data Input Pins The data sent to these pins are latched at the end of the display cycle. (Internal Pull-Low Resistor)	5, 6
VDD	-	Power Supply	7, 21
SG1/KS1 ~ SG10/KS10	O	Segment Output Pins (p-channel, open drain) Also acts as the Key Source	8 ~ 17
SG12/GR7 ~ SG14/GR5	O	Segment / Grid Output Pins	18 ~ 20
GND	-	Ground Pin	22, 25, 28
GR4 ~ GR1	O	Grid Output Pins	23, 24, 26, 27,

INPUT/OUTPUT CONFIGURATIONS

The schematic diagrams of the input and output circuits of the logic section are shown below.

INPUT PINS: CLK, STB

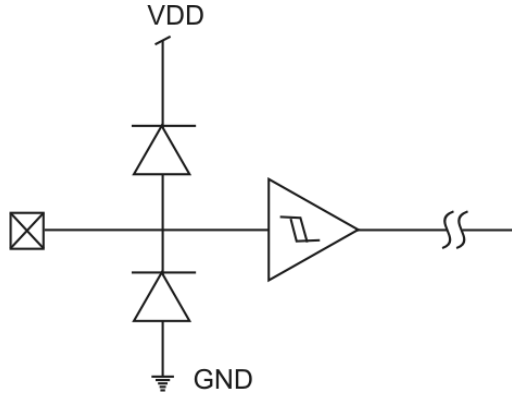

INPUT PINS: K1 TO K2

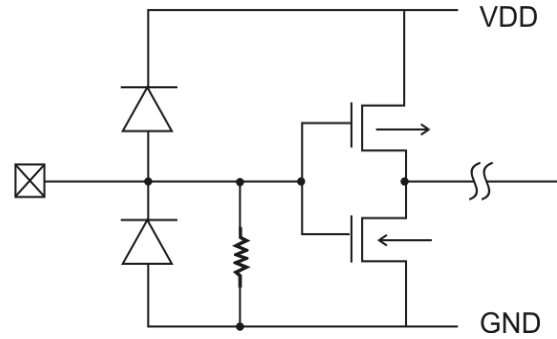

OUTPUT PINS: GR1 TO GR4

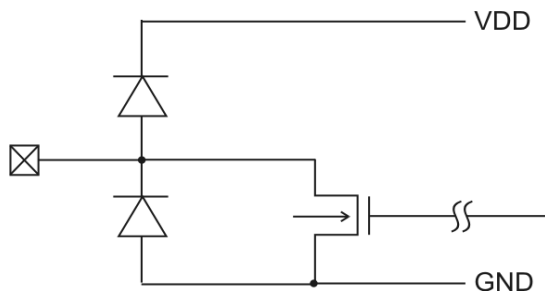

OUTPUT PINS: SG1/KS1 TO SG10/KS10

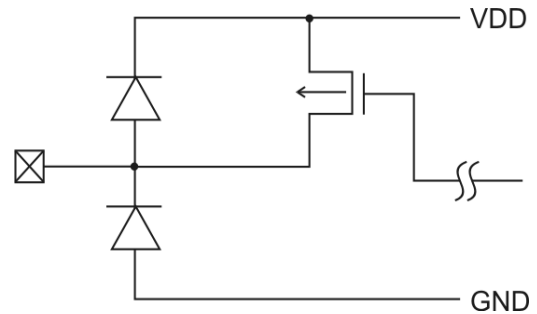

OUTPUT PINS: SG14/GR5, SG13/GR6 AND SG12/GR7

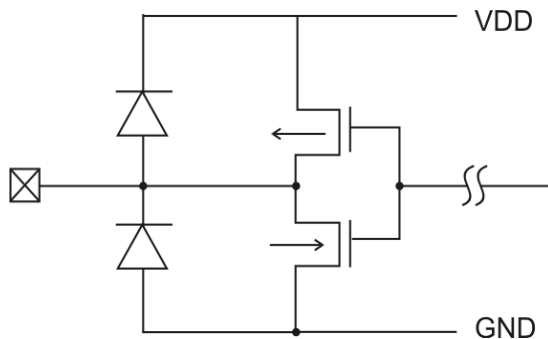

INPUT PIN & OUTPUT PIN: DI/O

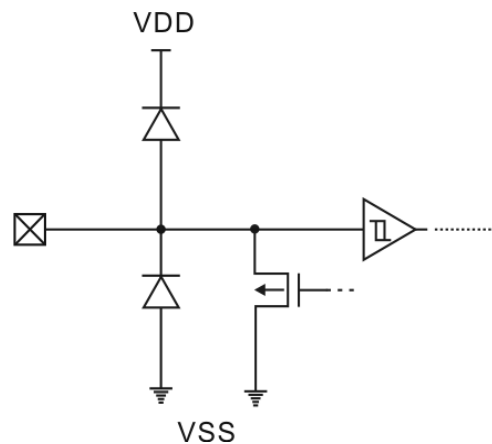

FUNCTION DESCRIPTION

COMMANDS

A command is the first byte (b0 to b7) inputted to PT6964 via the DI/O Pin after STB Pin has changed from HIGH to LOW State. If for some reason the STB Pin is set to HIGH while data or commands are being transmitted, the serial communication is initialized, and the data/commands being transmitted are considered invalid.

COMMANDS 1: DISPLAY MODE SETTING COMMANDS

PT6964 provides 4 display mode settings as shown in the diagram below: As stated earlier a command is the first one byte (b0 to b7) transmitted to PT6964 via the DI/O Pin when STB is LOW. However, for these commands, the bit 3 to bit 6 (b2 to b5) are ignored, bit 7 & bit 8 (b6 to b7) are given a value of 0.

The Display Mode Setting Commands determine the number of segments and grids to be used (10 to 13 segments, 7 to 4 grids). A display command ON must be executed in order to resume display. If the same mode setting is selected, no command execution is take place, therefore, nothing happens.

When Power is turned ON, the 7-grid, 10-segment modes is selected.

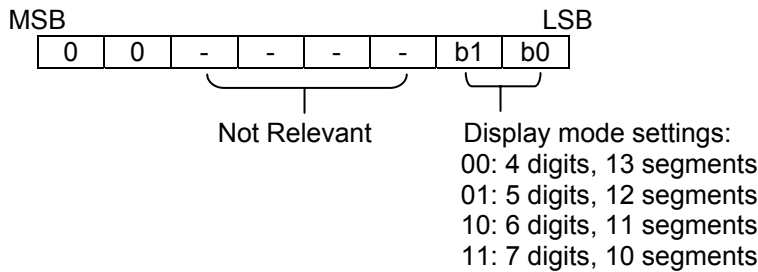

COMMANDS 2: DATA SETTING COMMANDS

The Data Setting Commands executes the Data Write or Data Read Modes for PT6964. The data Setting Command, the bits 5 and 6 (b4, b5) are ignored, bit 7 (b6) is given the value of 1 while bit 8 (b7) is given the value of 0. Please refer to the diagram below.

When power is turned ON, bit 4 to bit 1 (b3 to b0) are given the value of 0.

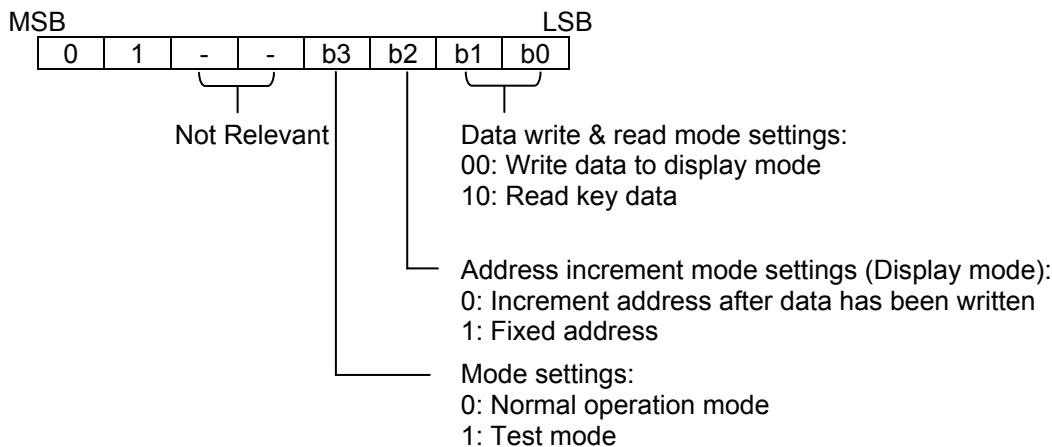

PT6964 KEY MATRIX & KEY INPUT DATA STORAGE RAM

PT6964 Key Matrix consists of 10 x 2 array as shown below:

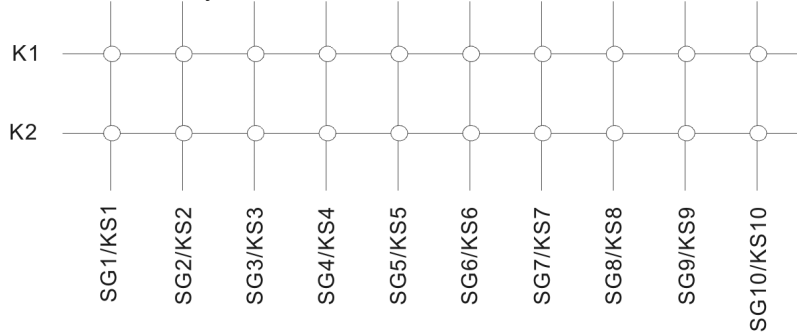

Each data entered by each key is stored as follows and read by a READ Command, starting from the last significant bit. When the most significant bit of the data (b7) has been read, the least significant bit of the next data (b0) is read.

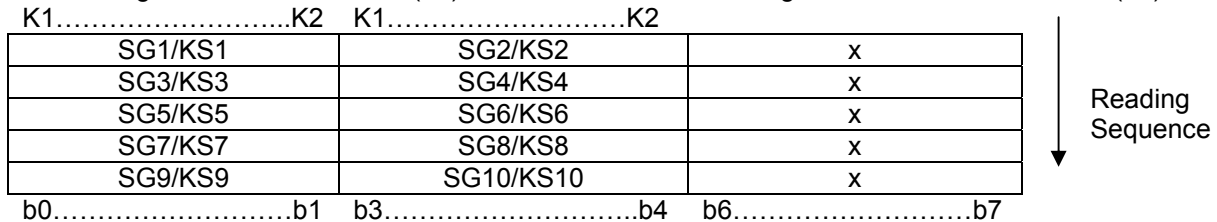

Note: b6 and b7 do not care.

COMMANDS 3: ADDRESS SETTING COMMANDS

Address Setting Commands are used to set the address of the display memory. The address is considered valid if it has a value of 00H to 0DH. If the address is set to 0EH or higher, the data is ignored until a valid address is set. When power is turned ON, the address is set at 00H.

Please refer to the diagram below.

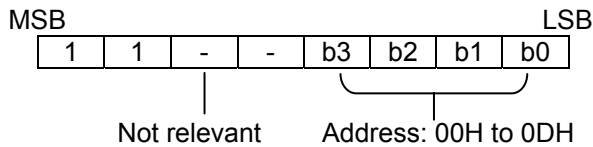

DISPLAY MODE AND RAM ADDRESS

Data transmitted from an external device to PT6964 via the serial interface are stored in the Display RAM and are assigned addresses. The RAM addresses of PT6964 are given below in 8 bits unit.

SG1	SG4	SG5	SG8	SG9	SG10	X	SG12	SG13	SG14	
00HL		00HU		01HL		-			01HU	DIG1
02HL		02HU		03HL		-			03HU	DIG2
04HL		04HU		05HL		-			05HU	DIG3
06HL		06HU		07HL		-			07HU	DIG4
08HL		08HU		09HL		-			09HU	DIG5
0AHL		0AHU		0BHL		-			0BHU	DIG6
0CHL		0CHU		0DHL		-			0DHU	DIG7

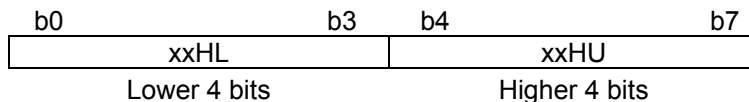

Note: X = Not relevant

COMMAND 4: DISPLAY CONTROL COMMANDS

The Display Control Commands are used to turn ON or OFF a display. It also used to set the pulse width. Please refer to the diagram below. When the power is turned ON, a 1/16 pulse width is selected and the displayed is turned OFF (the key scanning is started).

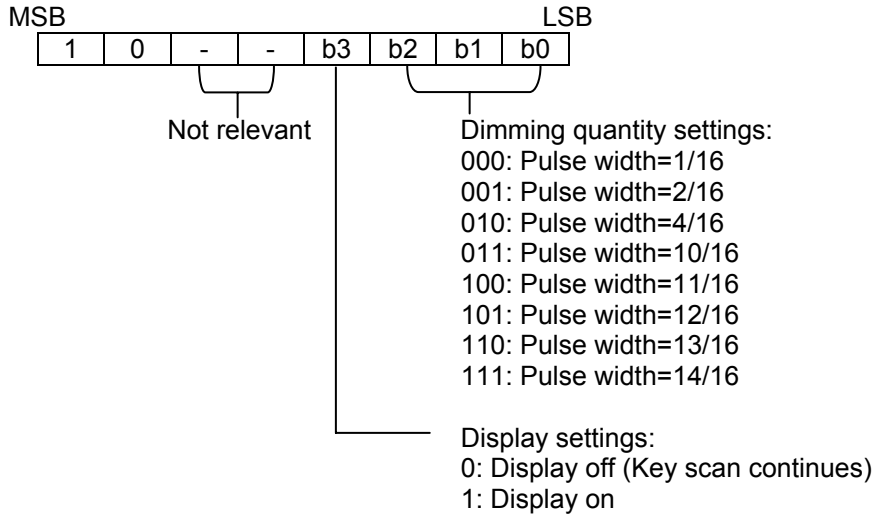

SCANNING AND DISPLAY TIMING

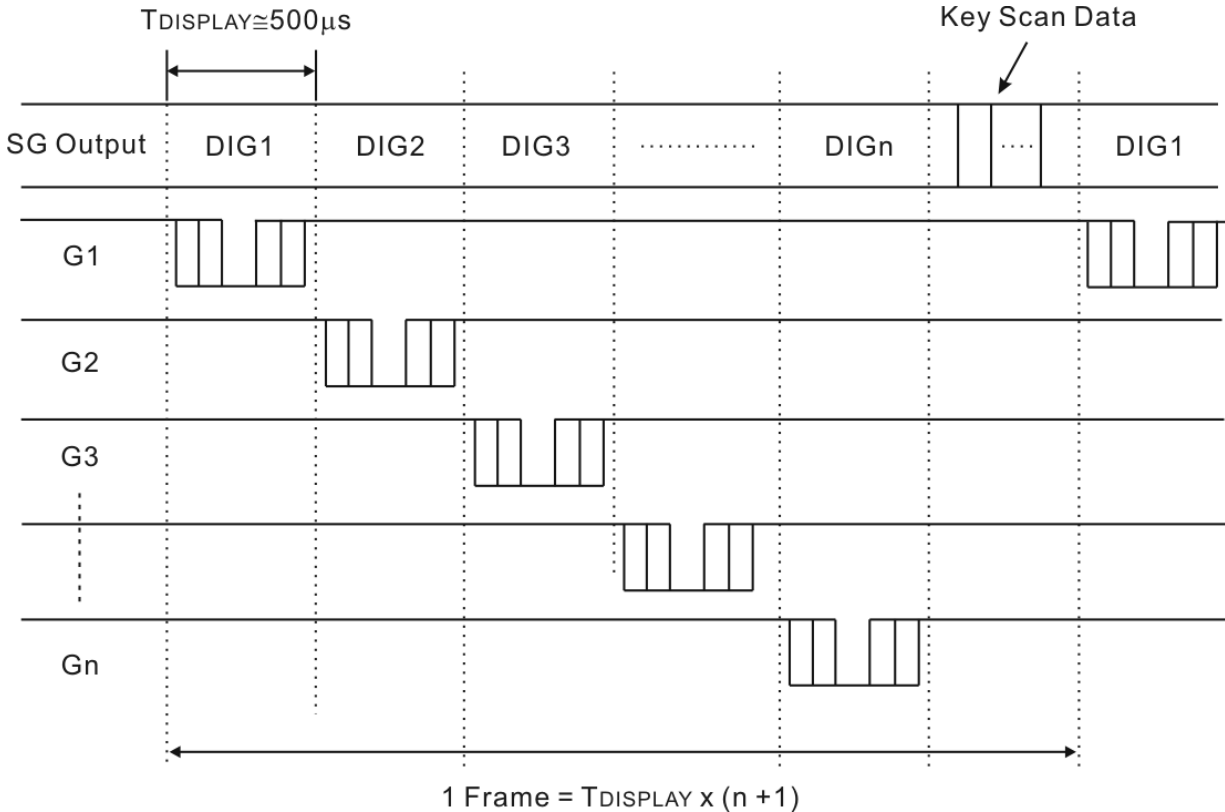

SERIAL COMMUNICATION FORMAT

The following diagram shows the PT6964 serial communication format. The DI/O Pin is an N-channel, open-drain output pin, therefore, it is highly recommended that an external pull-up resistor (1KΩ to 10KΩ) must be connected to DI/O.

RECEPTION (DATA/COMMAND WRITE)

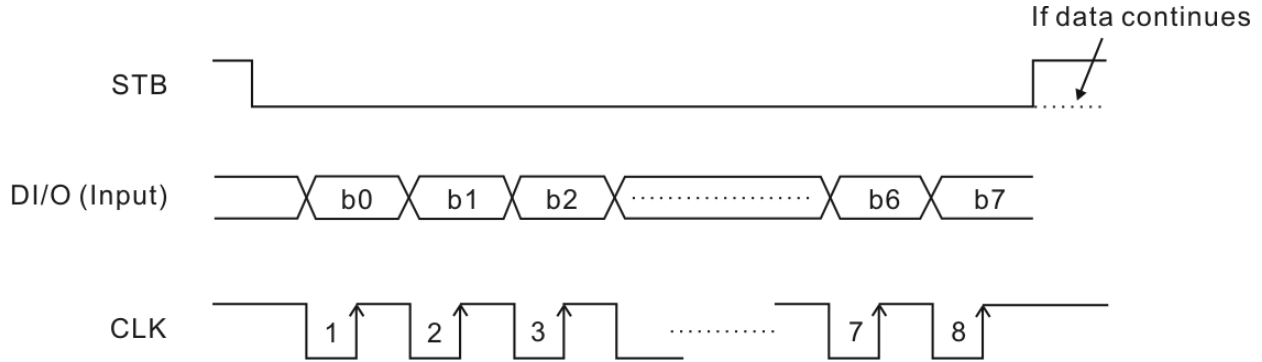

TRANSMISSION (DATA READ)

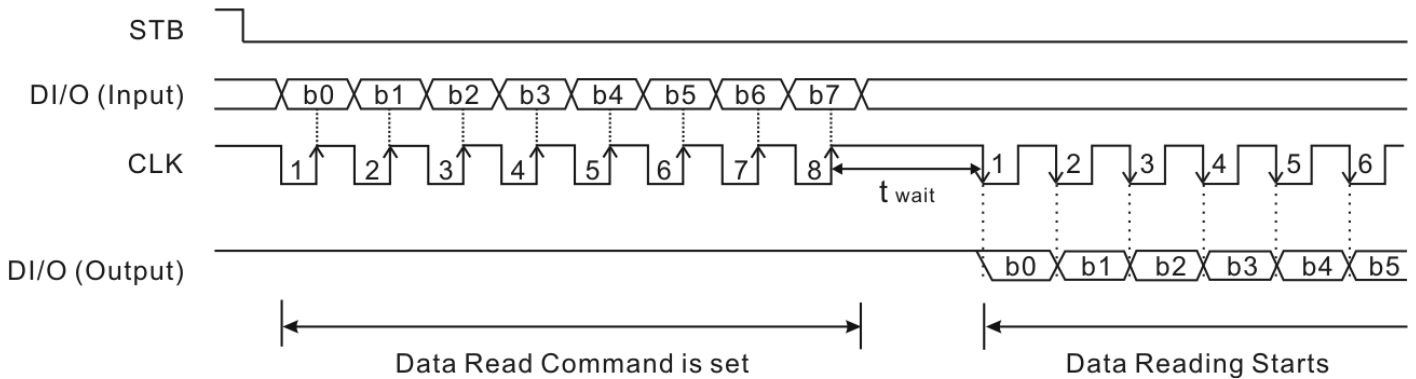

where: t_{wait} (waiting time) $\geq 1\mu s$

It must be noted that when the data is read, the waiting time (t_{wait}) between the rising of the eighth clock that has set the command and the falling of the first clock that has read the data is greater or equal to 1μs.

SWITCHING CHARACTERISTIC WAVEFORM

PT6964 Switching Characteristics Waveform is given below.

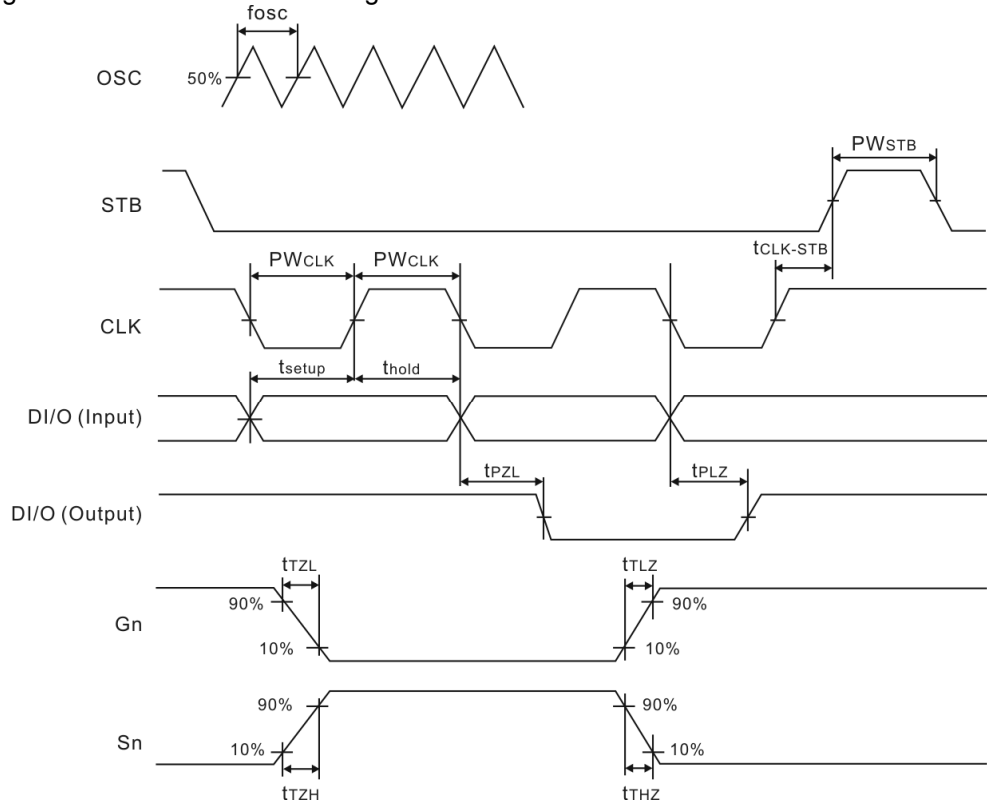

where:

f_{osc} = Oscillation Frequency
 PW_{STB} (Strobe Pulse Width) $\geq 1\mu s$
 t_{setup} (Data Setup Time) $\geq 100ns$
 t_{THZ} (Segment Rise Time) $\leq 1\mu s$
 t_{TZL} (Grid Fall Time) $\leq 1\mu s$
 t_{PZL} (Propagation Delay Time) $\leq 100ns$

PW_{CLK} (Clock Pulse Width) $\geq 400ns$
 $t_{CLK-STB}$ (Clock - Strobe Time) $\geq 1\mu s$
 t_{hold} (Data Hold Time) $\geq 100ns$
 t_{THZ} (Segment Fall Time) $\leq 10\mu s$
 t_{TLZ} (Grid Rise Time) $\leq 10\mu s$
 t_{PLZ} (Propagation Delay Time) $\leq 300ns$

Note:

Test Condition Under
 t_{THZ} (Pull low resistor=10K Ω , Loading capacitor=300pF)
 t_{TLZ} (Pull high resistor=10K Ω , Loading capacitor=300pF)

APPLICATIONS

Display memory is updated by incrementing addresses. Please refer to the following diagram.

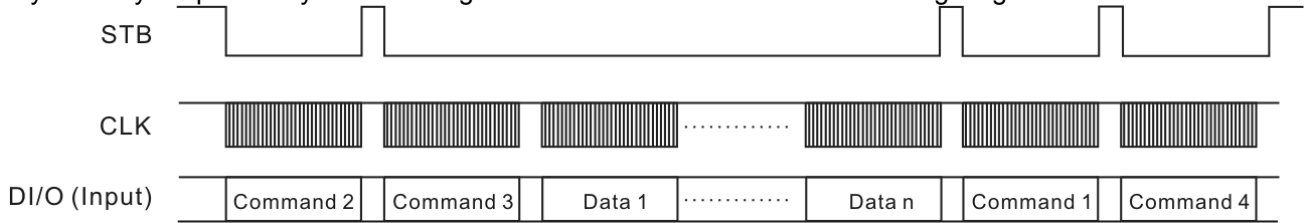

where:

- Command 1: Display mode setting command
- Command 2: Data setting command
- Command 3: Address setting command
- Data 1 to n: Transfer display data (14 bytes max.)
- Command 4: Display control command

The following diagram shows the waveforms when updating specific addresses.



where:

- Command 2: Data setting command
- Command 3: Address setting command
- Data: Data display data

RECOMMENDED SOFTWARE FLOWCHART

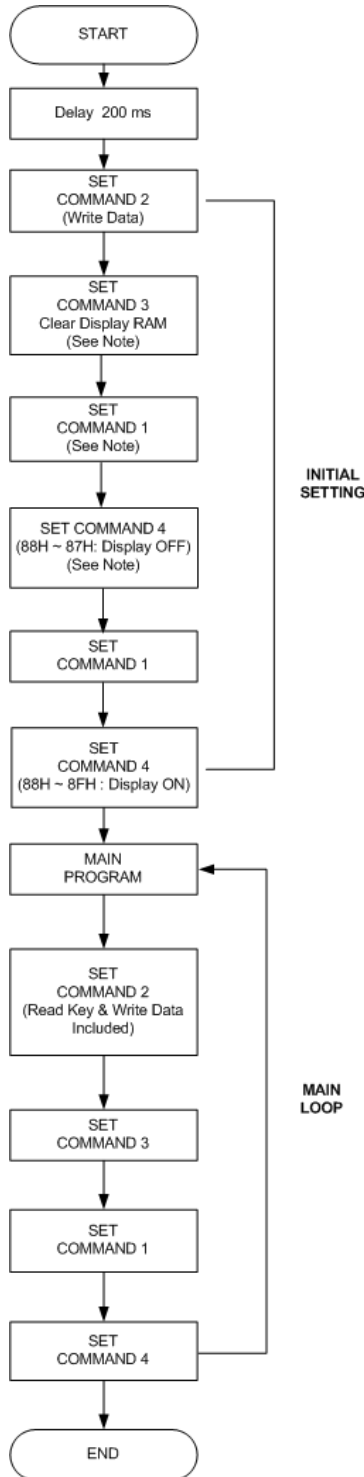

Notes:

1. Command 1: Display Mode Commands
2. Command 2: Data Setting Commands
3. Command 3: Address Setting Commands
4. Command 4: Display Control Commands
5. When IC power is applied for the first time, the content of the Display RAM is not defined; thus, it is strongly suggested that the contents of the Display RAM be cleared during the initial setting.

SOP 28 (300MIL) THERMAL PERFORMANCE IN STILL AIR

JUNCTION TEMPERATURE: 100 °C

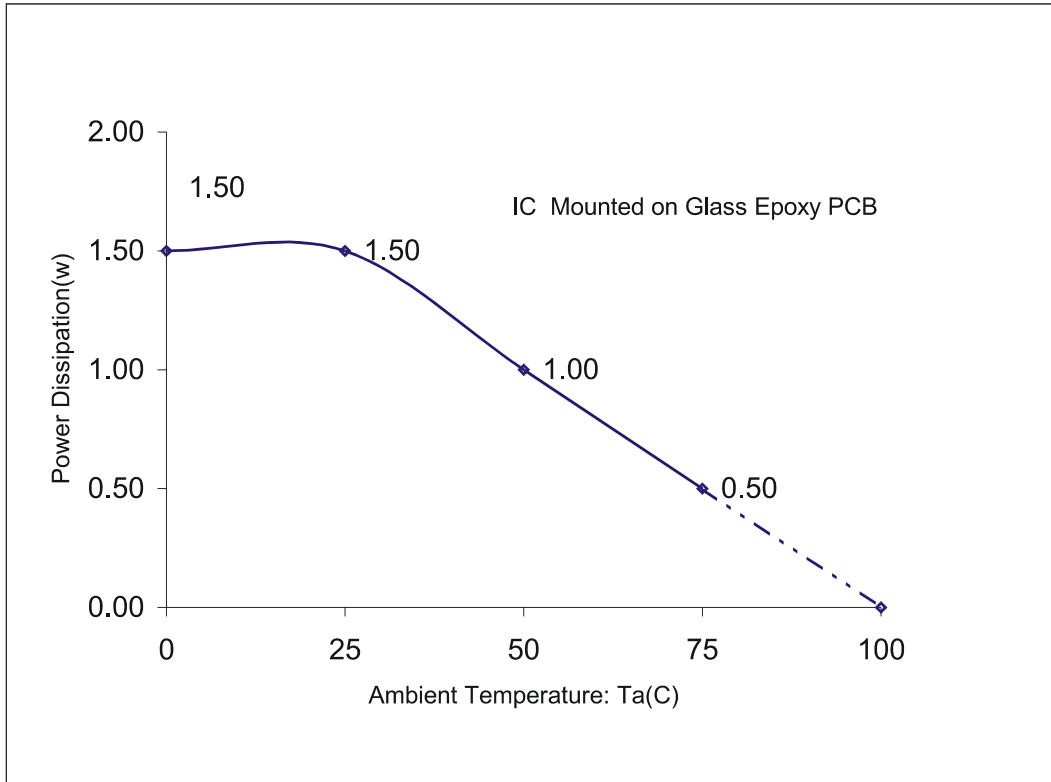

ABSOLUTE MAXIMUM RATING

(Unless otherwise stated, Ta=25°C, GND=0V)

Parameter	Symbol	Rating	Unit
Supply voltage	VDD	-0.3 to +7	V
Logic input voltage	VI	-0.3 to VDD+0.3	V
Driver output current	IOLGR	+200	mA
	IOHSG	-50	mA
Maximum driver output current/total	ITOTAL	400	mA
Operating temperature	Topr	-40 ~ +85	°C
Storage temperature	Tstg	-65 ~ +150	°C

RECOMMENDED OPERATING RANGE

(Unless otherwise stated, Ta=25°C, GND=0V)

Parameter	Symbol	Min.	Typ.	Max.	Unit
Logic supply voltage	VDD	4.5	5	5.5	V
Dynamic current (see Note)	IDDdyn	-	-	5	mA
High-level input voltage	VIH	0.8VDD	-	VDD	V
Low-level input voltage	VIL	0	-	0.3VDD	V

Note: Test Condition: Set Display Control Commands=80H (Display Turn OFF State & under no load)

ELECTRICAL CHARACTERISTICS

(Unless otherwise stated, VDD=5V, GND=0V, Ta=25°C)

Parameter	Symbol	Test Condition	Min.	Typ.	Max.	Unit
High-level output current	IOHSG(1)	VO=VDD-2V SG1/KS1 to SG10/KS10, SG12/GR7 to SG14/GR5	-20	-25	-40	mA
	IOHSG(2)	VO=VDD-3V SG1/KS1 to SG10/KS10, SG12/GR7 to SG14/GR5	-25	-30	-50	mA
Low-level output current	IOLGR	VO=0.3V GR1 to GR4 SG14/GR5 to SG12/GR7	100	140	-	mA
Low-level output current	IOLDI/O	VO=0.4V	4	-	-	mA
Segment high-level output current tolerance	ITOLSG	VO=VDD-3V SG1/KS1 to SG10/KS10, SG12/GR7 to SG14/GR5	-	-	±5	%
High-level input voltage	VIH	-	0.8VDD	-	5	V
Low-level input voltage	VIL	-	0	-	0.3VDD	V
Oscillation frequency	fosc	R=51KΩ	350	500	650	KHz
K1 to K3 pull down resistor	RKN	K1 to K2; VDD=5V	40	-	100	KΩ

PACKAGE INFORMATION

28 PINS, SOP, 300MIL

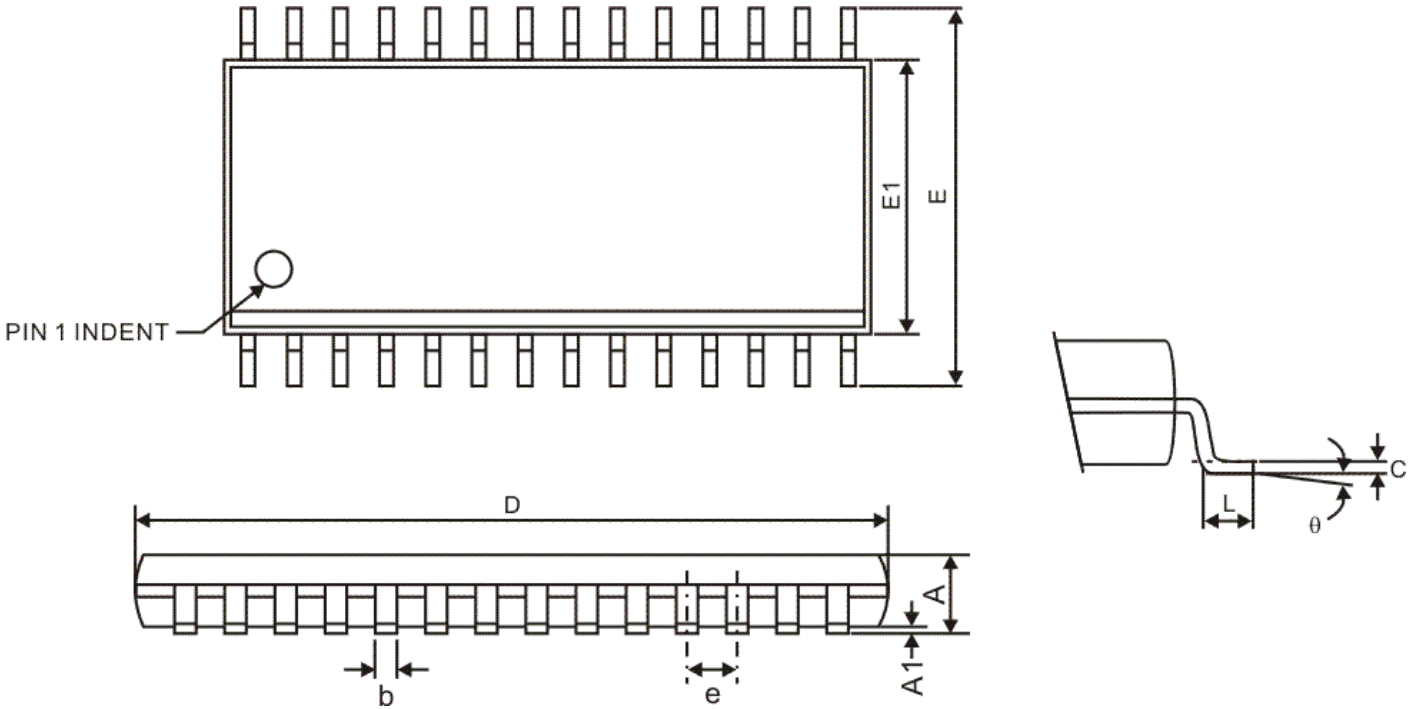

Symbol	Min.	Nom.	Max.
A	-	-	2.65
A1	-	-	0.30
b	0.31	-	0.51
c	0.20	-	0.33
D	17.90 BSC		
E	10.30 BSC		
E1	7.50 BSC		
e	1.27 BSC		
L	0.38	-	1.27
θ	0°	-	8°

Notes:
 1. All controlling dimensions are in millimeters.
 2. Refer to JEDEC MS-012AE

IMPORTANT NOTICE

Princeton Technology Corporation (PTC) reserves the right to make corrections, modifications, enhancements, improvements, and other changes to its products and to discontinue any product without notice at any time.

PTC cannot assume responsibility for use of any circuitry other than circuitry entirely embodied in a PTC product. No circuit patent licenses are implied.

Princeton Technology Corp.
2F, 233-1, Baociao Road,
Sindian, Taipei 23145, Taiwan
Tel: 886-2-66296288
Fax: 886-2-29174598
<http://www.princeton.com.tw>