

Discovery kit with STM32F411VE MCU

Introduction

The STM32F411 Discovery kit (32F411EDISCOVERY) helps you to discover the entry level of the STM32F4 series and to develop your applications. It is based on an STM32F411VET6 microcontroller and includes an ST-LINK/V2 embedded debug tool interface, ST MEMS Gyroscope, ST MEMS accelerometer + magnetometer, ST MEMS digital microphone, audio DAC with integrated class D speaker driver, LEDs, pushbuttons and a USB OTG micro-AB connector.

Figure 1. STM32F411 Discovery board

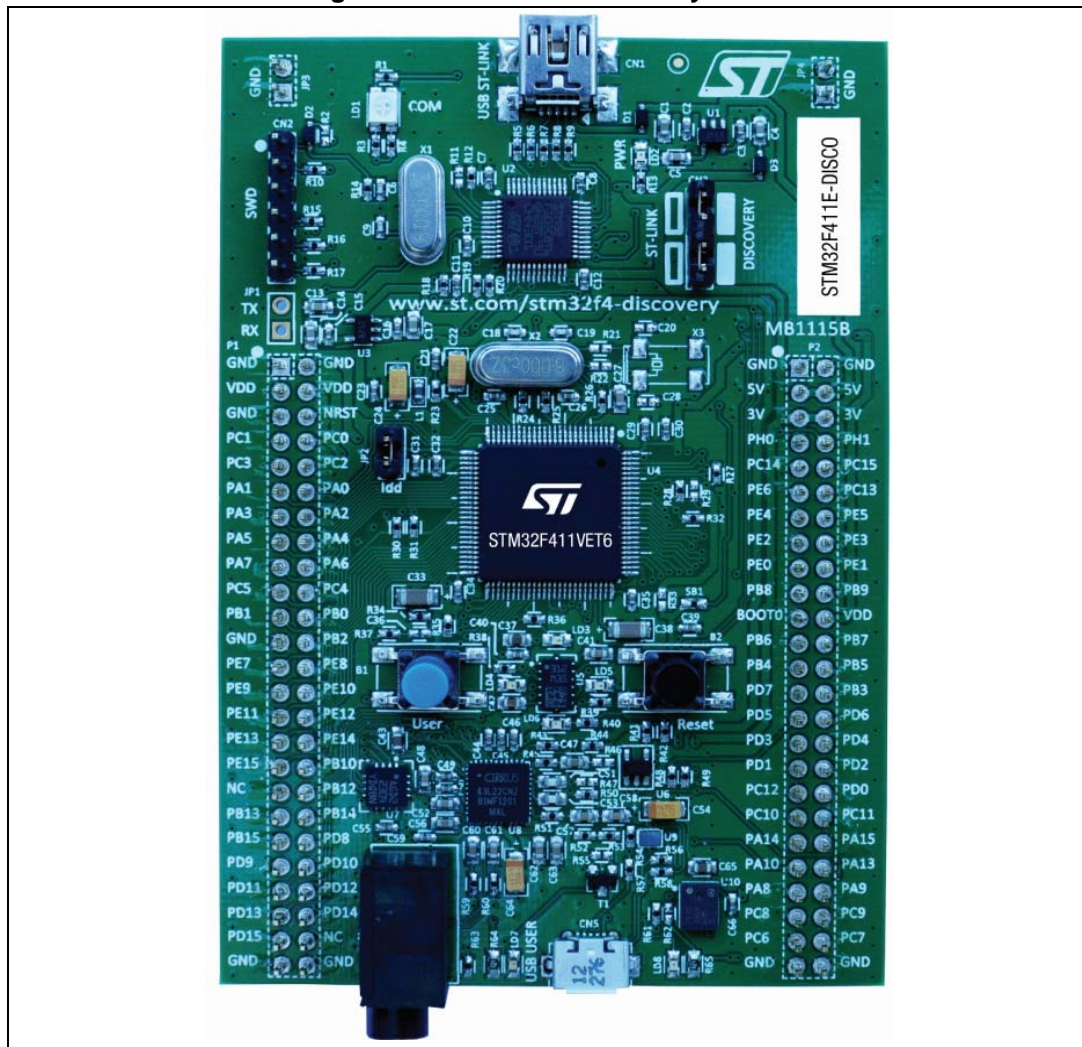

Contents

- 1 Conventions 6**
- 2 Quick start 7**
 - 2.1 Getting started 7
 - 2.2 System requirements 7
 - 2.3 Development toolchains supporting the STM32F411 Discovery kit 7
 - 2.4 Order code 7
- 3 Features 8**
- 4 Hardware layout 9**
 - 4.1 Embedded ST-LINK/V2 12
 - 4.1.1 Using ST-LINK/V2 to program/debug the STM32F411 on board 13
 - 4.1.2 Using ST-LINK/V2 to program/debug an external STM32 application .. 14
 - 4.2 Power supply and power selection 15
 - 4.3 LEDs 15
 - 4.4 Pushbuttons 15
 - 4.5 On board audio capability 16
 - 4.6 USB OTG supported 16
 - 4.7 E-compass MEMS (ST MEMS LSM303DLHC) 16
 - 4.8 Gyroscope MEMS (ST MEMS L3GD20) 16
 - 4.9 JP2 (Idd) 17
 - 4.10 OSC clock 17
 - 4.10.1 OSC clock supply 17
 - 4.10.2 OSC 32 KHz clock supply 17
 - 4.11 BOOT0 configuration 18
 - 4.12 Solder bridges 18
 - 4.13 Extension connectors 19
- 5 Mechanical drawing 27**
- 6 Electrical schematics 28**



7 **Revision history** **34**

List of tables

Table 1.	ON/OFF conventions	6
Table 2.	Jumper states	12
Table 3.	Debug connector CN2 (SWD)	14
Table 4.	Solder bridges	18
Table 5.	MCU pin description versus board function	19
Table 6.	Document revision history	34

List of figures

Figure 1.	STM32F411 Discovery board	1
Figure 2.	Hardware block diagram	9
Figure 3.	Top layout	10
Figure 4.	Bottom layout	11
Figure 5.	Typical configuration	12
Figure 6.	STM32F411 Discovery board connections image	13
Figure 7.	ST-LINK connections image	14
Figure 8.	STM32F411 Discovery board mechanical drawing	27
Figure 9.	STM32F411 Discovery board	28
Figure 10.	ST-LINK/V2 (SWD only)	29
Figure 11.	STM32F411VET6 MCU	30
Figure 12.	Audio	31
Figure 13.	USB_OTG_FS	32
Figure 14.	Peripherals	33

1 Conventions

Table 1 provides the definition of some conventions used in the present document.

Table 1. ON/OFF conventions

Convention	Definition
Jumper JPx ON	Jumper fitted
Jumper JPx OFF	Jumper not fitted
Solder bridge SBx ON	SBx connections closed by solder
Solder bridge SBx OFF	SBx connections left open

2 Quick start

The STM32F411 Discovery is a low-cost and easy-to-use development kit to quickly evaluate and start a development with an STM32F4 entry level microcontroller.

Before installing and using the product, please accept the Evaluation Product License Agreement from www.st.com/stm32f4-discovery.

For more information on the STM32F411 Discovery board and for demonstration software, visit www.st.com/stm32f4-discovery.

2.1 Getting started

Follow the sequence below to configure the STM32F411 Discovery board and launch the DISCOVER application:

1. Ensure that the jumpers JP2 and CN3 are set to "on" (Discovery mode).
2. Connect the STM32F411 Discovery board to a PC using a USB cable type A/mini-B through the USB ST-LINK connector CN1, to power the board. The LED LD2 (PWR) will light up and the four LEDs between the buttons B1 and B2 start blinking.
3. Press the user button B1 to enable the MEMS sensor. The four LEDs will indicate the board motion direction and speed. When connected to a PC with a second USB type A/micro-B cable through CN5, the board will be recognized as a standard mouse.
4. The demo software, as well as other software examples that allow you to discover the STM32 F4 series features, are available on www.st.com/stm32f4-discovery.
5. Develop your own applications starting from the examples.

2.2 System requirements

- Windows PC (XP, 7,8)
- USB type A to mini-B cable

2.3 Development toolchains supporting the STM32F411 Discovery kit

- Keil®: MDK-ARM
- IAR: EWARM
- GCC-based IDEs (Atollic TrueStudio,...)

2.4 Order code

To order the Discovery kit for STM32F411 microcontrollers, use the order code: STM32F411E-DISCO.

3 Features

The STM32F411 Discovery board offers the following features:

- STM32F411VET6 microcontroller featuring 512 KB of Flash memory, 128 KB of RAM in an LQFP100 package
- On-board ST-LINK/V2 with selection mode switch to use the kit as a standalone ST-LINK/V2 (with SWD connector for programming and debugging)
- Board power supply: through USB bus or from an external 5 V supply voltage
- External application power supply: 3 V and 5 V
- L3GD20, ST MEMS motion sensor, 3-axis digital output gyroscope.
- LSM303DLHC, ST MEMS system-in-package featuring a 3D digital linear acceleration sensor and a 3D digital magnetic sensor.
- MP45DT02, ST MEMS audio sensor, omnidirectional digital microphone
- CS43L22, audio DAC with integrated class D speaker driver
- Eight LEDs:
 - LD1 (red/green) for USB communication
 - LD2 (red) for 3.3 V power on
 - Four user LEDs:
LD3 (orange), LD4 (green), LD5 (red) and LD6 (blue)
 - Two USB OTG LEDs:
LD7 (green) VBus and LD8 (red) over-current
- Two pushbuttons (user and reset)
- USB OTG with micro-AB connector
- Extension header for LQFP100 I/Os for a quick connection to the prototyping board and an easy probing

4 Hardware layout

The STM32F411 Discovery board has been designed around the STM32F411VET6 microcontroller in a 100-pin LQFP package.

Figure 2 illustrates the connections between the STM32F411VET6 and its peripherals (ST-LINK/V2, pushbutton, LED, Audio DAC, USB, ST MEMS gyroscope, ST MEMS accelerometer + magnetometer, ST MEMS microphone, and connectors).

Figure 3 and *Figure 4* help you to locate these features on the STM32F411 Discovery board.

Figure 2. Hardware block diagram

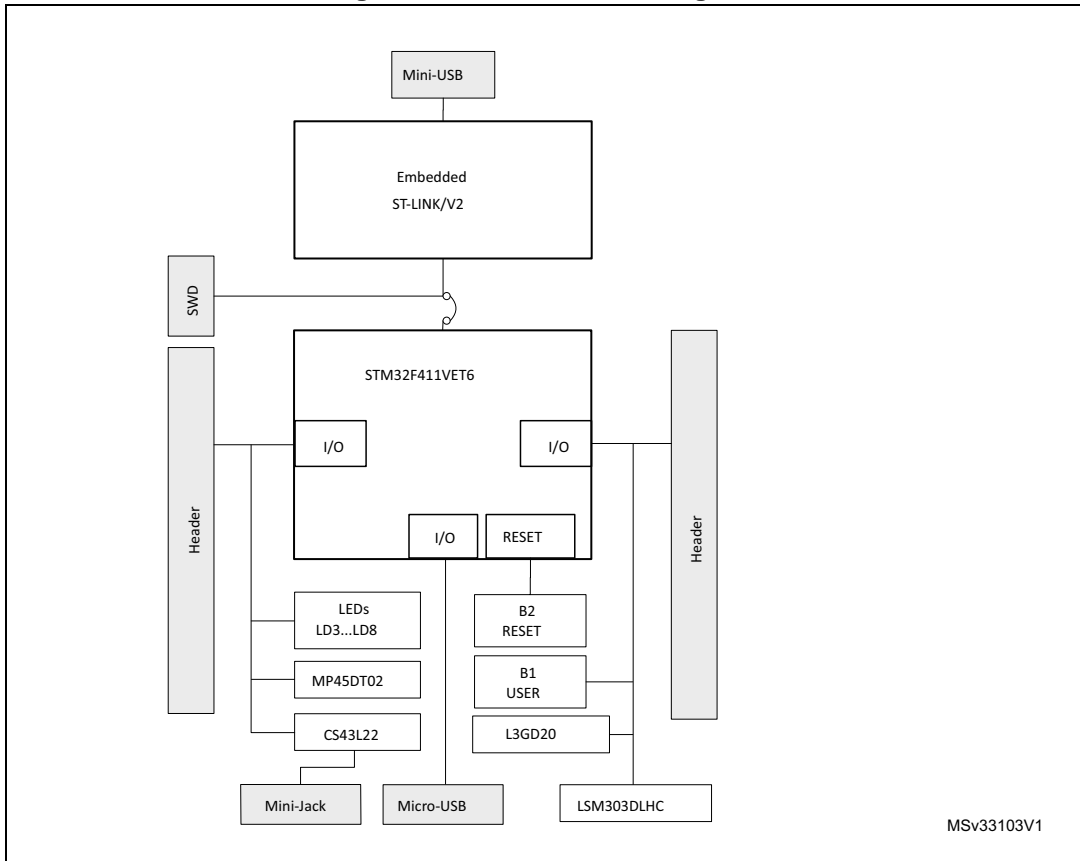
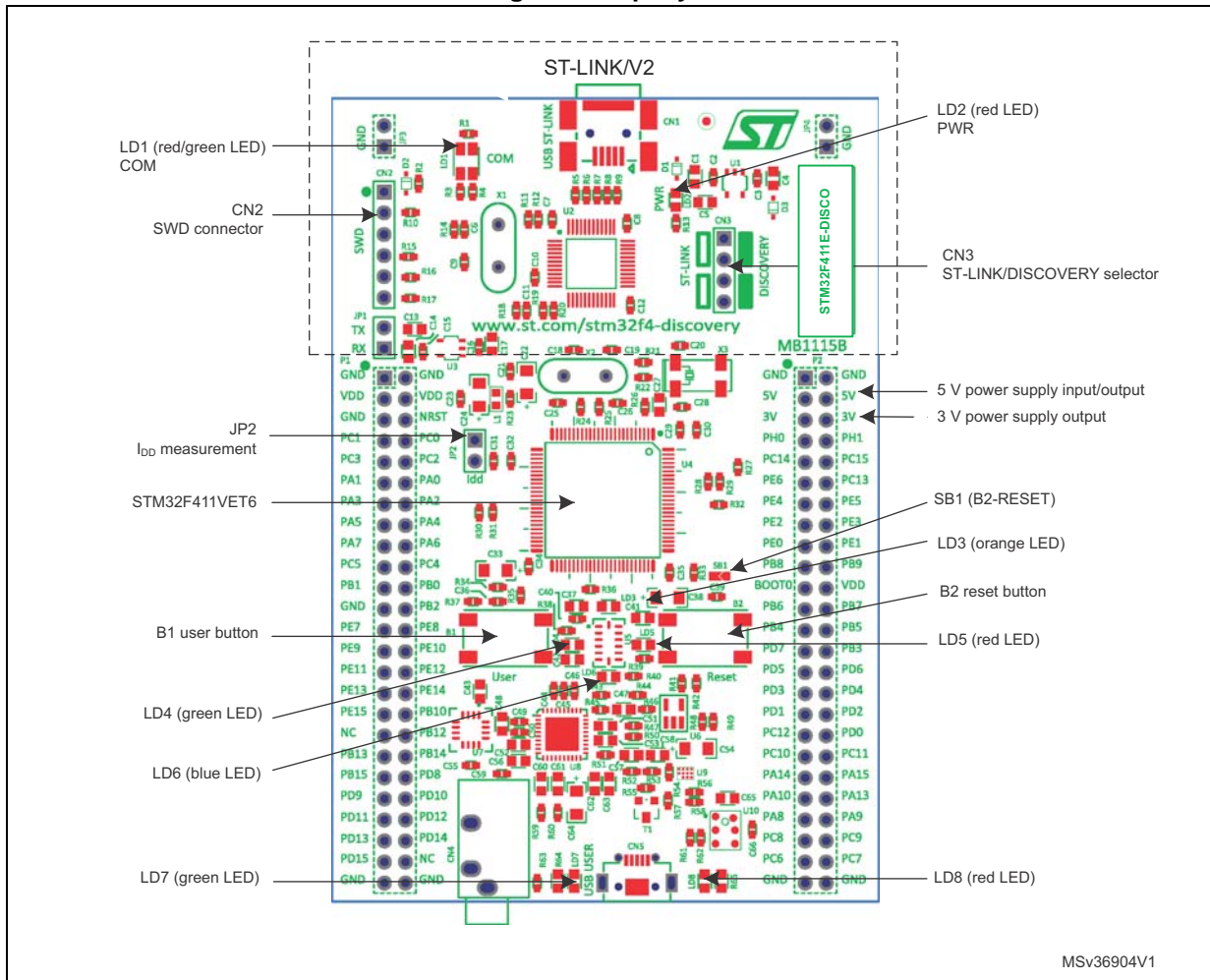
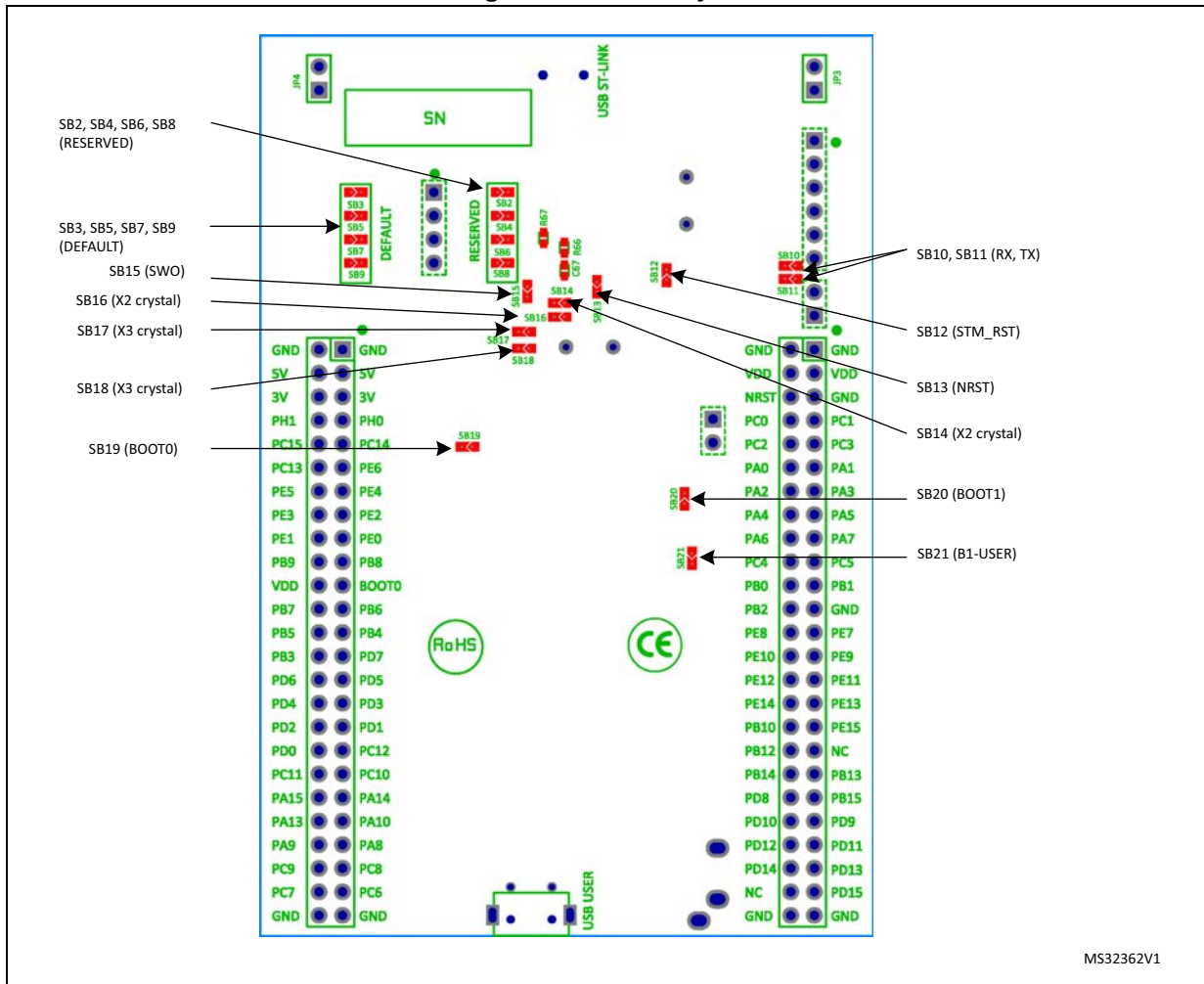

Figure 3. Top layout



MSV36904V1

Figure 4. Bottom layout



4.1 Embedded ST-LINK/V2

The ST-LINK/V2 programming and debugging tool is integrated on the STM32F411 Discovery board. The embedded ST-LINK/V2 can be used in 2 different ways according to the jumper states (see [Table 2](#)):

- Program/debug the MCU on board,
- Program/debug an MCU in an external application board using a cable connected to SWD connector CN2.

The embedded ST-LINK/V2 supports only SWD for STM32 devices. For information about debugging and programming features, refer to user manual UM1075 (ST-LINK/V2 in-circuit debugger/programmer for STM8 and STM32) which describes in detail all the ST-LINK/V2 features.

Figure 5. Typical configuration

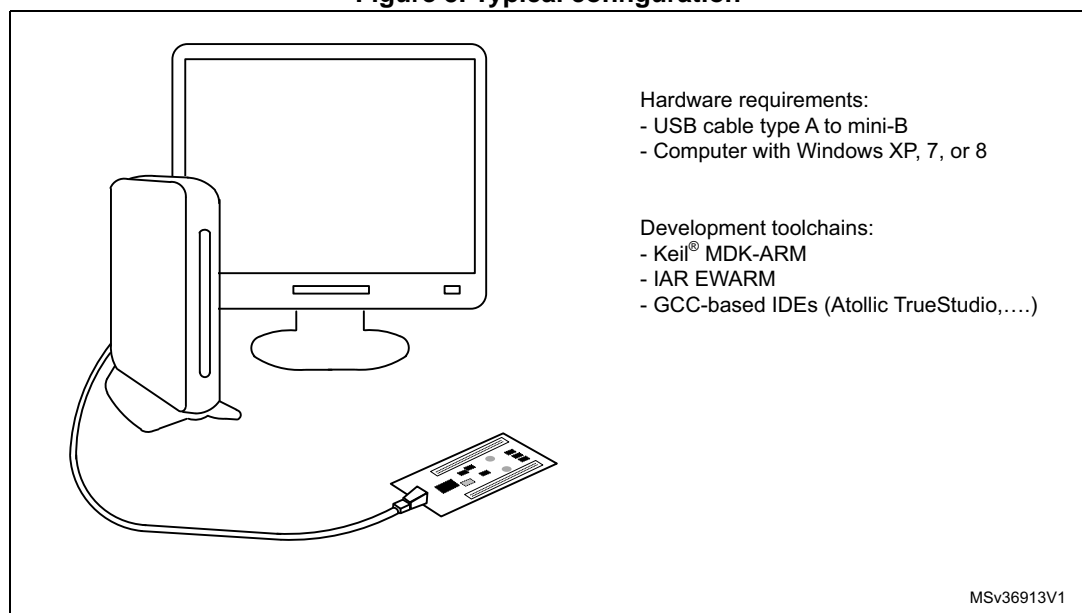

Table 2. Jumper states

Jumper state	Description
Both CN3 jumpers ON	ST-LINK/V2 functions enabled for on board programming (default)
Both CN3 jumpers OFF	ST-LINK/V2 functions enabled for application through external CN2 connector (SWD supported)

4.1.1 Using ST-LINK/V2 to program/debug the STM32F411 on board

To program the STM32F411 on board, simply plug in the two jumpers on CN3, as shown in [Figure 6](#) in red, but do not use the CN2 connector as that could disturb communication with the STM32F411VET6 of the STM32F411 Discovery board.

Figure 6. STM32F411 Discovery board connections image

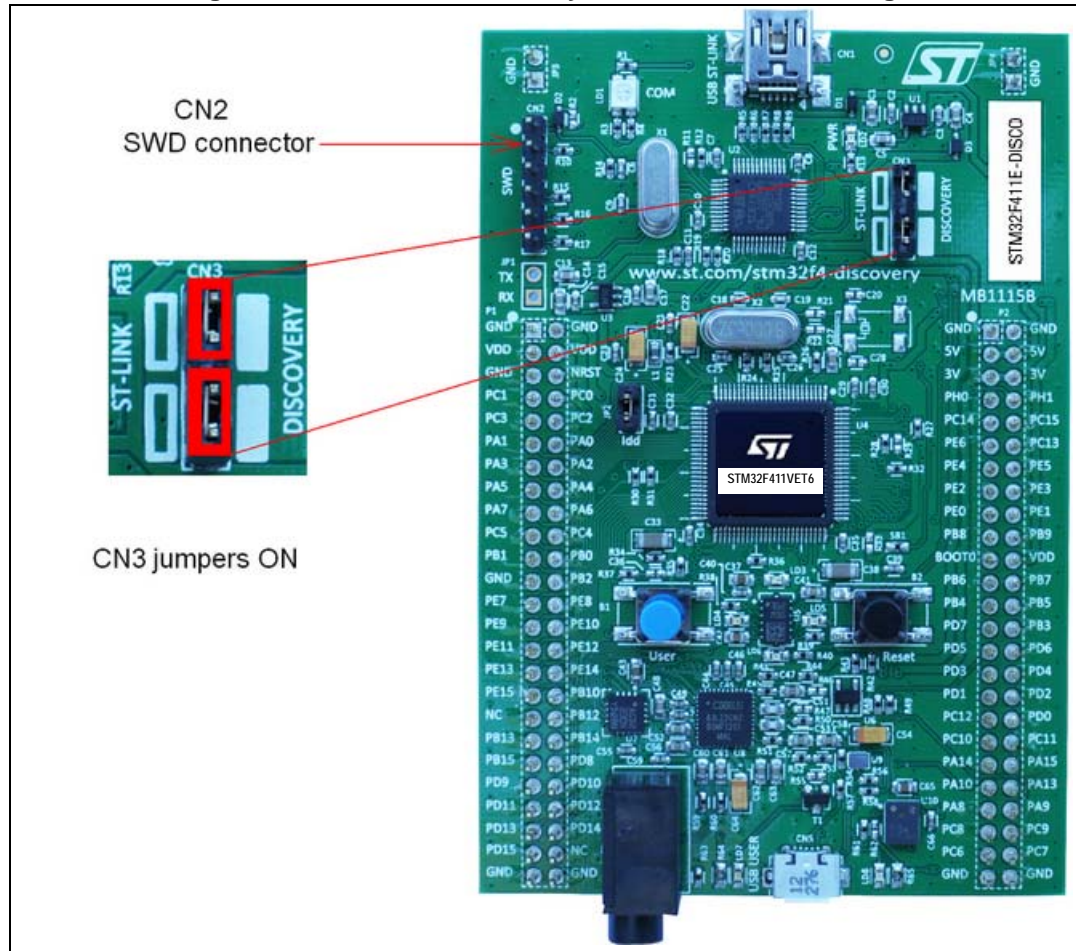

4.1.2 Using ST-LINK/V2 to program/debug an external STM32 application

It is very easy to use the ST-LINK/V2 to program the STM32 on an external application. Simply remove the 2 jumpers from CN3 as shown in [Figure 7](#), and connect your application to the CN2 debug connector according to [Table 3](#).

Note: SB13 must be OFF if you use CN2 pin 5 in your external application.

Table 3. Debug connector CN2 (SWD)

Pin	CN2	Designation
1	VDD_TARGET	VDD from application
2	SWCLK	SWD clock
3	GND	Ground
4	SWDIO	SWD data input/output
5	NRST	RESET of target MCU
6	SWO	Reserved

Figure 7. ST-LINK connections image

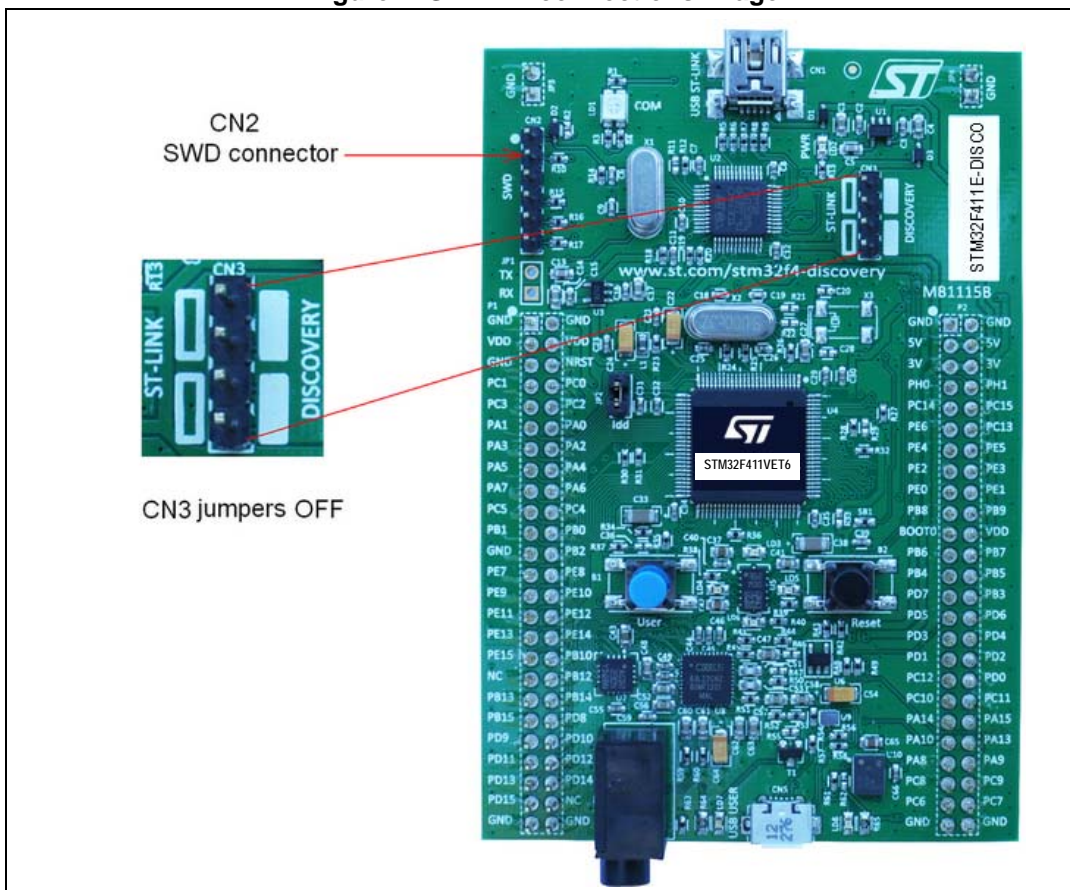

4.2 Power supply and power selection

The power supply is provided either by the host PC through the USB cable, or by an external 5 V power supply.

The D1 and D2 diodes protect the 5 V and 3 V pins from external power supplies:

- 5 V and 3 V can be used as output power supplies when another application board is connected to pins P1 and P2.
In this case, the 5 V and 3 V pins deliver a 5 V or 3 V power supply and the power consumption must be lower than 100 mA.
- 5 V can also be used as input power supplies, e.g. when the USB connector is not connected to the PC.
In this case, the STM32F411 Discovery board must be powered by a power supply unit or by an auxiliary equipment complying with standard EN-60950-1: 2006+A11/2009, and must be Safety Extra Low Voltage (SELV) with limited power capability.

4.3 LEDs

- LD1 COM:
LD1 default status is red. LD1 turns to green to indicate that communications are in progress between the PC and the ST-LINK/V2.
- LD2 PWR:
The red LED indicates that the board is powered.
- User LD3:
The orange LED is a user LED connected to the I/O PD13 of the STM32F411VET6.
- User LD4:
The green LED is a user LED connected to the I/O PD12 of the STM32F411VET6.
- User LD5:
The red LED is a user LED connected to the I/O PD14 of the STM32F411VET6.
- User LD6:
The blue LED is a user LED connected to the I/O PD15 of the STM32F411VET6.
- USB LD7:
The green LED indicates when VBUS is present on CN5 and is connected to PA9 of the STM32F411VET6.
- USB LD8:
The red LED indicates an overcurrent from VBUS of CN5 and is connected to the I/O PD5 of the STM32F411VET6.

4.4 Pushbuttons

- B1 USER:
User and Wake-Up button connected to the I/O PA0 of the STM32F411VET6.
- B2 RESET:
The pushbutton connected to NRST is used to RESET the STM32F411VET6.

4.5 On board audio capability

The STM32F411 uses an audio DAC (CS43L22) to output sounds through the audio mini jack connector.

The STM32F411 controls the audio DAC through the I²C interface and processes digital signals through an I2S connection or analog input signal.

- The sound can come independently from different inputs:
 - ST MEMS microphone (MP45DT02): digital using PDM protocol or analog when using the low pass filter.
 - USB connector: from external mass storage such as a USB key, USB HDD, and so on.
 - Internal memory of the STM32F411.
- The sound can be output in different ways through audio DAC:
 - Using the I2S protocol
 - Using the microphone output directly via a low pass filter to analog input AIN4x of the CS43L22

4.6 USB OTG supported

The STM32F411 is used to drive only USB OTG full speed on this board. The USB micro-AB connector (CN5) allows the user to connect a host or device component, such as a USB key, mouse, and so on.

Two LEDs are dedicated to this module:

- LD7 (green LED) indicates when VBUS is active
- LD8 (red LED) indicates an overcurrent from a connected device.

4.7 E-compass MEMS (ST MEMS LSM303DLHC)

The LSM303DLHC is an ultra-compact low-power system-in-package featuring a 3D digital linear acceleration sensor and a 3D digital magnetic sensor. It includes a sensing element and an IC interface able to provide the measured acceleration to the external world through an I2C serial interface.

The LSM303DLHC has dynamically user-selectable full scales of $\pm 2g/\pm 8g$ and is capable of measuring the acceleration, and a magnetic field full scale from $\pm 1.3 g$ to $8.1 g$ with an output data rate of 100 Hz or 400 Hz.

The STM32F411VET6 MCU controls this motion sensor through the I2C interface.

4.8 Gyroscope MEMS (ST MEMS L3GD20)

The L3GD20 is an ultra-compact, low-power, three-axis angular rate sensor. It includes a sensing element and an IC interface able to provide the measured angular rate to the external world through the I2C/SPI serial interface.

The L3GD20 has dynamically user-selectable full scales of $\pm 250 \text{ dps}/500 \text{ dps}/\pm 2000 \text{ dps}$ and is capable of measuring rates.

The STM32F411VET6 MCU controls this motion sensor through the SPI interface.

4.9 JP2 (Idd)

Jumper JP2, labeled Idd, allows the consumption of STM32F411VET6 to be measured by removing the jumper and connecting an ammeter.

- Jumper on: STM32F411VET6 is powered (default).
- Jumper off: an ammeter must be connected to measure the STM32F411VET6 current, (if there is no ammeter, the STM32F411VET6 is not powered).

4.10 OSC clock

4.10.1 OSC clock supply

If PH0 and PH1 are only used as GPIOs instead of as a clock, then SB14 and SB16 are closed and R24, R25 and R66 are removed.

MCO from ST-LINK (from MCO of the STM32F103)

This frequency cannot be changed, it is fixed at 8 MHz and connected to PH0-OSC_IN of the STM32F411VET6. The configuration needed is:

- SB14, SB16 OPEN
- R25 removed
- R66 soldered

Oscillator onboard (from X2 crystal)

For typical frequencies and its capacitors and resistors, please refer to the STM32F411VET6 Datasheet. The configuration needed is:

- SB14, SB16 OPEN
- R25 soldered
- R66 removed

Oscillator from external PH0 (from external oscillator through pin 7 of the P2 connector)

The configuration needed is:

- SB14 closed
- SB16 closed
- R25 and R66 removed

4.10.2 OSC 32 KHz clock supply

If PC14 and PC15 are only used as GPIOs instead of as a clock, then SB17 and SB18 are closed, and R21 and R22 are removed.

Oscillator onboard (from X1 Crystal (not provided))

The configuration needed is:

- SB17, SB18 OPEN
- C20, C28, R21 and R22 soldered

Oscillator from external PC14 (from external oscillator through the pin 9 of P2 connector)
 The configuration needed is:

- SB17 closed
- SB18 closed
- R21 and R22 removed

4.11 BOOT0 configuration

BOOT0 is at level "0" through a pull-down R28. If you want to set BOOT0 at level "1", it can be configured by setting a jumper between P2.21 (BOOT0) and P2.22 (V_{DD}).

Note: If you need to set BOOT0 at level "1" continuously, then open SB19 solder bridge to avoid a consumption of 6 mA, while connecting pin P2.21 and P2.22 with a jumper or with a wire.

4.12 Solder bridges

Table 4. Solder bridges

Bridge	State ⁽¹⁾	Description
SB14,16 (X2 crystal)	OFF	X2, C18, C19, R24 and R25 provide a clock. PH0, PH1 are disconnected from P2
	ON	PH0, PH1 are connected to P2 R24, R25 and R66 must not be fitted).
SB3,5,7,9 (Default)	ON	Reserved, do not modify
SB2,4,6,8 (Reserved)	OFF	Reserved, do not modify
SB17,18 (X3 crystal)	OFF	X3, C20, C28, R21 and R22 deliver a 32 KHz clock. PC14, PC15 are not connected to P2.
	ON	PC14, PC15 are only connected to P2. Remove only R21, R22
SB1 (B2-RESET)	ON	B2 pushbutton is connected to the NRST pin of the STM32F411VET6 MCU
	OFF	B2 pushbutton is not connected to the NRST pin of the STM32F411VET6 MCU
SB21 (B1-USER)	ON	B1 pushbutton is connected to PA0
	OFF	B1 pushbutton is not connected to PA0
SB13 (NRST)	ON	NRST signal of the CN2 connector is connected to the NRST pin of the STM32F411VET6 MCU
	OFF	NRST signal of the CN2 connector is not connected to the NRST pin of the STM32F411VET6 MCU
SB15 (SWO)	ON	SWO signal of the CN2 connector is connected to PB3
	OFF	SWO signal is not connected
SB10,11 (RX,TX)	OFF	Reserved, do not modify
	ON	Reserved, do not modify
SB12 (STM_RST)	OFF	No incidence on STM32F103C8T6 (ST-LINK/V2) NRST signal
	ON	STM32F103C8T6 (ST-LINK/V2) NRST signal is connected to GND

Table 4. Solder bridges (continued)

Bridge	State ⁽¹⁾	Description
SB19 (BOOT0)	ON	BOOT0 signal of the STM32F411VET6 MCU is held low through a 510 Ω pull-down resistor
	OFF	BOOT0 signal of the STM32F411VET6 MCU is held high through a 10 KΩ pull-up resistor
SB20 (BOOT1)	OFF	The BOOT1 signal of the STM32F411VET6 MCU is held high through a 10 KΩ pull-up resistor
	ON	The BOOT1 signal of the STM32F411VET6 MCU is held low through a 510 Ω pull-down resistor

1. Default SBx state is shown in bold.

4.13 Extension connectors

The male headers P1 and P2 can connect the STM32F411 Discovery board to a standard prototyping/wrapping board. STM32F411VET6 GPIOs are available on these connectors. P1 and P2 can also be probed by an oscilloscope, logical analyzer or voltmeter.

Table 5. MCU pin description versus board function (page 1 of 8)⁽¹⁾

MCU pin		Board function															
Main function	Alternate functions	LQFP100	CS43L22	MP45DT02	L3GD20	LSM303DLHC	Pushbutton	LED	SWD	USB	OSC	Free I/O	Power supply	CN5	CN2	P1	P2
BOOT0	-	94	-	-	-	-	-	-	-	-	-	-	-	-	-	-	21
NRST	-	14	-	-	-	-	RESET	-	-	-	-	-	-	-	-	-	-
PA0-WKUP	TIM2_CH1/TIM2_ETR, TIM5_CH1, USART2_CTS, ADC1_0, WKUP	23	-	-	-	-	USER	-	-	-	-	-	-	-	-	-	-
PA1	TIM2_CH2, TIM5_CH2, USART2_RTS, ADC1_1	24	-	-	-	-	-	-	-	-	-	-	-	-	-	-	-
PA2	TIM2_CH3, TIM5_CH3, TIM9_CH1, USART2_TX, ADC1_2	25	-	-	-	-	-	-	-	-	-	-	-	-	-	14	-
PA3	TIM2_CH4, TIM5_CH4, TIM9_CH2, USART2_RX, ADC1_3	26	-	-	-	-	-	-	-	-	-	-	-	-	-	13	-



Table 5. MCU pin description versus board function (page 2 of 8)⁽¹⁾ (continued)

MCU pin			Board function														
Main function	Alternate functions	LQFP100	CS43L22	MP45DT02	L3GD20	LSM303DLHC	Pushbutton	LED	SWD	USB	OSC	Free I/O	Power supply	CN5	CN2	P1	P2
PA4	SPI1_NSS, SPI3_NSS/I2S3_WS, USART2_CK, ADC1_4	29	LRCK/AIN1X	-	-	-	-	-	-	-	-	-	-	-	-	16	-
PA5	TIM2_CH1/TIM2_ETR, SPI1_SCK, ADC1_5	30	-	-	SCL/SPC	-	-	-	-	-	-	-	-	-	-	15	-
PA6	TIM1_BKIN, TIM3_CH1, SPI1_MISO, ADC1_6	31	-	-	SDO	-	-	-	-	-	-	-	-	-	-	18	-
PA7	TIM1_CH1N, TIM3_CH2, SPI1_MOSI, ADC1_7	32	-	-	SDA/SDI/SDO	-	-	-	-	-	-	-	-	-	-	17	-
PA8	MCO_1, TIM1_CH1, I2C3_SCL, USART1_CK, USB_FS_SOF	67	-	-	-	-	-	-	-	-	-	-	-	-	-	-	43
PA9	TIM1_CH2, I2C3_SMBAL, USART1_TX, USB_FS_VBUS	68	-	-	-	-	-	GREEN	-	VBUS	-	-	-	1	-	-	44
PA10	TIM1_CH3, USART1_RX, USB_FS_ID	69	-	-	-	-	-	-	-	ID	-	-	-	4	-	-	41
PA11	TIM1_CH4, USART1_CTS, USART6_TX, USB_FS_DM	70	-	-	-	-	-	-	-	DM	-	-	-	2	-	-	-
PA12	TIM1_ETR, USART1_RTS, USART6_RX, USB_FS_DP	71	-	-	-	-	-	-	-	DP	-	-	-	3	-	-	-

Table 5. MCU pin description versus board function (page 3 of 8)⁽¹⁾ (continued)

MCU pin			Board function														
Main function	Alternate functions	LQFP100	CS43L22	MP45DT02	L3GD20	LSM303DLHC	Pushbutton	LED	SWD	USB	OSC	Free I/O	Power supply	CN5	CN2	P1	P2
PA13	JTMS-SWDIO	72	-	-	-	-	-	-	SWDIO	-	-	-	-	-	4	-	42
PA14	JTCK-SWCLK, I2S3ext_WS	76	-	-	-	-	-	-	SWCLK	-	-	-	-	-	2	-	39
PA15	JTDI, TIM2_CH1/TIM2_ETR, SPI1_NSS, SPI3_NSS/I2S3_WS	77	-	-	-	-	-	-	-	-	-	-	-	-	-	-	40
PB0	TIM1_CH2N, TIM3_CH3, ADC1_8	35	-	-	-	-	-	-	-	-	-	-	-	-	-	22	-
PB1	TIM1_CH3N, TIM3_CH4, ADC1_9	36	-	-	-	-	-	-	-	-	-	-	-	-	-	21	-
PB2		37	-	-	-	-	-	-	-	-	-	-	-	-	-	24	-
PB3	JTDO-SWO, TIM2_CH2, SPI1_SCK, SPI3_SCK/I2S3_CK, I2C2_SDA	89	-	-	-	-	-	-	SWO	-	-	-	-	-	6	-	28
PB4	JTRST, TIM3_CH1, SPI1_MISO, SPI3_MISO, I2S3ext_SD, I2C3_SDA	90	-	-	-	-	-	-	-	-	-	-	-	-	-	-	25
PB5	TIM3_CH2, I2C1_SMBAL, SPI1_MOSI, SPI3_MOSI/I2S3_SD	91	-	-	-	-	-	-	-	-	-	-	-	-	-	-	26
PB6	TIM4_CH1, I2C1_SCL, USART1_TX, USB_FS_INT	92	SCL	-	-	SCL	-	-	-	-	-	-	-	-	-	-	23
PB7	TIM4_CH2, I2C1_SDA, USART1_RX	93	-	-	-	-	-	-	-	-	-	-	-	-	-	-	24

Table 5. MCU pin description versus board function (page 4 of 8)⁽¹⁾ (continued)

MCU pin			Board function														
Main function	Alternate functions	LQFP100	CS43L22	MP45DT02	L3GD20	LSM303DLHC	Pushbutton	LED	SWD	USB	OSC	Free I/O	Power supply	CN5	CN2	P1	P2
PB8	TIM4_CH3, TIM10_CH1, I2C1_SCL, USB_FS_SCL, SDIO_D4	95	-	-	-	-	-	-	-	-	-	-	-	-	-	-	19
PB9	TIM4_CH4, TIM11_CH1, I2C1_SDA, SPI2_NSS/I2S2_WS, USB_FS_SDA, SDIO_D5	96	SDA	-	-	SDA	-	-	-	-	-	-	-	-	-	-	20
PB10	TIM2_CH3, I2C2_SCL, SPI2_SCK/I2S2_CK	47	-	-	-	-	-	-	-	-	-	-	-	-	-	34	-
VCAP1	-	48	-	-	-	-	-	-	-	-	-	-	-	-	-	35	-
PB12	TIM1_BKIN, I2C2_SMBAL, SPI2_NSS/I2S2_WS, I2S2ext_WS	51	-	-	-	-	-	-	-	-	-	-	-	-	-	36	-
PB13	TIM1_CH1N, SPI2_SCK/I2S2_CK, I2S2ext_CK	52	-	-	-	-	-	-	-	-	-	-	-	-	-	37	-
PB14	TIM1_CH2N, SPI2_MISO, I2S2ext_SD	53	-	-	-	-	-	-	-	-	-	-	-	-	-	38	-
PB15	RTC_50Hz, TIM1_CH3N, SPI2_MOSI/I2S2_SD, I2S2ext_MISO	54	-	-	-	-	-	-	-	-	-	-	-	-	-	39	-
PC0	ADC1_10	15	-	-	-	-	-	-	-	PowerOn	-	-	-	-	-	8	-
PC1	ADC1_11	16	-	-	-	-	-	-	-	-	-	-	-	-	-	7	-
PC2	SPI2_MISO, I2S2ext_SD, ADC1_12	17	-	-	-	-	-	-	-	-	-	-	-	-	-	10	-

Table 5. MCU pin description versus board function (page 5 of 8)⁽¹⁾ (continued)

MCU pin			Board function														
Main function	Alternate functions	LQFP100	CS43L22	MP45DT02	L3GD20	LSM303DLHC	Pushbutton	LED	SWD	USB	OSC	Free I/O	Power supply	CN5	CN2	P1	P2
PC3	SPI2_MOSI/I2S2_SD, ADC1_13	18	AIN4x	PDM_OUT	-	-	-	-	-	-	-	-	-	-	-	9	-
PC4	ADC1_14	33	-	-	-	-	-	-	-	-	-	-	-	-	-	20	-
PC5	ADC1_15	34	-	-	-	-	-	-	-	-	-	-	-	-	-	19	-
PC6	TIM3_CH1, I2S2_MCK, USART6_TX, SDIO_D6	63	-	-	-	-	-	-	-	-	-	-	-	-	-	-	47
PC7	TIM3_CH2, I2S3_MCK, USART6_RX, SDIO_D7	64	MCLK	-	-	-	-	-	-	-	-	-	-	-	-	-	48
PC8	MCO_CPUCK, TIM3_CH3, USART6_CK, SDIO_D0	65	-	-	-	-	-	-	-	-	-	-	-	-	-	-	45
PC9	MCO_2, TIM3_CH4, I2C3_SDA, I2S2_CKIN, SDIO_D1	66	-	-	-	-	-	-	-	-	-	-	-	-	-	-	46
PC10	I2S3ext_CK, SPI3_SCK/I2S3_CK, SDIO_D2	78	SCLK	-	-	-	-	-	-	-	-	-	-	-	-	-	37
PC11	I2S3ext_SD, SPI3_MISO, SDIO_D3	79	-	-	-	-	-	-	-	-	-	-	-	-	-	-	38
PC12	I2S3ext_MISO, SPI3_MOSI/I2S3_SD, SDIO_CK	80	SDIN	-	-	-	-	-	-	-	-	-	-	-	-	-	35
PC13	TAMP_1	7	-	-	-	-	-	-	-	-	-	-	-	-	-	-	12
PC14	OSC32_IN	8	-	-	-	-	-	-	-	-	OSC32_IN	-	-	-	-	-	9
PC15	OSC32_OUT	9	-	-	-	-	-	-	-	-	OSC32_OUT	-	-	-	-	-	10
PD0	-	81	-	-	-	-	-	-	-	-	-	-	-	-	-	-	36

Table 5. MCU pin description versus board function (page 6 of 8)⁽¹⁾ (continued)

MCU pin			Board function														
Main function	Alternate functions	LQFP100	CS43L22	MP45DT02	L3GD20	LSM303DLHC	Pushbutton	LED	SWD	USB	OSC	Free I/O	Power supply	CN5	CN2	P1	P2
PD1	-	82	-	-	-	-	-	-	-	-	-	-	-	-	-	-	33
PD2	-	83	-	-	-	-	-	-	-	-	-	-	-	-	-	-	34
PD3	-	84	-	-	-	-	-	-	-	-	-	-	-	-	-	-	31
PD4	-	85	RESET	-	-	-	-	-	-	-	-	-	-	-	-	-	32
PD5	-	86	-	-	-	-	-	RED	-	-	-	-	-	-	-	-	-
PD6	-	87	-	-	-	-	-	-	-	-	-	-	-	-	-	-	-
PD7	-	88	-	-	-	-	-	-	-	-	-	-	-	-	-	-	-
PD8	-	55	-	-	-	-	-	-	-	-	-	-	-	-	-	40	-
PD9	-	56	-	-	-	-	-	-	-	-	-	-	-	-	-	41	-
PD10	-	57	-	-	-	-	-	-	-	-	-	-	-	-	-	42	-
PD11	-	58	-	-	-	-	-	-	-	-	-	-	-	-	-	43	-
PD12	TIM4_CH1	59	-	-	-	-	-	GREEN	-	-	-	-	-	-	-	44	-
PD13	TIM4_CH2	60	-	-	-	-	-	ORANGE	-	-	-	-	-	-	-	45	-
PD14	TIM4_CH3	61	-	-	-	-	-	RED	-	-	-	-	-	-	-	46	-
PD15	TIM4_CH4	62	-	-	-	-	-	BLUE	-	-	-	-	-	-	-	47	-
PE0	TIM4_ETR	97	-	-	INT1	-	-	-	-	-	-	-	-	-	-	-	17
PE1	-	98	-	-	INT2	-	-	-	-	-	-	-	-	-	-	-	18
PE2	-	1	-	-	-	DRDY	-	-	-	-	-	-	-	-	-	-	15

Table 5. MCU pin description versus board function (page 7 of 8)⁽¹⁾ (continued)

MCU pin			Board function														
Main function	Alternate functions	LQFP100	CS43L22	MP45DT02	L3GD20	LSM303DLHC	Pushbutton	LED	SWD	USB	OSC	Free I/O	Power supply	CN5	CN2	P1	P2
PE3	-	2	-	-	CS_I2C/SPI	-	-	-	-	-	-	-	-	-	-	-	16
PE4	-	3	-	-	-	-	-	-	-	-	-	-	-	-	-	-	13
PE5	-	4	-	-	-	-	-	-	-	-	-	-	-	-	-	-	14
PE6	-	5	-	-	-	-	-	-	-	-	-	-	-	-	-	-	11
PE7	-	38	-	-	-	-	-	-	-	-	-	-	-	-	-	25	-
PE8	-	39	-	-	-	-	-	-	-	-	-	-	-	-	-	-	26
PE9	-	40	-	-	-	-	-	-	-	-	-	-	-	-	-	-	27
PE10	-	41	-	-	-	-	-	-	-	-	-	-	-	-	-	-	28
PE11	TIM1_CH2, SPI4_NSS	42	-	-	-	-	-	-	-	-	-	-	-	-	-	-	29
PE12	TIM1_CH3N, SPI4_SCK	43	-	-	-	-	-	-	-	-	-	-	-	-	-	-	30
PE13	TIM1_CH3, SPI4_MISO	44	-	-	-	-	-	-	-	-	-	-	-	-	-	-	31
PE14	TIM1_CH4, SPI4_MOSI	45	-	-	-	-	-	-	-	-	-	-	-	-	-	-	32
PE15	TIM1_BKIN	46	-	-	-	-	-	-	-	-	-	-	-	-	-	-	33
PH0	OSC_IN	12	-	-	-	-	-	-	-	-	OSC_IN	-	-	-	-	-	7
PH1	OSC_OUT	13	-	-	-	-	-	-	-	-	OSC_OUT	-	-	-	-	-	8
-	-	-	-	-	-	-	-	-	-	-	-	-	5 V	-	-	-	3
-	-	-	-	-	-	-	-	-	-	-	-	-	5 V	-	-	-	4
-	-	-	-	-	-	-	-	-	-	-	-	-	3 V	-	-	-	5
-	-	-	-	-	-	-	-	-	-	-	-	-	3 V	-	-	-	6
-	-	-	-	-	-	-	-	-	-	-	-	-	VDD	-	-	3	22

Table 5. MCU pin description versus board function (page 8 of 8)⁽¹⁾ (continued)

MCU pin		Board function															
Main function	Alternate functions	LQFP100	CS43L22	MP45DT02	L3GD20	LSM303DLHC	Pushbutton	LED	SWD	USB	OSC	Free I/O	Power supply	CN5	CN2	P1	P2
-	-	-	-	-	-	-	-	-	-	-	-	-	VDD	-	-	4	-
-	-	-	-	-	-	-	-	-	GND	GND	-	-	GND	5	3	1	-
-	-	-	-	-	-	-	-	-	-	-	-	-	GND	-	-	2	-
-	-	-	-	-	-	-	-	-	-	-	-	-	GND	-	-	5	-
-	-	-	-	-	-	-	-	-	-	-	-	-	GND	-	-	23	-
-	-	-	-	-	-	-	-	-	-	-	-	-	GND	-	-	49	-
-	-	-	-	-	-	-	-	-	-	-	-	-	GND	-	-	50	-

1. The default configuration for the functions used on the boards, is shown in grey color.



6

Electrical schematics

Figure 9. STM32F411 Discovery board

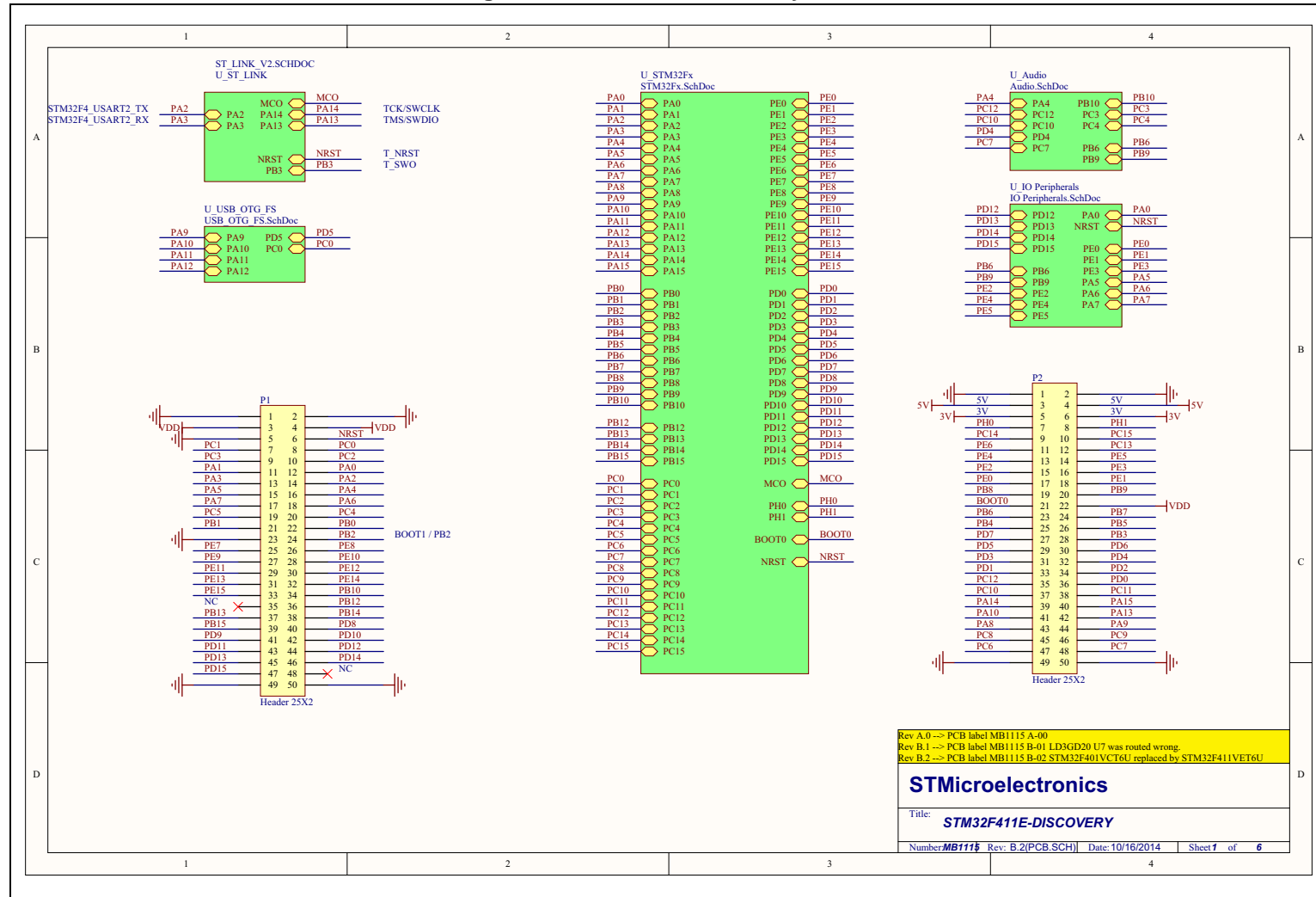

Rev A.0 --> PCB label MB1115 A-00
 Rev B.1 --> PCB label MB1115 B-01 LD3GD20 U7 was routed wrong.
 Rev B.2 --> PCB label MB1115 B-02 STM32F401VC76U replaced by STM32F411VET6U

STMicroelectronics			
Title: STM32F411E-DISCOVERY			
Number	Rev:	Date:	Sheet
MB1115	B.2(PCB.SCH)	10/16/2014	7 of 6

Figure 12. Audio

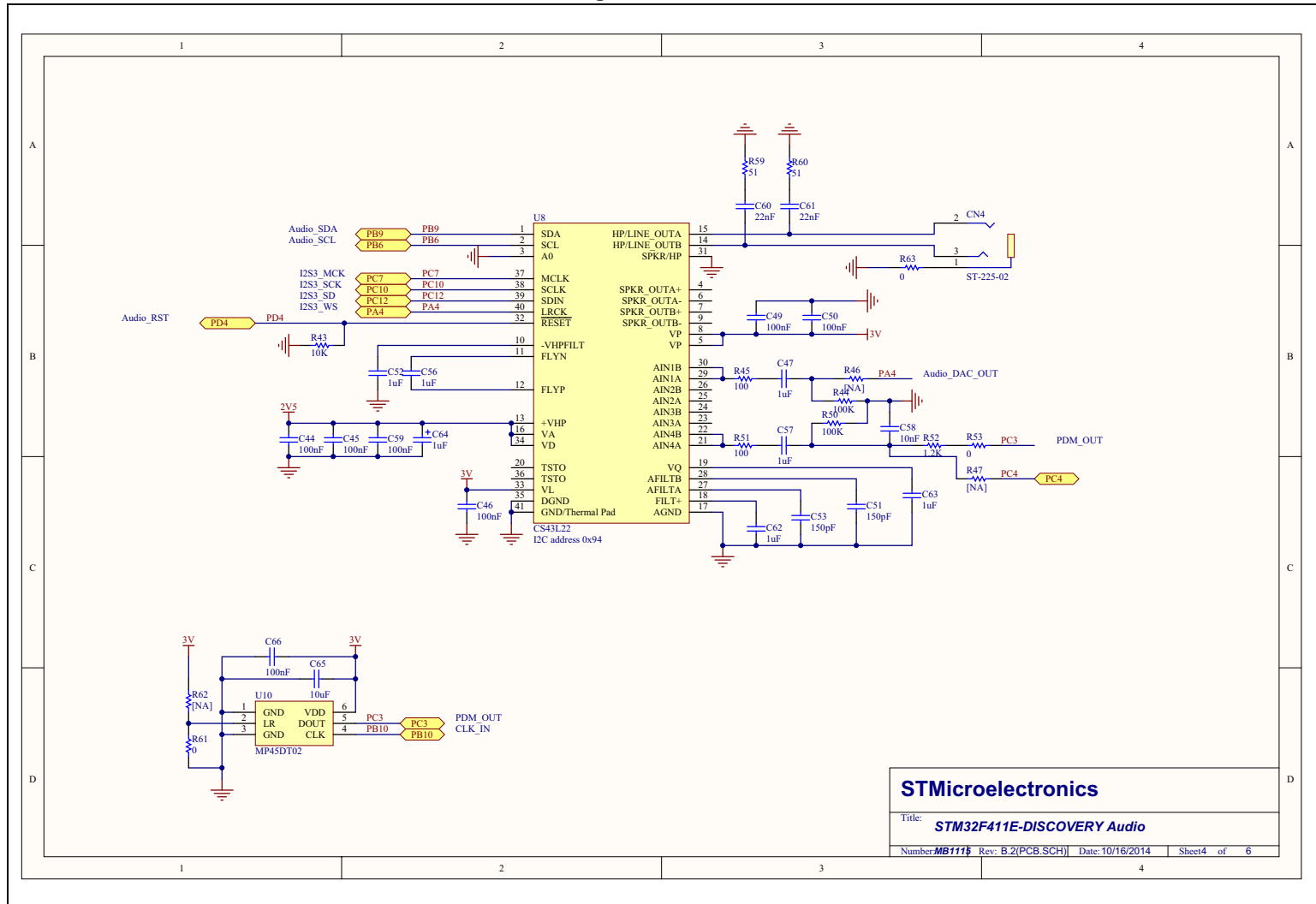

STMicroelectronics

Title: **STM32F411E-Discovery Audio**

Number: **MB1111** Rev: B.2(PCB.SCH) Date: 10/16/2014 Sheet 4 of 6

Figure 14. Peripherals

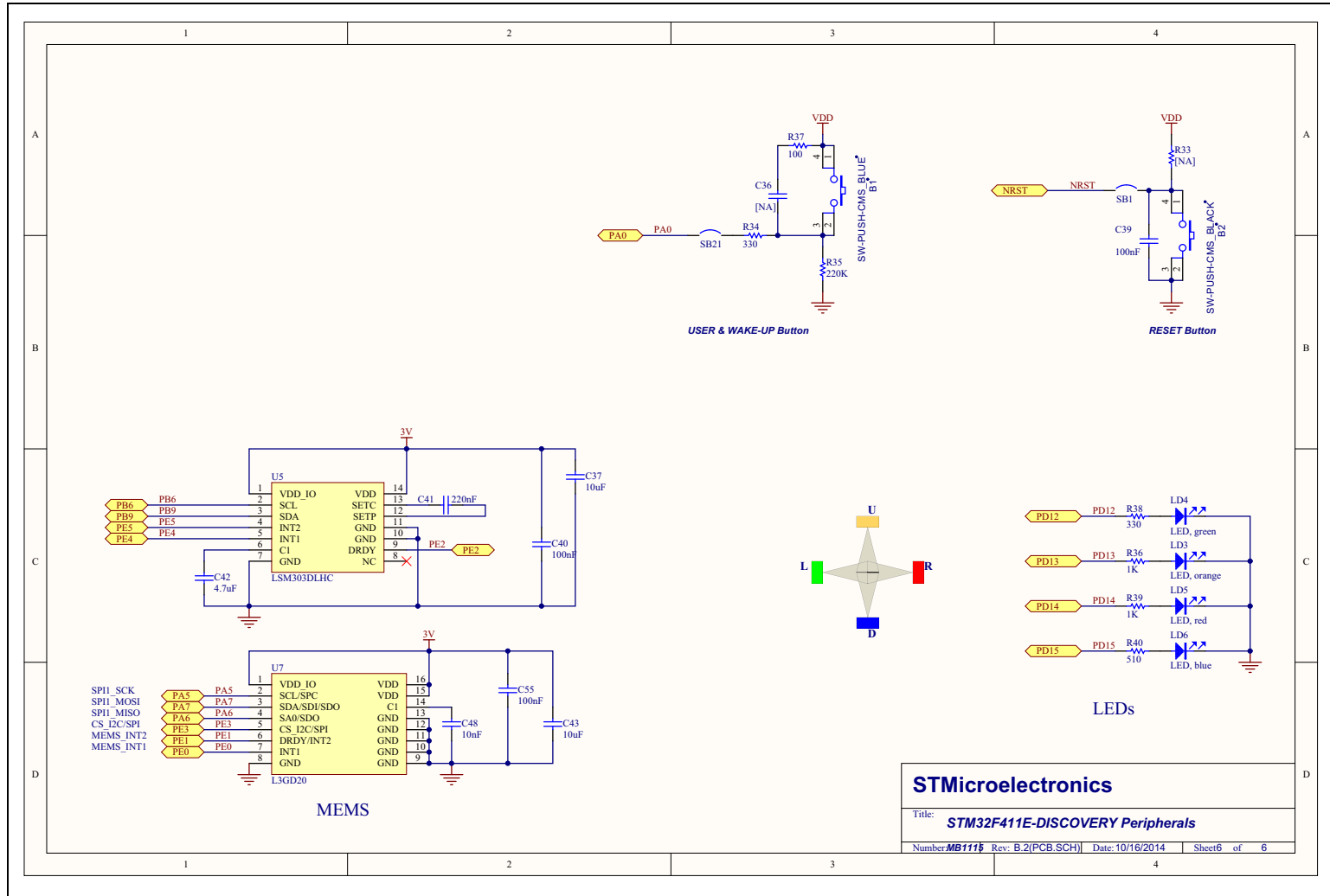

7 Revision history

Table 6. Document revision history

Date	Revision	Changes
16-Dec-2014	1	Initial release.

IMPORTANT NOTICE – PLEASE READ CAREFULLY

STMicroelectronics NV and its subsidiaries ("ST") reserve the right to make changes, corrections, enhancements, modifications, and improvements to ST products and/or to this document at any time without notice. Purchasers should obtain the latest relevant information on ST products before placing orders. ST products are sold pursuant to ST's terms and conditions of sale in place at the time of order acknowledgement.

Purchasers are solely responsible for the choice, selection, and use of ST products and ST assumes no liability for application assistance or the design of Purchasers' products.

No license, express or implied, to any intellectual property right is granted by ST herein.

Resale of ST products with provisions different from the information set forth herein shall void any warranty granted by ST for such product.

ST and the ST logo are trademarks of ST. All other product or service names are the property of their respective owners.

Information in this document supersedes and replaces information previously supplied in any prior versions of this document.

© 2014 STMicroelectronics – All rights reserved