

REV.	ECON. NO.	REVISE. NO.	REVISED	APPD.
版次	CON. 编号	次数	修订者	核准
R1	Drawing			

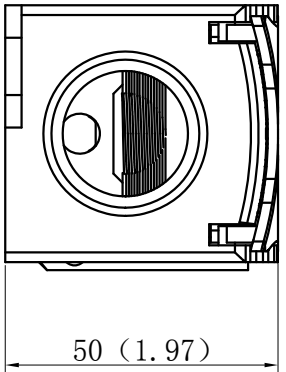
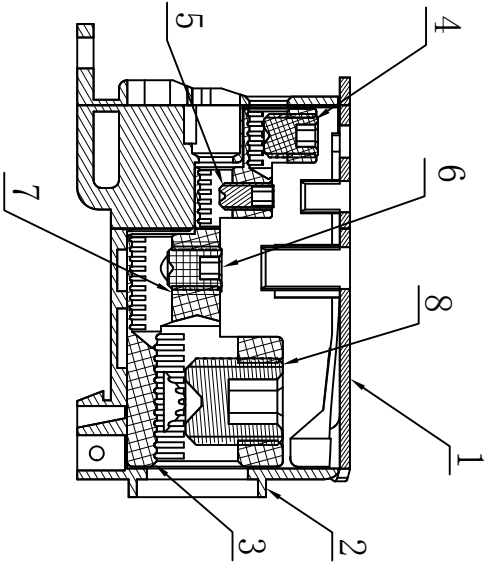
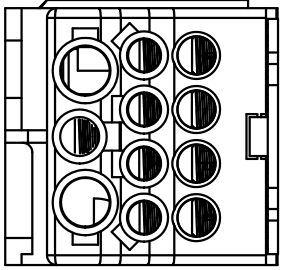
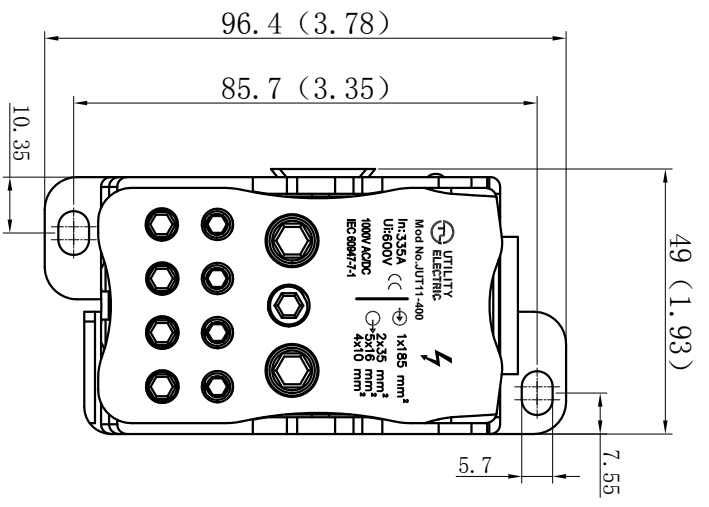
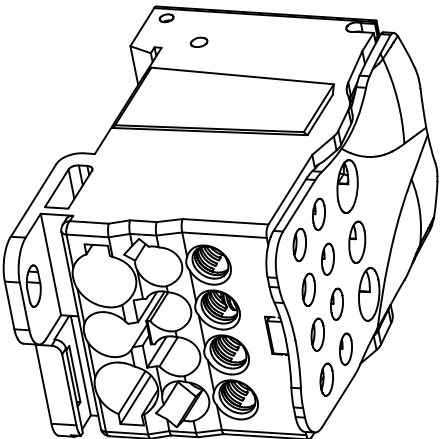

**SPECIFICATIONS**

**1. Material:**

- ①Cover: PC UL94-V0
- ②Body: PA66 UL94-V0
- ③Block: COPPER (NI PLATED)
- ④Screw: STEEL (ZINC PLATED)
- ⑤Screw: STEEL (ZINC PLATED)
- ⑥Screw: STEEL (ZINC PLATED)
- ⑦Screw: STEEL (ZINC PLATED)
- ⑧Screw: STEEL (ZINC PLATED)

**2. Electrical:**

- (1)Voltage rating/Current rating: 690V / 400A.
- (2)Insulation resistance: DC1000V 1000 MΩMin.
- (3>Contact resistance: 20 mΩMax.

**3. Mechanical:**

- (1)Torque force: 2.7N·m Max./4.5N·m Max./6.5N·m Max.
- (2)Stripping Length: 18~20mm.
- (3)Connection Capacity: 2.5~16mm<sup>2</sup>/6~35mm<sup>2</sup>/95~185mm<sup>2</sup>.
- (4)Operating temperature: -45° C to +105° C.
- 4. Standard: IEC 60947-7-1;
- 5. Certification: CE RoHS;
- 6. Ingress Protection: IP20 Fingerproofed;



**ZHEJIANG UTILITY ELECTRICAL CO., LTD**  
**浙江尤提乐电气有限公司**

TYPE NO.	JUT11-400	TITLE	名称: Customer Drawing
APPD.		DWG. NO.:	C-JM1105-0
CHKD.		SCALE:	FULL
DR.	Jammy. ling	PAGE:	1/1
MATL.		REV.:	R1